

100 W motor control power board based on STIPN2M50T-H SLLIMM™ nano IPM MOSFET

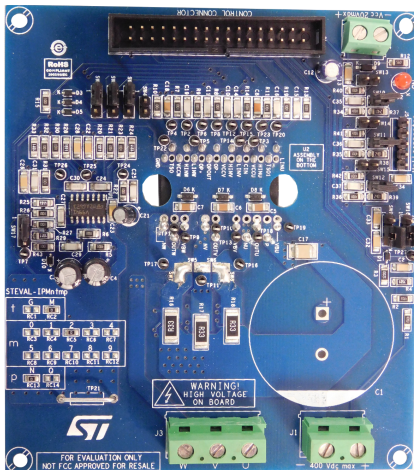

Features

- Input voltage: from 125 to 400 V_{DC}
- Nominal power: up to 100 W
- Nominal current: up to 0.6 A_{rms}
- Input auxiliary voltage: up to 20 V_{DC}
- Single- or three-shunt resistors for current sensing (with sensing network)
- Three options for current sensing: dedicated external op-amps, internal SLLIMM-nano op-amp (single) or via MCU
- Overcurrent hardware protection
- IPM temperature monitoring and protection
- Hall sensor or encoder input
- Intelligent power module:
 - SLLIMM-nano IPM MOSFET-based (STIPN2M50T-H – full molded package)
- Motor control connector (32 pins) interfacing with ST MCU boards
- Universal design for further evaluation with bread board and testing pins
- Very compact size
- RoHS compliant

Description

The STEVAL-IPMnM2N is a compact motor drive power board based on SLLIMM™-nano (small low-loss intelligent molded module) MOSFET-based product (STIPN2M50T-H). It provides an affordable and easy-to-use solution for driving high power motors in a wide range of applications such as power white goods, air conditioning, compressors, power fans and 3-phase inverters for motor drives in general.

The IPM itself consists of short-circuit rugged MOSFETs and a wide range of features like undervoltage lockout, smart shutdown, internal temperature sensor and NTC, overcurrent protection and internal op-amp.

The main characteristics of this evaluation board are small size, minimal BOM and high efficiency. It features an interface circuit (BUS and V_{CC} connectors), bootstrap capacitors, snubber capacitor, hardware short-circuit protection, fault event signal and temperature monitoring. It is designed to work in single- or three-shunt configuration and with triple current sensing options: three dedicated on-board op-amps, op-amps embedded on MCU or single internal IPM op-amp. The Hall/Encoder part completes the circuit.

The system is designed to achieve accurate and fast conditioning of current feedback to satisfy the typical requirements for field oriented control (FOC).

The STEVAL-IPMnM2N is compatible with ST's control board based on STM32, providing a complete platform for motor control.

Product summary	
Compact motor drive power board	STEVAL-IPMnM2N
SLLIMM-nano small low-loss intelligent molded module IPM, 3-phase inverter, 2 A, 1.7 Ohm max., 500 V MOSFET	STIPN2M50T-H

1 Schematic diagrams

Figure 1. STEVAL-IPMnM2N circuit schematic (1 of 5)

Figure 2. STEVAL-IPMnM2N circuit schematic (2 of 5)

Figure 3. STEVAL-IPMnM2N circuit schematic (3 of 5)

Figure 4. STEVAL-IPMnM2N circuit schematic (4 of 5)

Figure 5. STEVAL-IPMnM2N circuit schematic (5 of 5)

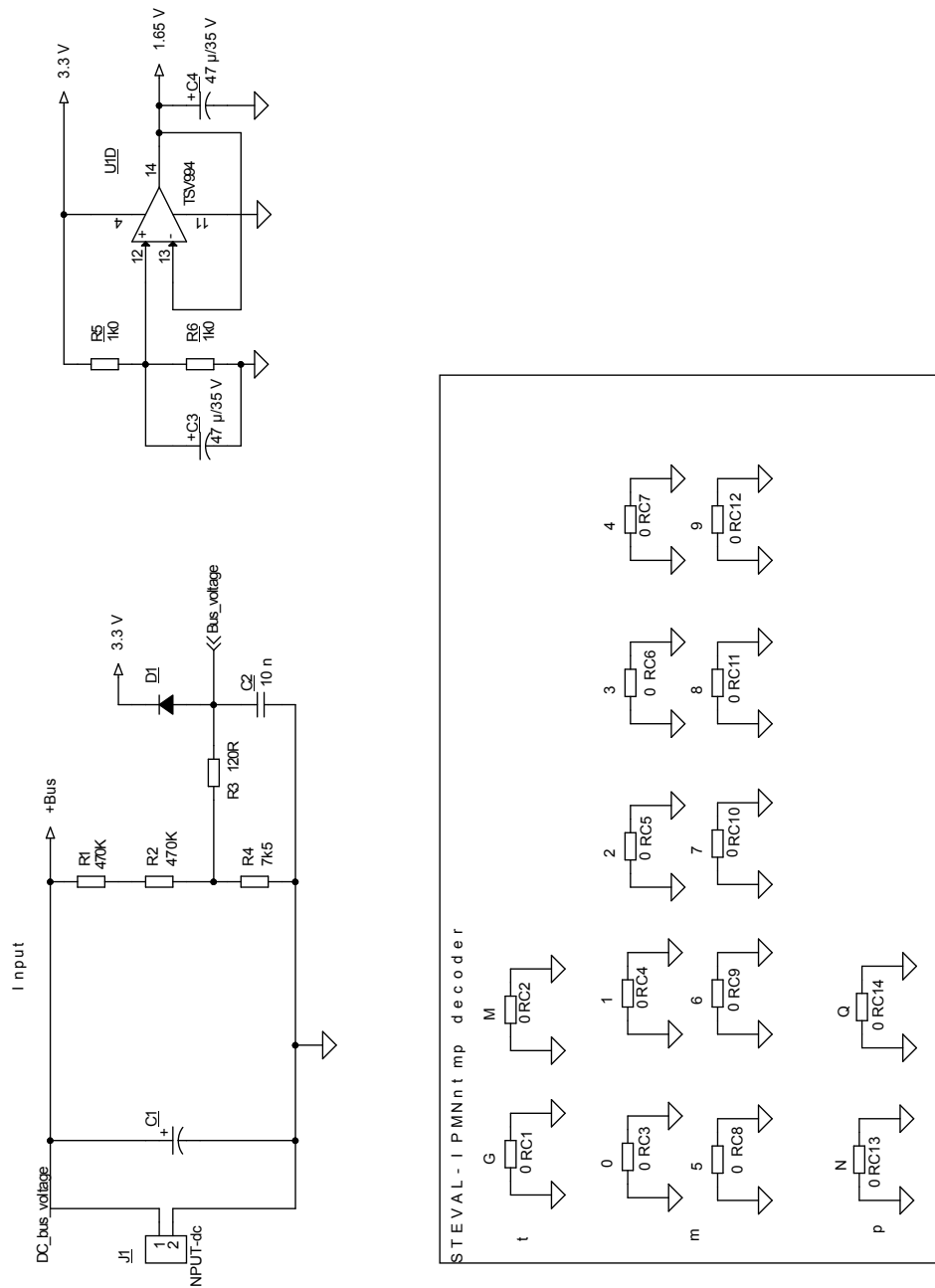
Revision history

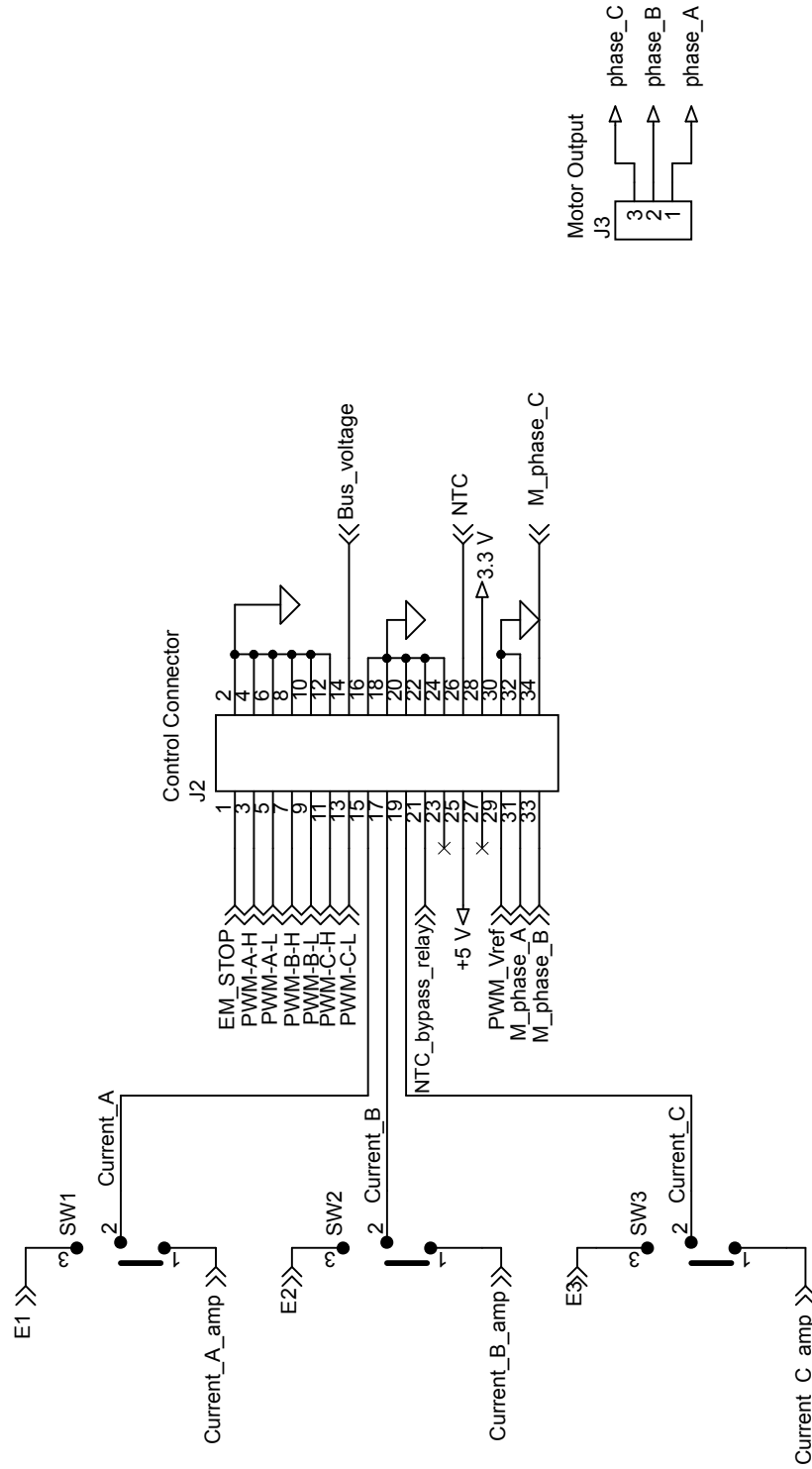
Table 1. Document revision history

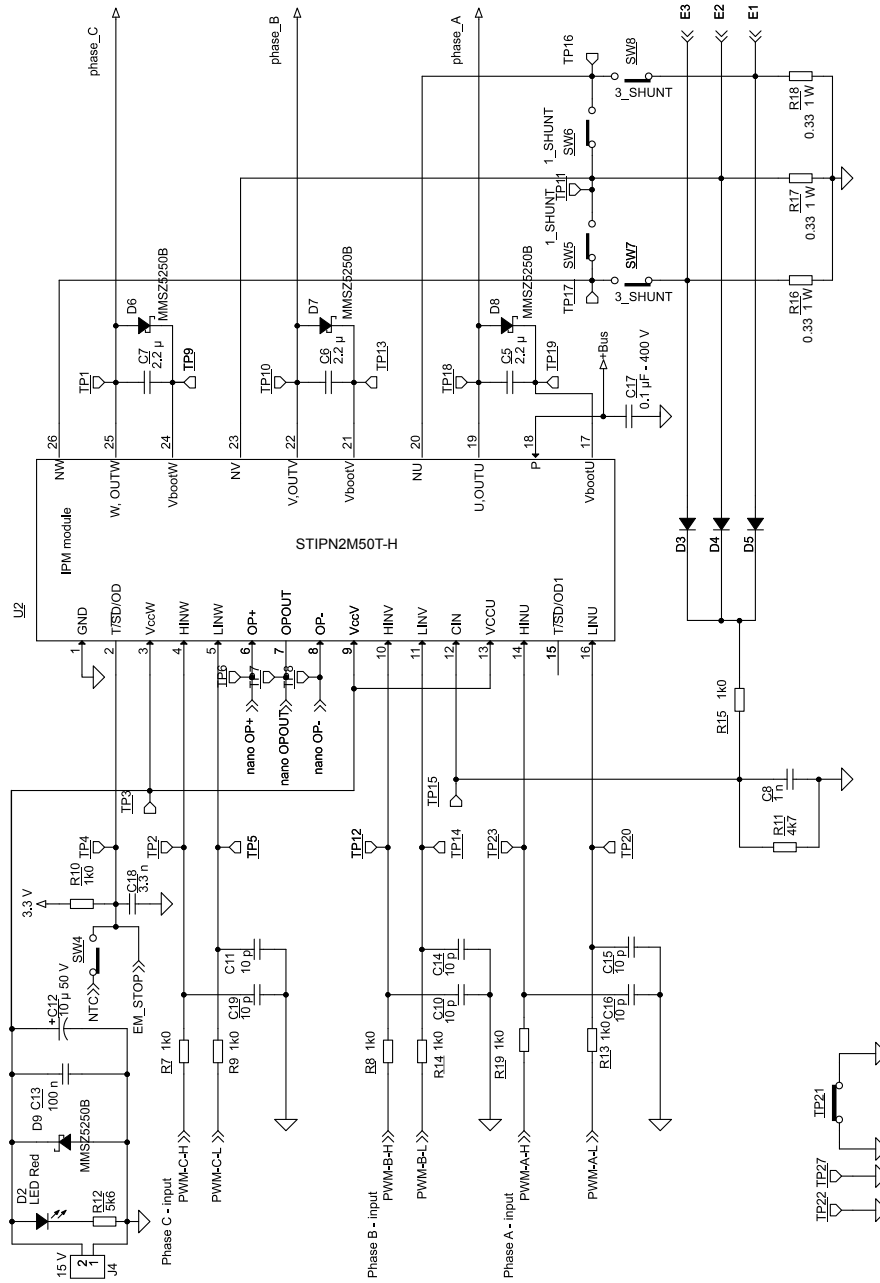
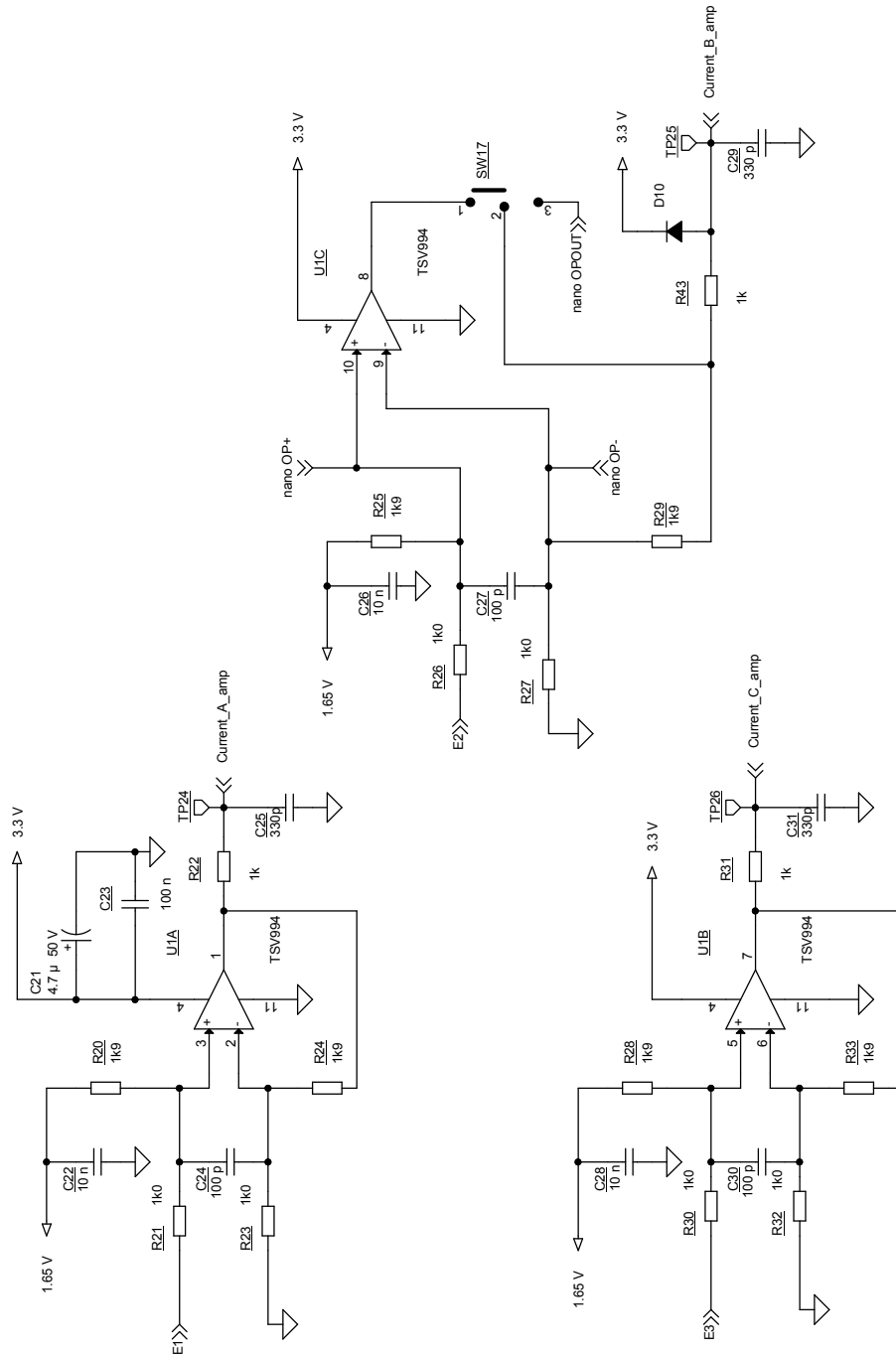
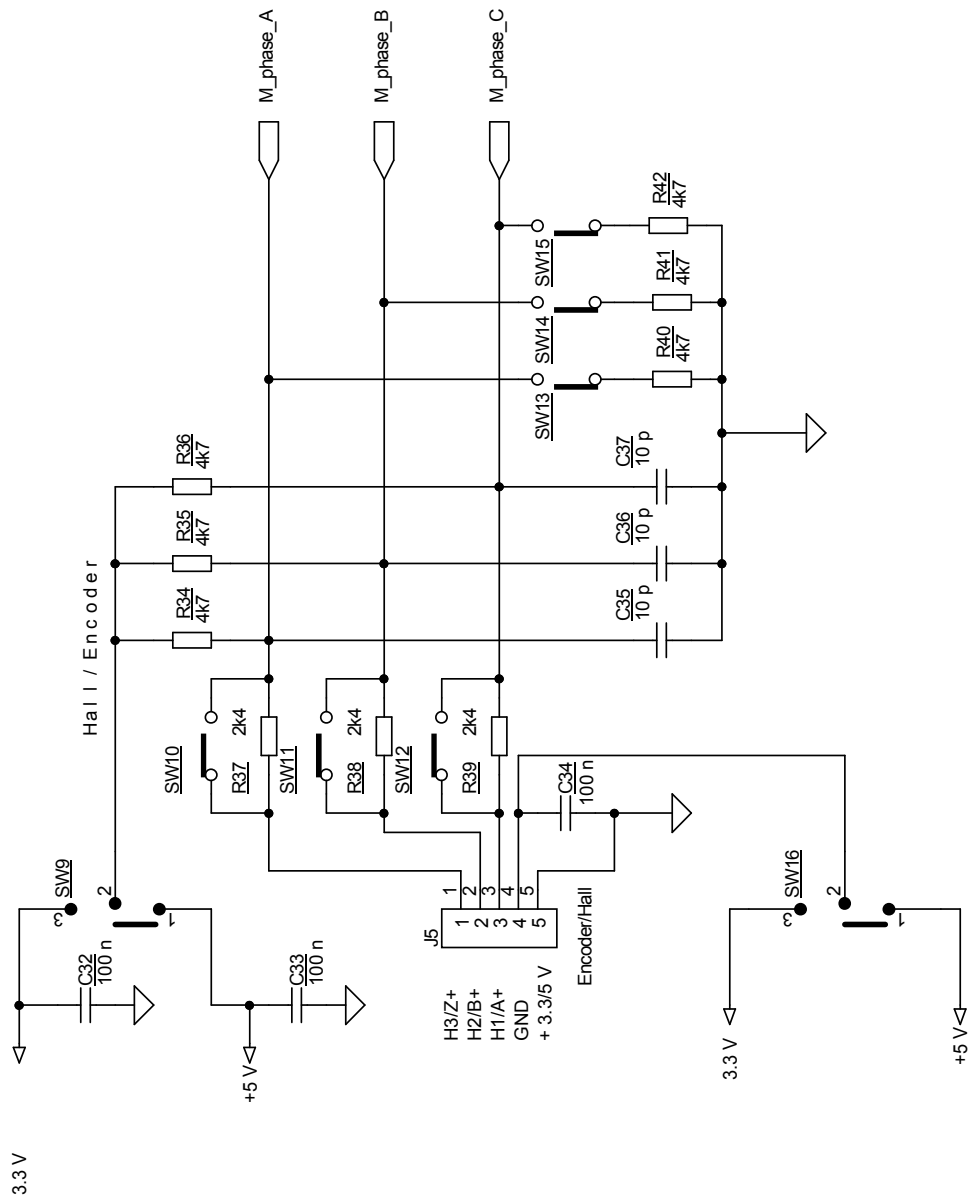
Date	Version	Changes
05-Sep-2017	1	Initial release.
07-May-2018	2	Updated title in cover page Updated Section • Features Updated Section • Description