



STEVAL-ISA042V2

1.5 A / 3.3 V step-down DC-DC converter demonstration board
based on the ST1S03

Data brief

Features

- Adjustable current-mode PWM step-down DC-DC converter
- Output voltage, V_{out} : 3.3 V
- Output current, I_{out} : 1.5 A
- Internal compensation to eliminate additional components
- Pulse skipping for I_{out} lower than 15 mA, to maintain the regulation with light loads
- RoHS compliant

Description

The STEVAL-ISA042V2 demonstration board is a step-down DC-DC converter optimized for powering the low-voltage digital core in HDD applications and, more generally, replacing the high-current linear solution when the power dissipation may cause excessive heating of the application environment. It provides up to 1.5 A over an input voltage range of 3 V to 16 V.

A high switching frequency (1.5 MHz) allows the use of tiny surface-mounted components, as well as the use of a resistor divider to set the output voltage value. Only an inductor, a Schottky diode, and two capacitors are required. In addition, a low output ripple is guaranteed by the current-mode PWM topology and by the use of low ESR SMD ceramic capacitors. The device is thermal protected and current limited to prevent damage due to accidental short-circuits.

It uses the ST1S03 device.

The ST1S03 is available in a DFN6 (3x3mm) package.



1 Circuit schematic

Figure 1. STEVAL-ISA042V2 demonstration board schematic

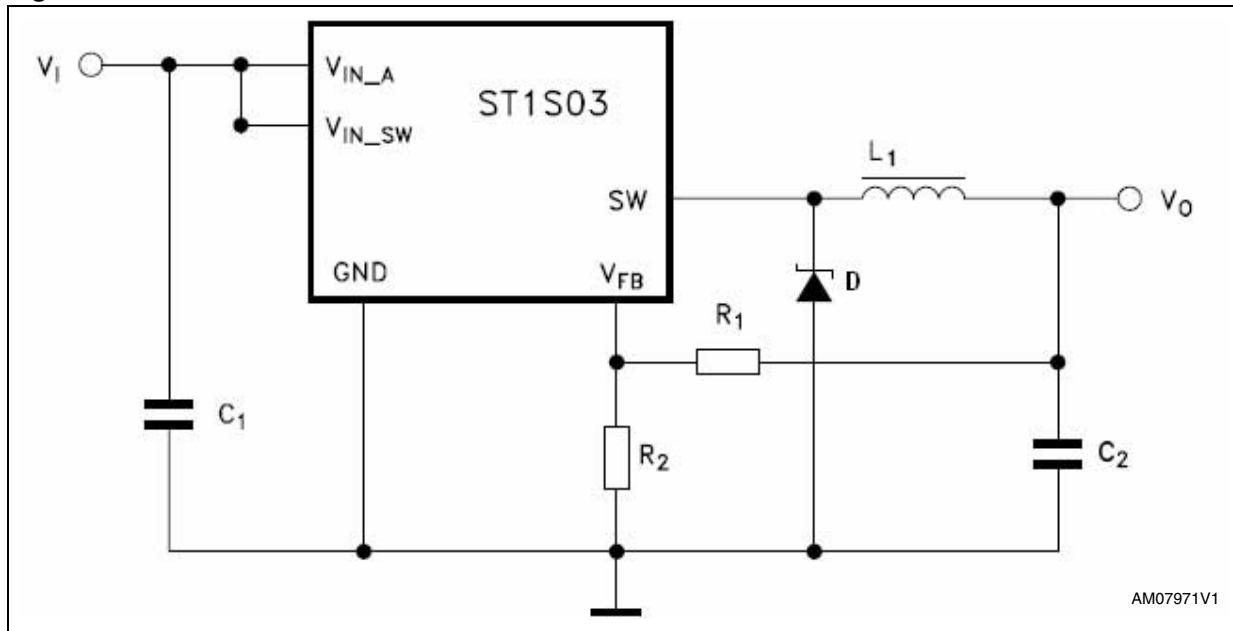

2 Revision history

Table 1. Document revision history

Date	Revision	Changes
28-Sep-2010	1	Initial release.