



STEVAL-ISA055V2

0.7 A / 3.3 V synchronous buck converter
with enable function based on the ST1S12XX

Data Brief

Features

- Step-down current mode PWM (1.7 MHz) DC-DC converter
- Fixed output voltage 3.3 V
- 0.7 A output current capability
- 3% DC output voltage tolerance
- Synchronous rectification
- Enable function
- Internal soft-start
- Typical efficiency: > 90%
- Non switching quiescent current: max 600 μ A over temperature range
- $R_{DS(on)}$ typ. 250 m Ω and 400 m Ω
- Uses tiny capacitors and inductors

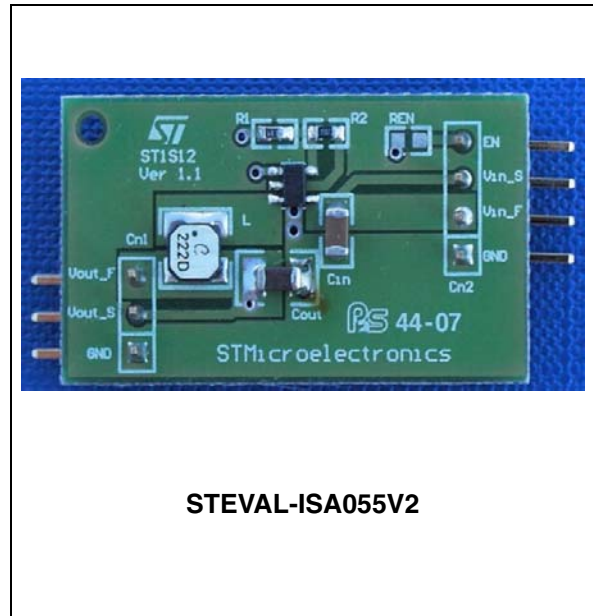

Description

This demonstration board is based on the ST1S12 family of synchronous step-down DC-DC converters optimized for powering low-voltage digital cores in HDD (hard disk drive) applications, and is generally used to replace high-current linear solutions when power dissipation may cause high heating of the application environment.

It provides up to 0.7 A over an input voltage range of 2.5 V to 5.5 V. A high switching frequency of 1.7 MHz allows the use of tiny surface-mount components. A resistor divider to set the output voltage value, an inductor, and two capacitors are required for the adjustable version, while only an inductor and 2 capacitors are needed for the 1.2 V and 1.8 V fixed version.

A low output ripple is guaranteed by the current mode PWM topology and by the use of low ESR surface-mount ceramic capacitors.

The ST1S12 device is thermal protected and current limited to prevent damage due to accidental short-circuit. This family of products is available in the TSOT23-5L package.

1 Schematic diagram

Figure 1. ST1S12 circuit schematic diagram

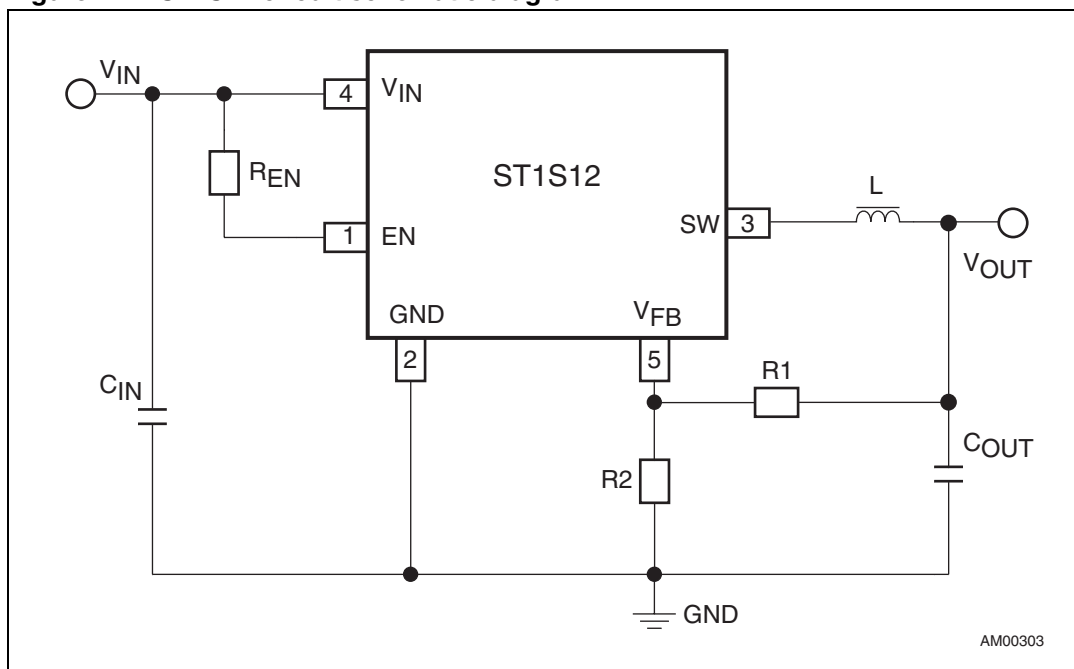

2 Revision history

Table 1. Document revision history

Date	Revision	Changes
18-Sep-2008	1	Initial release.