

High efficiency synchronous step-up regulator based on the L6926

Data brief

Features

- 2 V to 5.5 V battery input range
- High efficiency: up to 95%
- Extremely low quiescent current
- 1 μ A max. shutdown supply current
- 800 mA max. output current
- Adjustable output voltage from 0.6 V
- Low dropout operation: up to 100% duty cycle
- $\pm 1\%$ output voltage accuracy
- 600 MHz switching frequency externally synchronizable up to 1.4 MHz
- Short-circuit protection
- RoHS compliant

Description

The STEVAL-ISA078V1 demonstration board is a high efficiency monolithic synchronous step-down regulator capable of delivering up to 800 mA of continuous output current and of regulating the output voltage from 0.6 V up to V_{IN} thanks to the 100% duty cycle operation capability.

The input voltage ranges from 2 V to 5.5 V.

The control loop architecture is based on a constant frequency peak current mode, while high efficiency at light loads is achieved by a low consumption functionality.

The very low quiescent current (25 μ A) and shutdown current (0.2 μ A) means that the device is very suitable for supplying battery-powered equipment like PDAs, hand-held terminals, DSCs (digital still cameras) and cellular phones.

The switching frequency is internally set at 600 kHz, but the device can be externally synchronized up to 1.4 MHz. An internal reference voltage of 0.6 V (typ.) allows the device to regulate a minimum output voltage of the same low value.

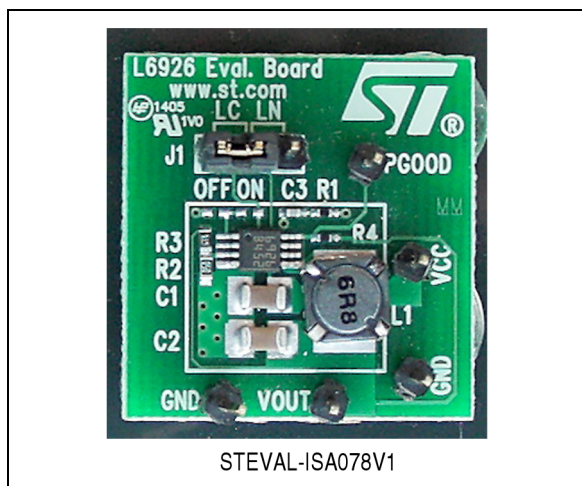

The low MOSFET $R_{DS(on)}$ ensures high efficiency at high output current.

Additional beneficial features are: hysteretic UVLO, OVP, constant current short-circuit protection, Power Good and thermal shutdown.

The MSOP8 package allows significant space savings on the board.

1 Circuit schematic

Figure 1. Circuit schematic

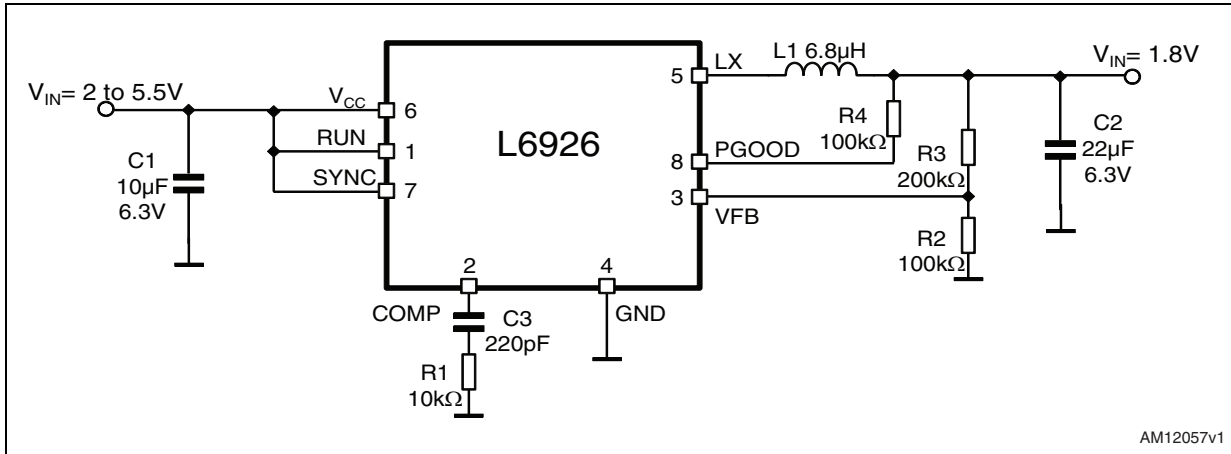

2 Revision history

Table 1. Document revision history

Date	Revision	Changes
20-Mar-2012	1	Initial release.