

## 12 V, 15 W (20 W peak) isolated flyback converter based on the VIPER38LE

Data brief



### Features

- Universal input mains range: 90 – 265 V<sub>AC</sub> frequency: 50 - 60 Hz
- Output voltage/current: 12 V/1.25 A (1.65 A peak)
- Very compact size
- Standby mains consumption: lower than 30 mW at 230 V<sub>AC</sub>
- Minimum active mode efficiency: 81.55%
- Minimum active mode at 10% load efficiency: 71.55%
- EMI: in accordance with EN55022-Class-B
- RoHS compliant

### Description

The STEVAL-ISA153V1 product evaluation board implements a 12 V/1.25 A, 15 W (20 W peak) isolated flyback wide-range mains developed for general-purpose applications.

The core of the application is the VIPER38LE, the latest offline converter from the VIPerPlus family. The device is a high-voltage converter that smartly integrates an 800 V rugged power MOSFET with PWM current-mode control. The device features an adjustable extra power timer (EPT) that enables the IC to sustain overload conditions for a few seconds.

The main characteristics of the evaluation board are its small size and minimal BOM, high efficiency and low standby consumption. Extremely low consumption under no-load conditions is ensured thanks to burst mode operation which reduces the average switching frequency and minimizes all frequency-related losses.

The VIPER38LE operates at a fixed 60 kHz frequency. Frequency jittering is implemented, which helps the application meet electromagnetic disturbance standards.

The IC includes high-level protection features such as dual-level OCP, output overvoltage, short-circuit, and thermal shutdown with hysteresis. After removal of a fault condition, the IC is automatically restarted.

# 1 Schematic diagram

Figure 1. STEVAL-ISA153V1 circuit schematic

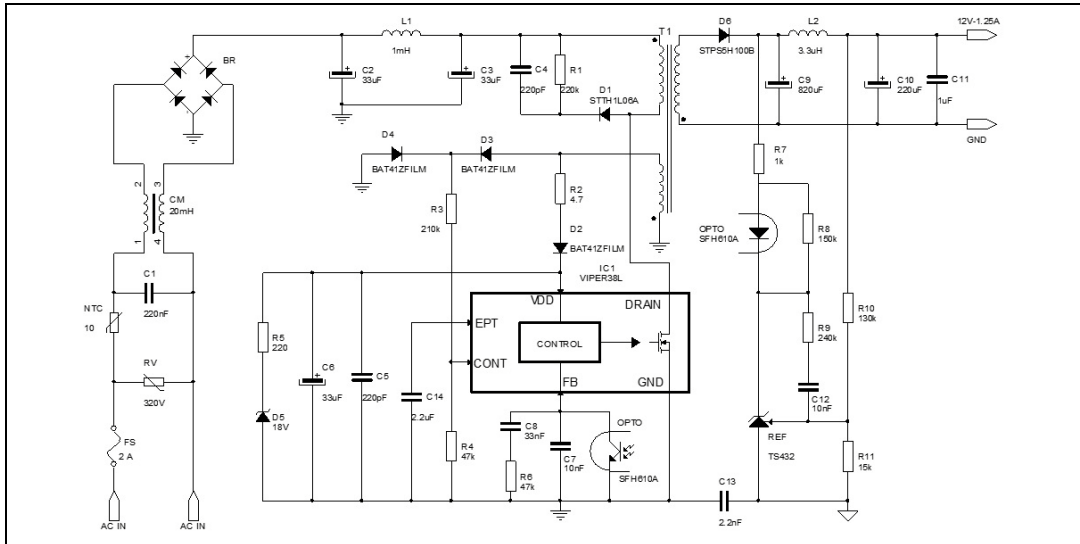

## 2 Revision history

Table 1. Document revision history

Date	Revision	Changes
16-May-2014	1	Initial release.