

1 A constant current DC/DC converter evaluation board based on the L6902D

Data brief

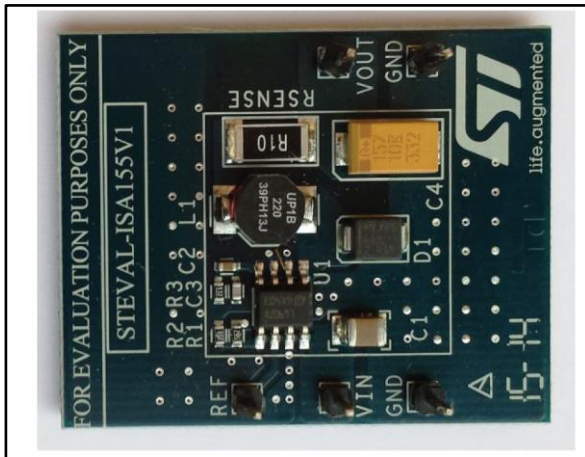

Features

- Up to 1 A output current
- Operating input voltage from 8 V to 25 V
- Precise 3.3 V ($\pm 2\%$) reference voltage
- 5% output current accuracy
- Output voltage adjustable from 1.235 V to 34 V
- 250 kHz internally fixed frequency
- Voltage feedforward
- Zero load current operation
- Adjustable current limit
- Protection against feedback disconnection
- Thermal shutdown
- RoHS compliant

Description

The STEVAL-ISA155V1 product evaluation board integrates the L6902D step-down switching regulator with adjustable current limit, together with the external components required for a typical application. The input voltage of the board can range from 8 V up to 25 V due to the rated voltage of the input capacitor and the Schottky rectifier repetitive peak reverse voltage (both 25 V). The external resistor divider (R1 and R2) sets the output voltage of the application board to 3.3 V. A different output voltage can be regulated from 1.235 V up to 10 V according to the rated voltage of the output capacitor.

A current limit of 1 A is programmed by the 100 m Ω sense resistor (R_{sense}). The inductor saturation current and the forward current of the Schottky rectifier fit the current limit setting.

1 Schematic diagram

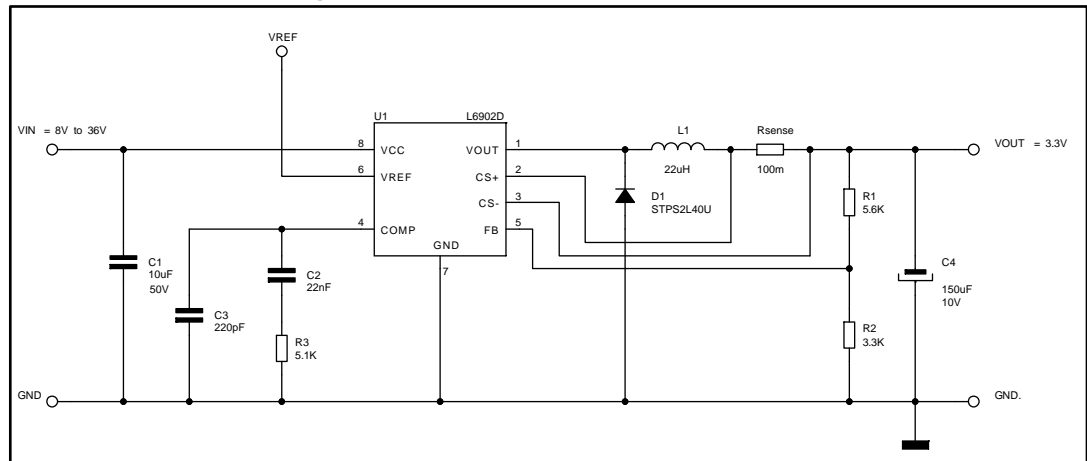
Figure 1: STEVAL-ISA155V1 circuit schematic

2 Revision history

Table 1: Document revision history

Date	Version	Changes
04-Jun-2014	1	Initial release.
04-Dec-2017	2	Modified title in cover page