

16 W triple output quasi resonant flyback converter for air conditioning applications using VIPer35LD

Data brief



Description

The STEVAL-ISA183V1 evaluation board implements a 16 W triple output power supply designed in quasi-resonant flyback topology, specifically designed as an auxiliary PSU for air conditioning systems.

The core of the application is the VIPER35LD high voltage converter from the VIPerPlus product family which integrates an 800 V rugged power MOSFET with a quasi-resonant PWM current-mode control.

The power supply provides an isolated 12 V / 1 A output a two non-isolated outputs, 15 V / 200 mA and 5 V / 200 mA respectively.

Other key features include high conversion efficiency, the extremely low consumption at no-load and at minimum operative output conditions and excellent EMI performance using a low cost input filter.

All of these features are concentrated in a small PCB footprint and a minimal bill of materials.

Features

- AC main input voltage range : 175 V_{AC} to 275 V_{AC}
- Triple output voltages: 12 V - 1 A (isolated), 15 V - 200 mA (non-isolated), 5 V - 200 mA (non-isolated), continuous operation
- High performance at low load conditions: < 50 mW at no-load condition and < 1.5 W input power at minimum operative output power (0.91 W)
- Efficiency at full load: > 81%
- EMI: According to EN55022-Class-B, using low cost input filter
- RoHS compliant

1 Schematic diagrams

Figure 1: STEVAL-ISA183V1 main PSU circuit schematic

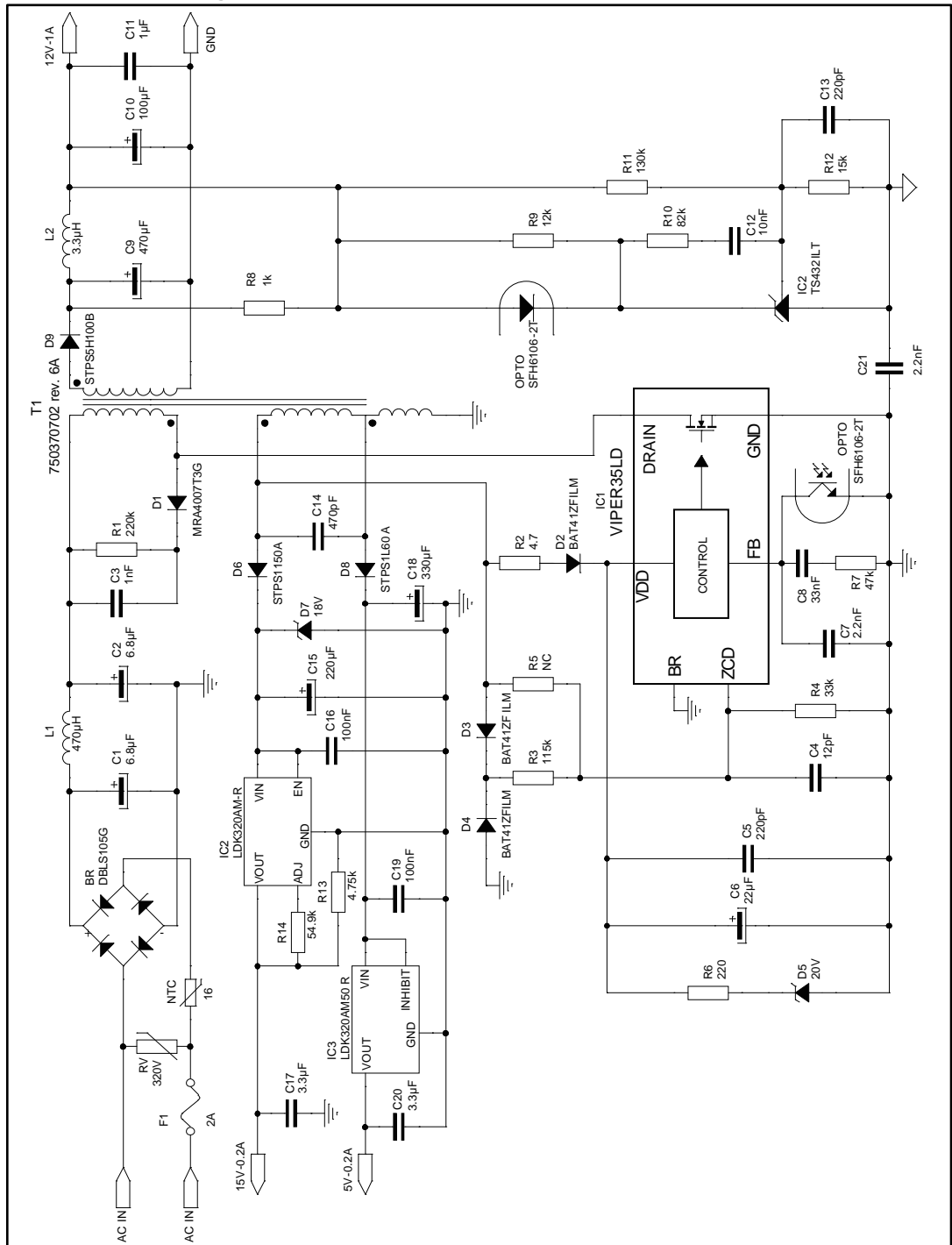

Figure 2: No load consumption vs. input voltage

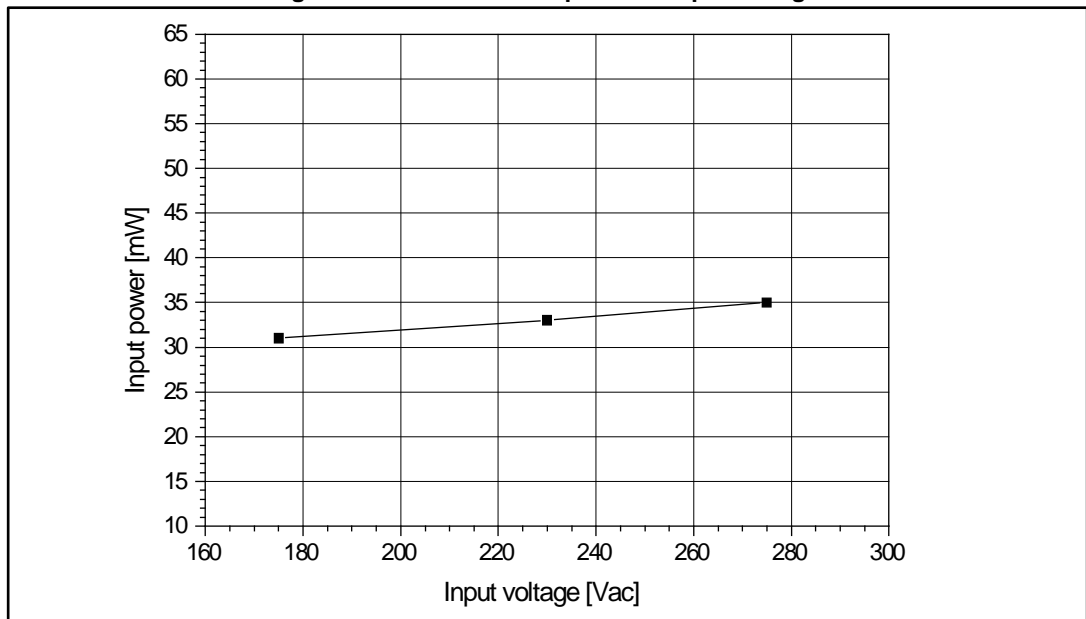

Figure 3: Consumption at minimum load vs. input voltage

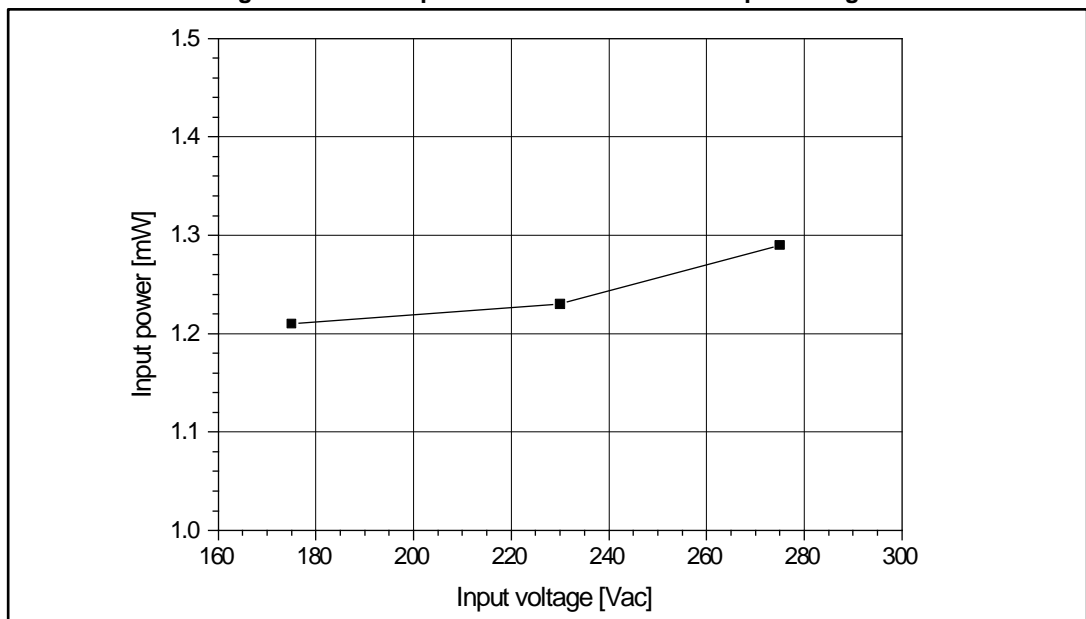

Figure 4: Maximum load efficiency vs. input voltage

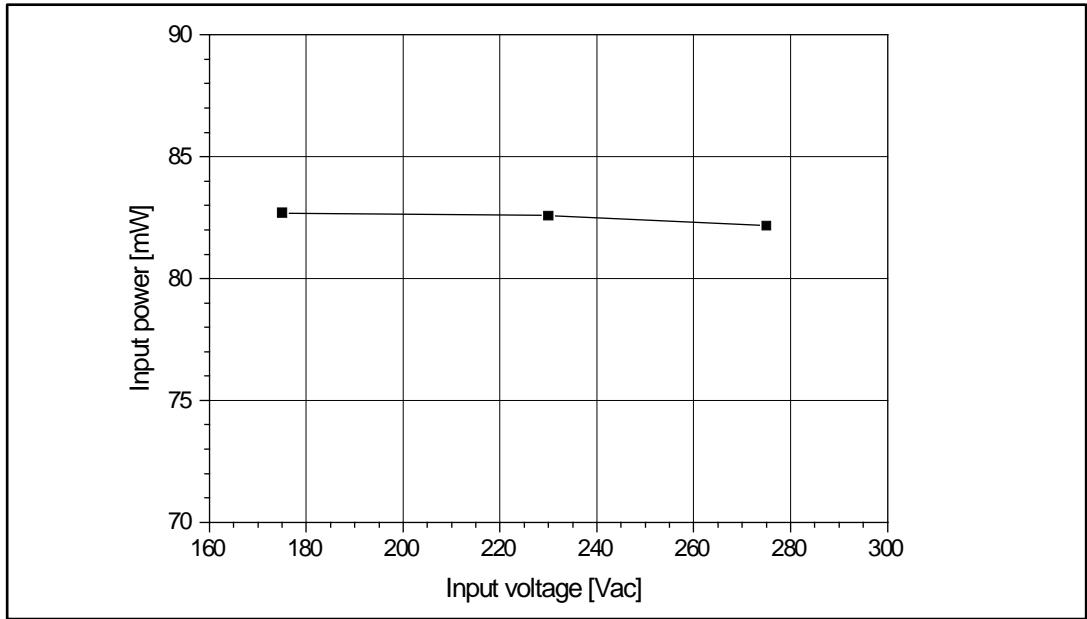
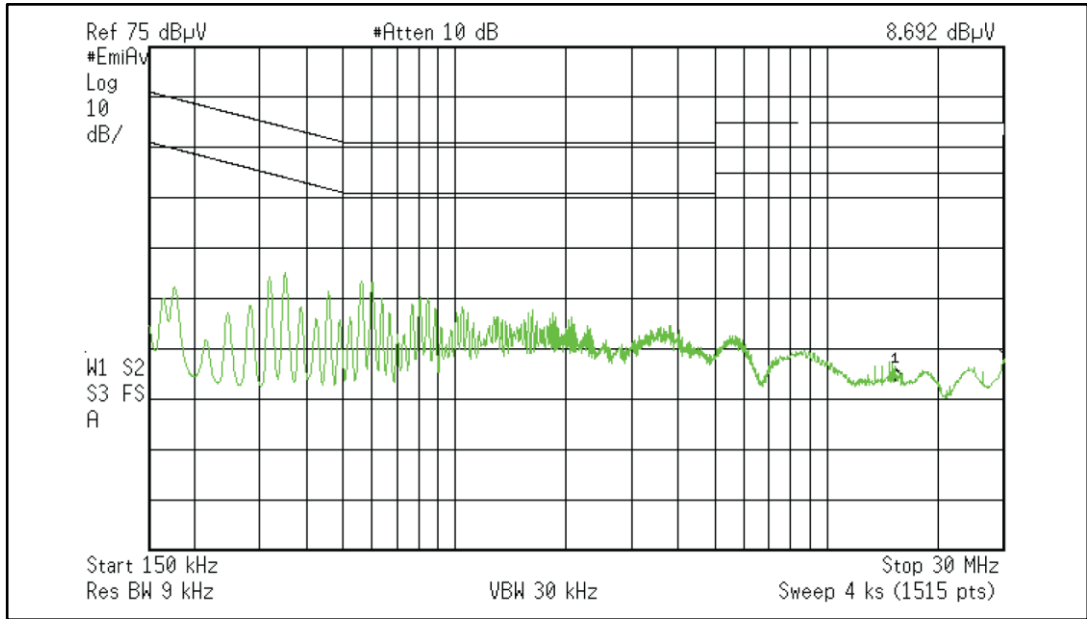

Figure 5: CE average measurement at full load



2 Revision history

Table 1: Document revision history

Date	Version	Changes
15-May-2017	1	Initial release.