

## 5 V / 0.36 A buck converter using VIPerPlus – VIPer11



### Features

- Universal AC main input voltage range: 85 - 265 V<sub>AC</sub>
- Output range: 5 V/0.36 A
- Rated output power: 1.8 W
- Input power in standby at 230 V<sub>AC</sub>: less than 18 mW
- Active mode efficiency: > 65%
- EMI: according to EN55022-Class-B
- RoHS compliant

### Description

The **STEVAL-ISA195V1** evaluation board implements a wide range mains buck converter (5 V/0.36 A) developed for general purpose applications.

The design is built around the **VIPer11** off-line high voltage converter from the VIPerPlus family, which intelligently integrates an 800 V rugged power MOSFET with a current-mode control PWM.

The main characteristics of the evaluation board are its single layer, small size and minimal BoM, high efficiency and low standby consumption.

Product summary	
5 V / 0.36 A buck converter using VIPerPlus - VIPer11	STEVAL-ISA195V1
energy saving off-line high voltage converter	VIPER11
Applications	Home and Professional Appliances Power supplies and Converters

# 1 Schematic diagrams

Figure 1. STEVAL-ISA195V1 circuit schematic

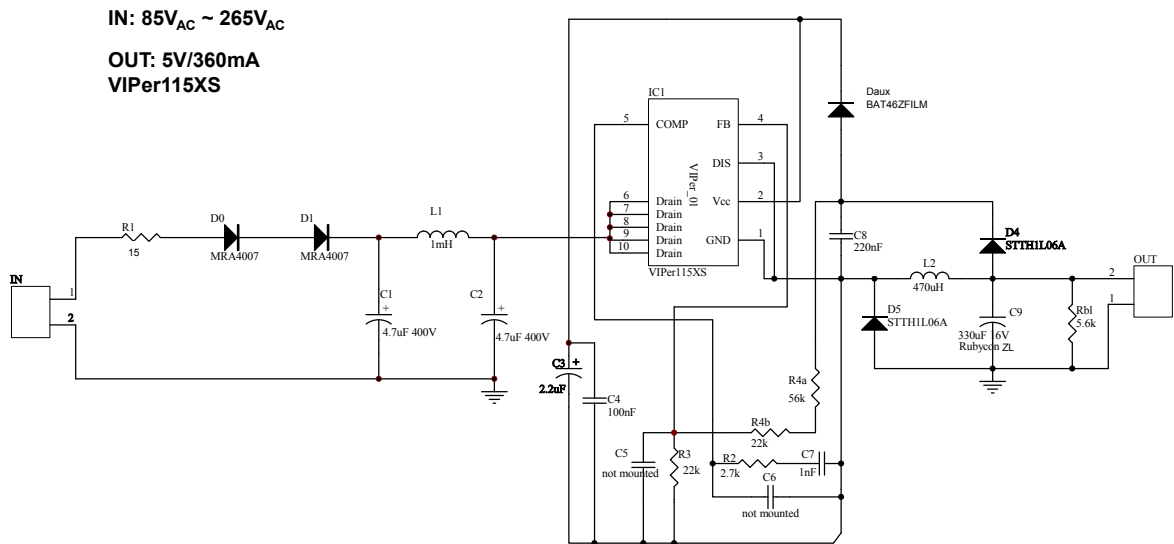

## Revision history

**Table 1. Document revision history**

Date	Version	Changes
09-May-2018	1	Initial release.
11-Dec-2020	2	Updated cover page image and product summary table.