

3 A step-down switching regulator evaluation board based on the L5987

Data brief

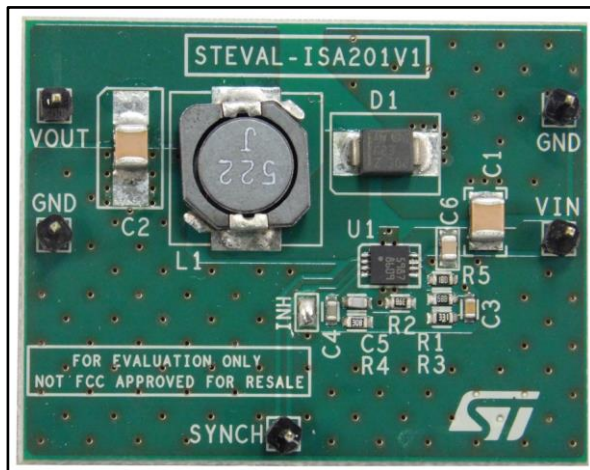

Description

The STEVAL-ISA201V1 product evaluation board provides design engineers with a fully functional step-down switching regulator with an output current of up to 3 A. The STEVAL-ISA201V1 integrates the STMicroelectronics L5987 step-down switching regulator together with all the external components required for a typical application. The rated voltage of the input capacitor and the Schottky diode rectifier repetitive peak reverse voltage are both 25 V, rendering the board capable of covering the entire 2.9 V - 18 V input voltage range of the L5987 device.

The board features an external resistor divider (R1 and R2) designed for an output voltage of 1.8 V. The output voltage can be set to a level from 0.6 V up to V_{IN} . The compensation network on the evaluation board allows the use of an MLCC as output filter to keep the loop stable. The switching frequency on the board is set to 430 kHz by means of the R5 resistor connected to pin F_{SW} .

Features

- 1.8 V, up to 3 A DC output current
- 2.9 V to 18 V input voltage
- Output voltage adjustable from 0.6 V to V_{IN}
- 430 kHz switching frequency, programmable in the range 250 kHz – 1 MHz
- Internal soft-start and inhibit
- Low dropout operation: 100% duty cycle
- Zero-load current operation
- Overcurrent and thermal protection
- VFQFPN8 (3 x 3 mm) package
- RoHS compliant

1 Schematic diagram

Figure 1: STEVAL-ISA201V1 circuit schematic

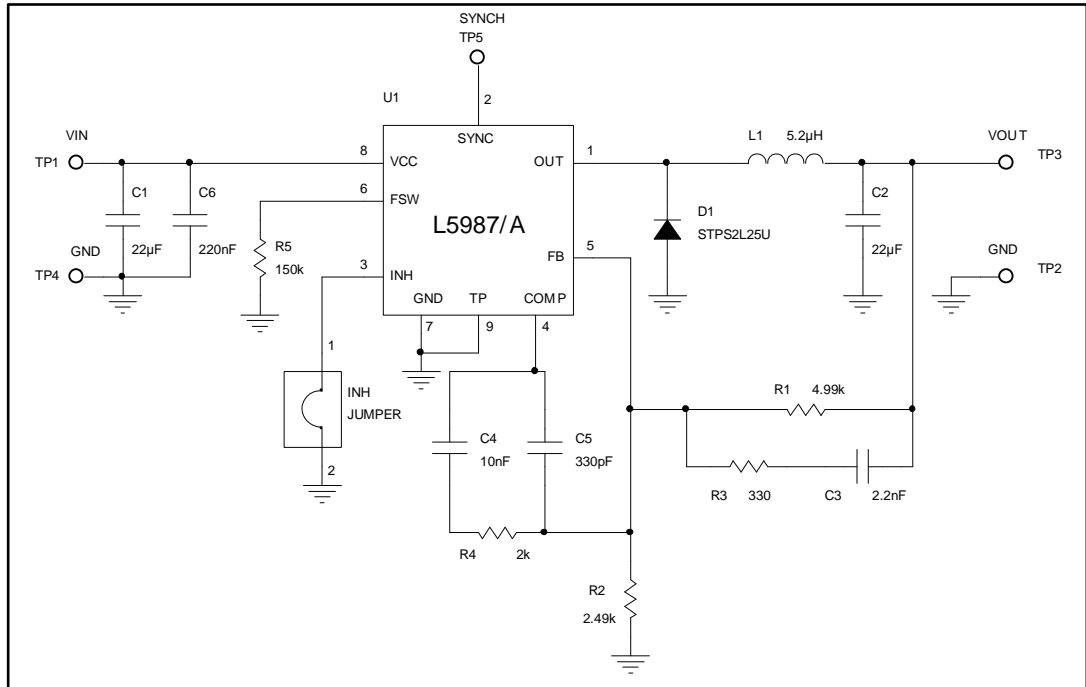

2 Revision history

Table 1: Document revision history

Date	Version	Changes
15-Mar-2017	1	Initial release.