

48 V flyback converter 12 V – 5 A based on PM8804

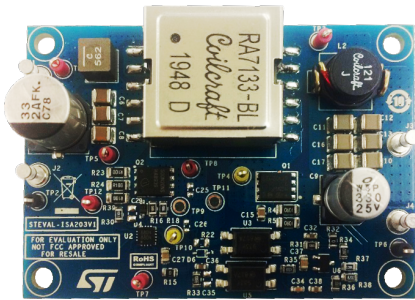

Features

- DC-DC flyback converter based on:
 - [PM8804](#) PWM peak current mode controller, and
 - [SRK1000](#) adaptive synchronous rectification controller
- Input voltage range 42 – 56 V_{DC}
- Switching frequency: 200 kHz
- Output:
 - Power: 60 W
 - Voltage: 12 V_{DC}
 - Current: 5 A
- Peak efficiency > 92%
- RoHS compliant

Description

[STEVAL-ISA203V1](#) evaluation board is designed to demonstrate high efficiency DC-DC conversion with 60 W output (12 V/5 A) from 42 to 56 V_{DC} input (48 V nom.), which is especially suitable for telecom applications.

The power conversion stage is based on a flyback topology managed by the [PM8804](#) controller, which features all the integrated circuitry necessary for a compact and efficient 48 V converter. The highly configurable controller includes a programmable oscillator for switching frequency regulation up to 1 Mhz, adjustable slope compensation, dual complementary low-side drivers with programmable dead time, programmable soft start, soft turn off and a programmable current sense blanking time.

The secondary side employs the [SRK1000](#) adaptive synchronous rectification controller for flyback converters.

Product summary	
48 V flyback converter 12 V – 5 A based on PM8804	STEVAL-ISA203V1
PWM peak current mode controller for PoE and telecom systems	PM8804
Adaptive synchronous rectification controller for flyback converter	SRK1000
N-channel 80 V, 3.0 mΩ typ., 120 A STripFET F7 Power MOSFET in PowerFLAT 5x6 package	STL130N8F7
Application	Server & Telecom Power

1 Application overview

The **STEVAL-ISA203V1** represents a compact and efficient continuous conduction mode flyback converter design with synchronous rectification from 48 V input power, especially suitable for server and telecommunications equipment. The board can supply an output voltage 12 V and load current up to 5 A.

The **PM8804** PWM peak current mode controller integrates two MOSFET drivers with up to 1 A peak sink current capability. The GAT1 signal drives the main switching MOSFET, while the GAT2 signal is capable of controlling a P-channel MOSFET referred to PGND in active clamp flyback topology.

The **SRK1000** flyback synchronous rectification controller takes body diode sensing feedback from the **STL130N8F7** secondary MOSFET.

Figure 1. STEVAL-ISA203V1 block diagram

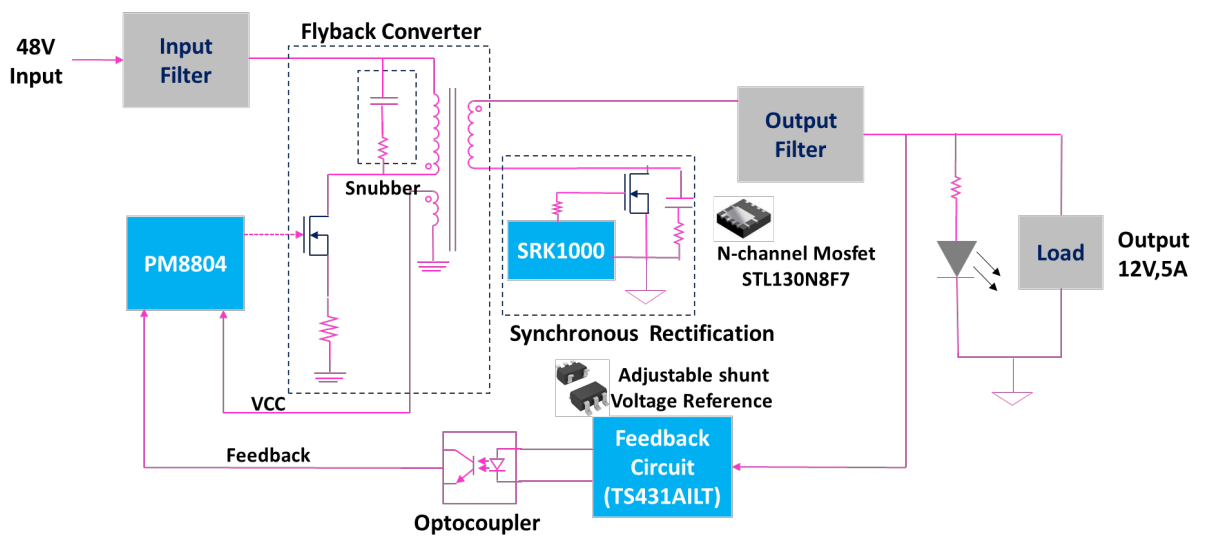

2 Board layout

Figure 2. STEVAL-ISA203V1 top layer

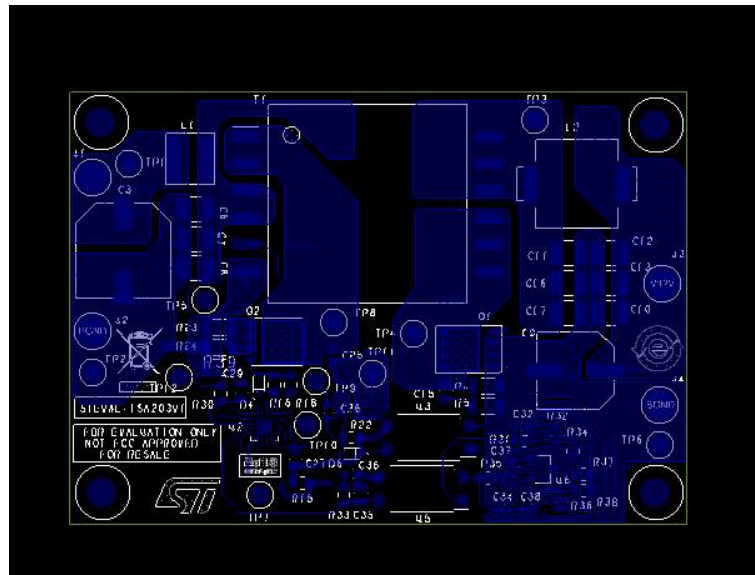

Figure 3. STEVAL-ISA203V1 bottom layer



3 Electrical and efficiency characteristics

Table 1. Electrical specifications of STEVAL-ISA203V1

Electrical specifications	Range / Value
Input voltage range	42-56 V _{DC}
Output voltage	12
Output current	5 A
Total output power	60 W
Maximum efficiency	> 92%

The STEVAL-ISA203V1 evaluation board attains a maximum efficiency of nearly 93%. The figure below shows the efficiency of the board at different input voltages and load conditions.

Figure 4. Efficiency at different load conditions of STEVAL-ISA203V1

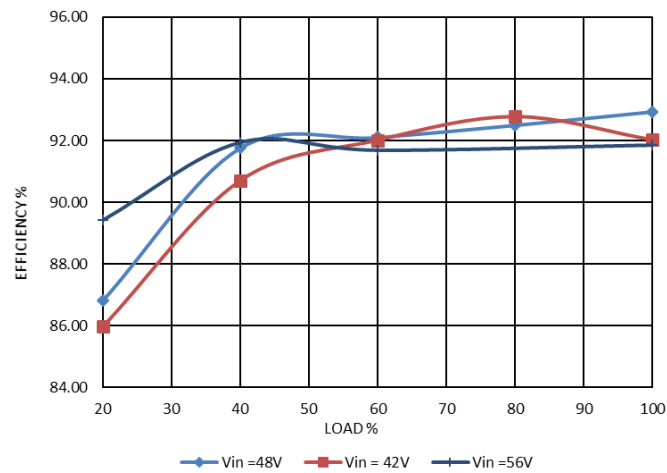
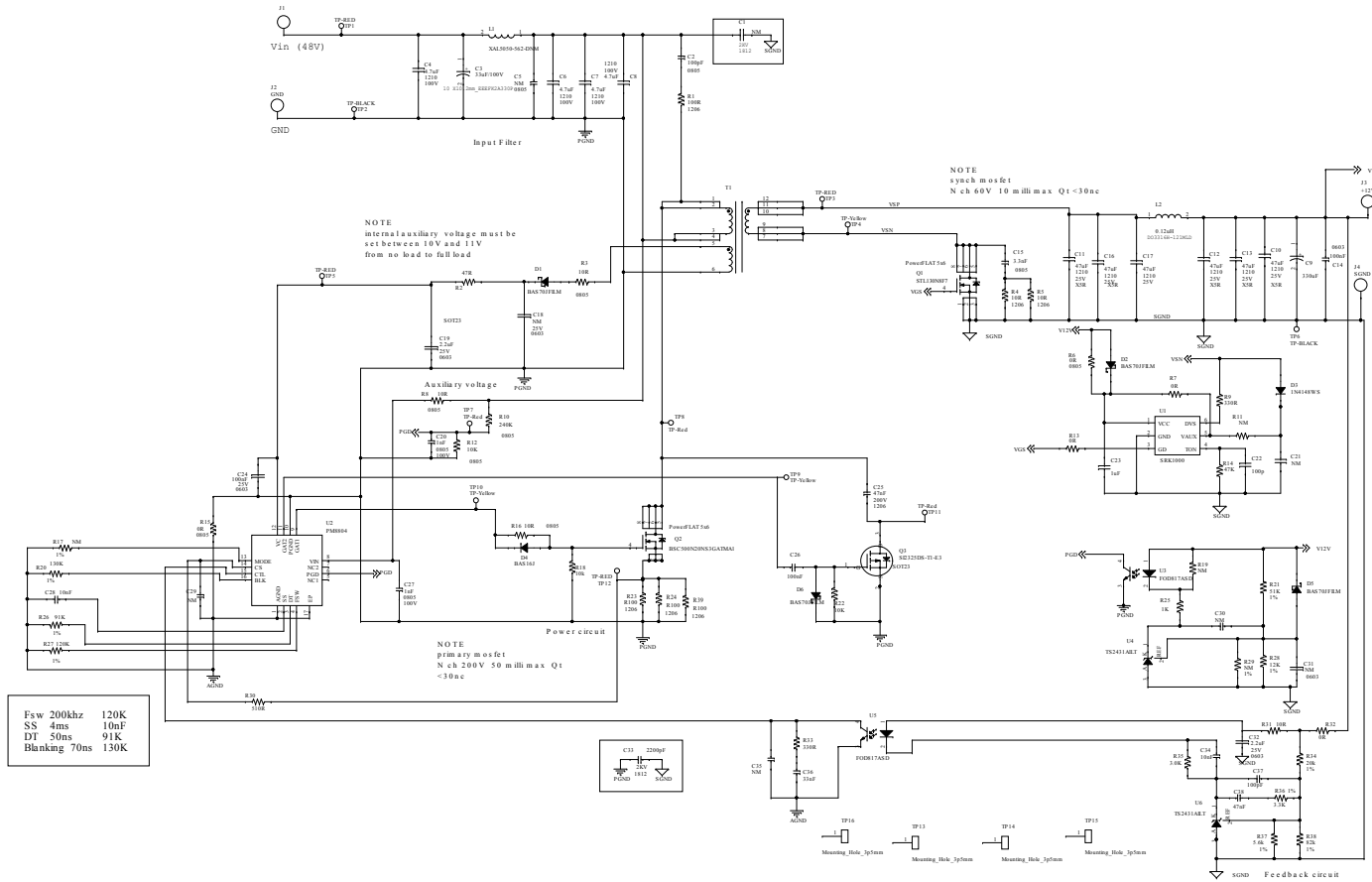

Table 2. STEVAL-ISA203V1 MOSFET temperatures at maximum load (5 A)

Synchronous MOSFET, Q1 STL90N6F7	Synchronous MOSFET, Alternative Q1 STL130N8F7
76 °C	68 °C

4 Schematic diagrams

Figure 5. STEVAL-ISA203V1 board schematic



Revision history

Table 3. Document revision history

Date	Version	Changes
06-Feb-2020	1	Initial release.