



STEVAL-ISB013V1

Battery monitor demonstration board with alarm output for gas gauge applications based on the STC3105

Data brief

Features

- Accurate battery voltage measurement
- Coulomb counter to monitor the battery state-of-charge (SOC)
- Internal 32.768 kHz time base
- Low-battery alarm output with programmable SOC and voltage thresholds
- Relaxation timer to track load condition (user-programmable load current threshold)
- I²C interface for battery monitoring and device control
- Low power consumption:
 - 100 μ A in active operating conditions
 - 50 μ A in power saving operating conditions
 - 2 μ A in standby mode
 - 1 μ A in power-down mode
- RoHS compliant



Description

The STEVAL-ISB013V1 is a demonstration board based on the STC3105 battery monitor IC. The application monitors the voltage and current of a battery and includes a Coulomb counter to keep track of the charge/discharge status.

An alarm output signals a low state-of-charge (SOC) condition and/or low battery voltage. In addition, a relaxation register begins counting when the gas gauge is in a specified light-load condition, indicating when an OCV (open circuit voltage) measurement should be made for SOC correction.

1 Schematic diagram

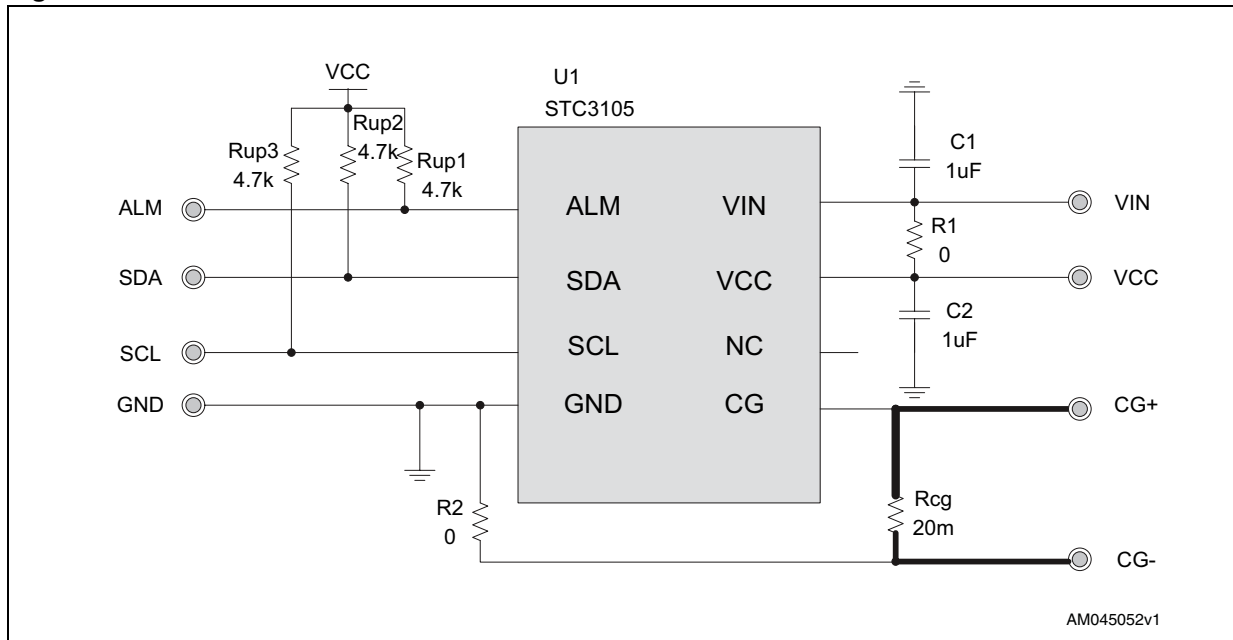
Figure 1. STEVAL-ISB013V1 circuit schematic

2 Revision history

Table 1. Document revision history

Date	Revision	Changes
14-Nov-2011	1	Initial release.