

## Evaluation board for STBCFG01 single-cell Li+ battery charger with OTG boost, voltage mode fuel gauge and 200 mA LDO

Data brief



- USB OTG VBUS generation (500 mA)
  - USB overvoltage protection
  - Programmable battery overcurrent protection
- Automatic 60 mA input pre-bias
- I<sup>2</sup>C compatible control interface
- Interrupt output pin
- RoHS compliant

### Description

The STEVAL-ISB033V1 is an evaluation board to test the first-of-its-kind STBCFG01 switch mode battery charger for single cell Li-Ion batteries, which integrates a highly accurate voltage mode fuel gauge to monitor a battery's state of charge. The device also provides a 5 V output to supply USB OTG (on-the-go) bus-powered devices in addition to an LDO linear voltage regulator to support system boot in dead battery conditions.

The STBCFG01 uses accurate measurements of the battery voltage which allows the estimation of the battery's state-of-charge (SOC) without a current-sensing resistor. The switching charger works together with the fuel gauge to simplify monitoring features and to save current consumption when the device is not charging. The battery charger features a smart input current limit; the maximum input current can be selected through the I<sup>2</sup>C interface, and if the input voltage drops below a programmable threshold, even if the selected maximum current limit current has not been reached yet the dynamic input current limit function is activated, preventing the input current from increasing further. The dynamic input current limit function can be disabled, if necessary. An automatic input pre-bias load makes the device suitable for applications using voltage sources requiring a minimum external load for correct regulation.

### Features

- High-efficiency switching battery charger
  - 2 MHz or 3 MHz switching frequency
  - 1.2 A max. charging current
  - 20 V tolerant input with OVP
  - Programmable input current limitation and dynamic input current limit
  - Battery overvoltage protection
  - Auto-recharge
  - Integrated current sensing resistor
  - USB compatible
- Voltage mode fuel gauge
  - External sensing resistor not needed
  - Battery swap detection through ID resistor
  - Low battery voltage and low SOC programmable alarms
- 50 mA LDO for system boot in dead battery condition

# 1 Schematic diagram

Figure 1: STEVAL-ISB033V1 circuit schematic

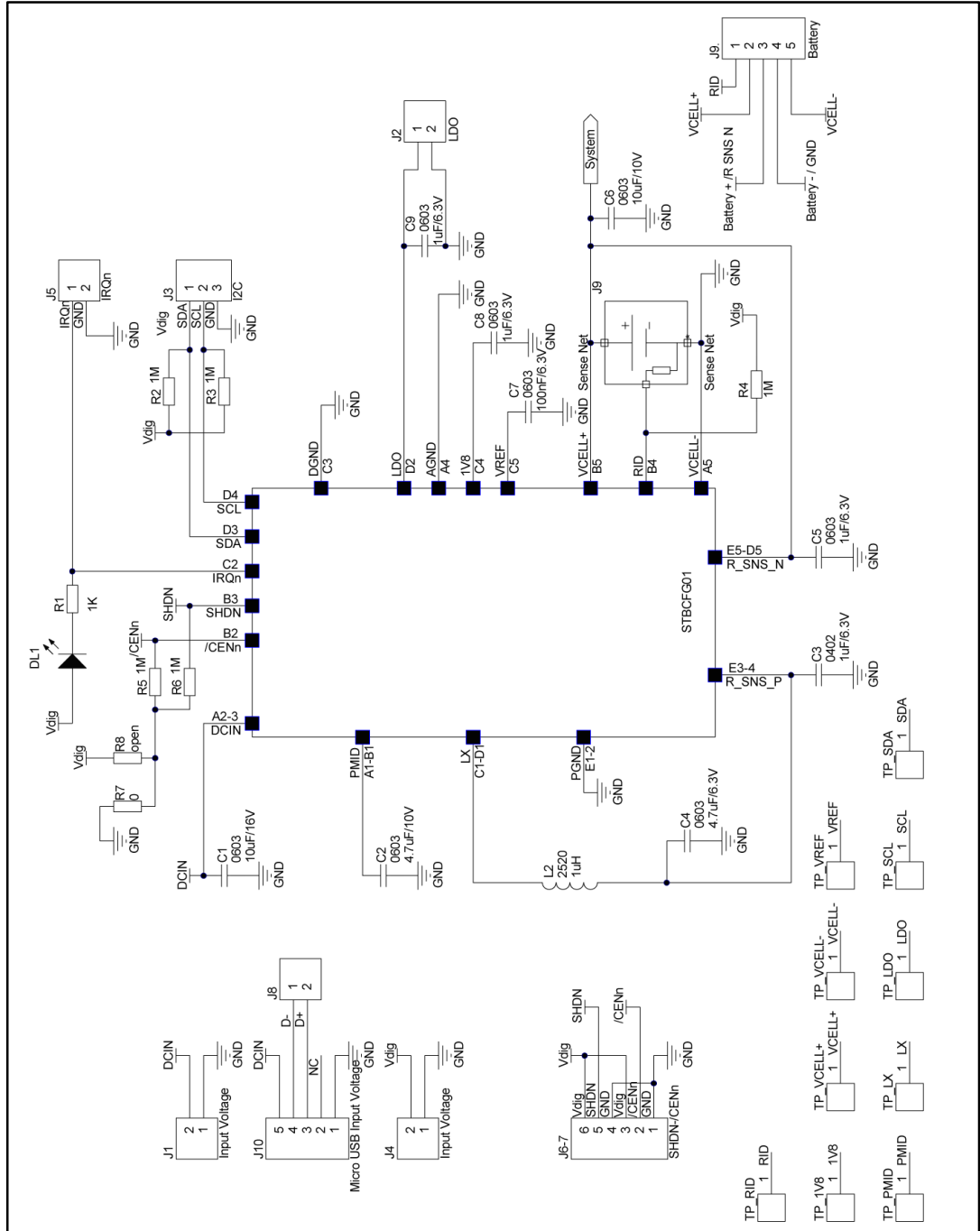

## 2 Revision history

Table 1: Document revision history

Date	Version	Changes
17-Apr-2015	1	Initial release.