



STEVAL-ISQ007V1

High-side current-sense amplifier demonstration board based on the TSC101

Data Brief

Features

- Independent supply and input common-mode voltages
- Wide common-mode operating range: 2.8 V to 30 V
- Wide common-mode surviving range: -0.3 V to 60 V (load-dump)
- Wide supply voltage range: 4 V to 24 V
- Low current consumption: ICC max is 300 μ A
- Internally fixed gain:
 - 20 V/V (TSC101A)
 - 50 V/V (TSC101B)
 - 100 V/V (TSC101C)
- Buffered output

Description

This demonstration board is specifically designed for the TSC101 integrated circuit.

The TSC101 measures a very small voltage drop on a high-side shunt resistor, and, using an internally fixed gain, amplifies the difference into a ground-referenced output voltage; the amplification gain is internally fixed.

Input common-mode and power supply voltages are independent.

The common-mode voltage can range from 2.8 V to 30 V in operating conditions, and up to 60 V in absolute maximum ratings.

The supply voltage can range from 4 V to 24 V.

Current consumption of less than 300 μ A over the temperature range and low input bias current (less than 8 μ A in standard conditions, a few 100 nA if VCC isn't supplied) are particularly interesting to save power in the application.

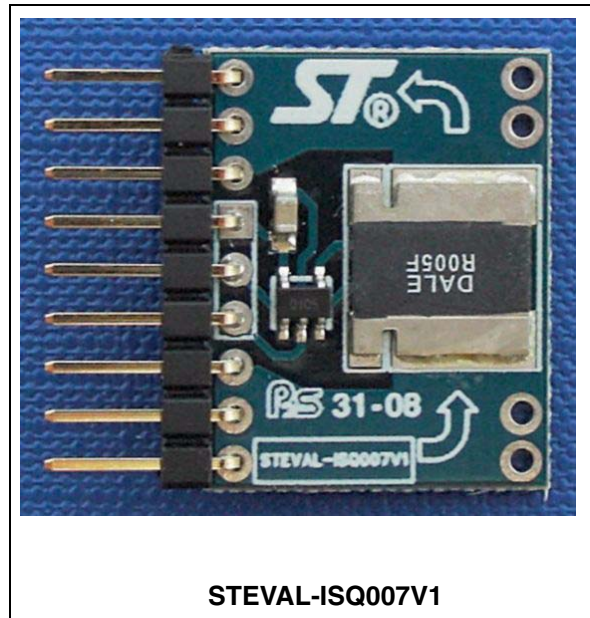

1 Circuit schematic

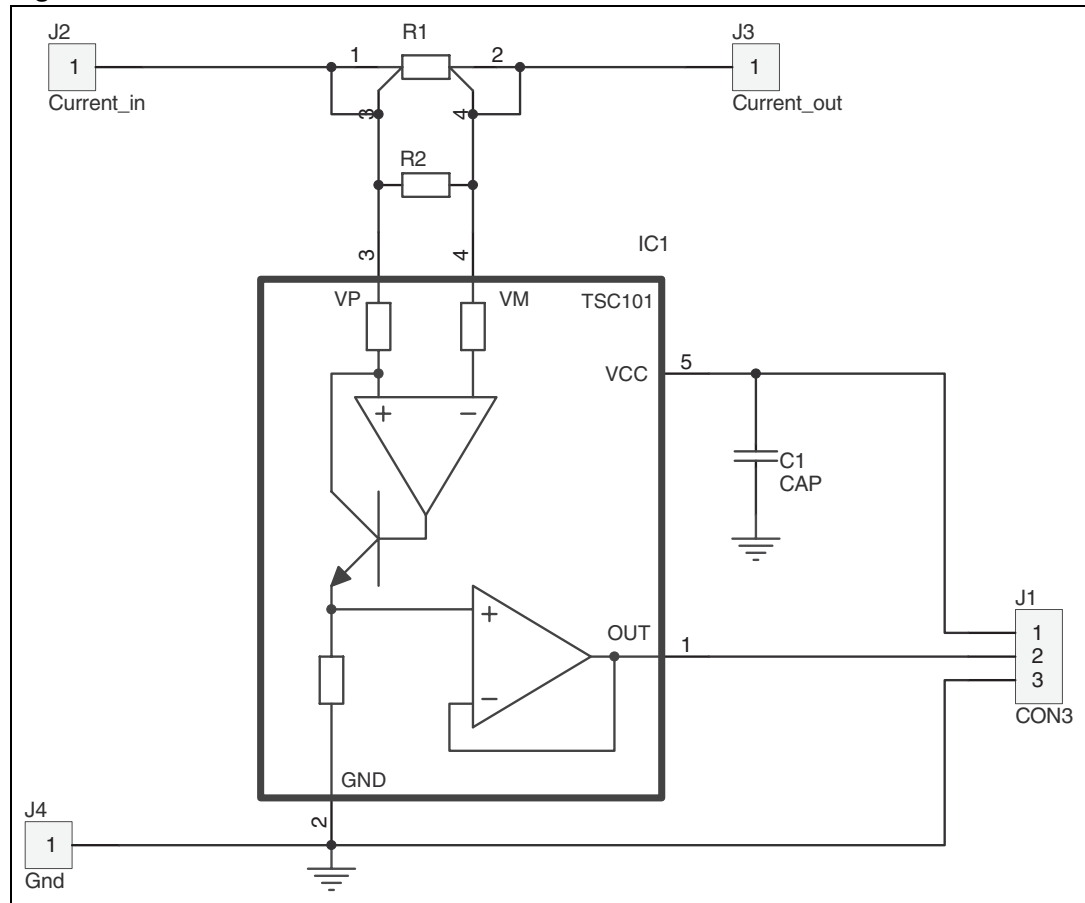
Figure 1. Schematic

2 Revision history

Table 1. Document revision history

| Date | Revision | Changes |
|-------------|----------|------------------|
| 12-Feb-2009 | 1 | Initial release. |