



STEVAL-ISQ010V1

High-side current-sense amplifier demonstration board based on the TSC102

Data brief

Features

- Independent supply and input common-mode voltages
- Wide common-mode operating range: 2.8 V to 30 V
- Wide common-mode survival range: -16 V to 60 V (reverse battery and load-dump conditions)
- Low current consumption: I_{CC} max = 450 μ A
- Internally fixed gain: 20 V/V
- Integrated fully-accessible operational amplifier for tailor-made signal conditioning
- RoHS compliant



Description

The STEVAL-ISQ010V1 demonstration board is specifically designed for the TSC102 device.

The TSC102 measures a very small voltage drop on a high-side shunt resistor and, using an internally fixed gain, amplifies the difference into a ground-referenced output voltage. The amplification gain is internally fixed. The device is housed in a tiny TSSOP8 package.

Input common-mode and power supply voltages are independent. The common-mode voltage can range from 2.8 V to 30 V during operation. Under absolute maximum rating conditions, the Vp and Vm pins can sustain as much as 60 V to handle events like load-dump conditions, and as low as -16 V to deal with reverse battery conditions.

The supply voltage can range from 3.5 V to 5.5 V, therefore the TSC102 can be supplied by the same voltage regulator used for digital circuits.

Current consumption is less than 450 μ A over the temperature range, and low input bias current is less than 7 μ A in standard conditions.

1 Schematic diagram

Figure 1. STEVAL-ISQ010V1 circuit schematic

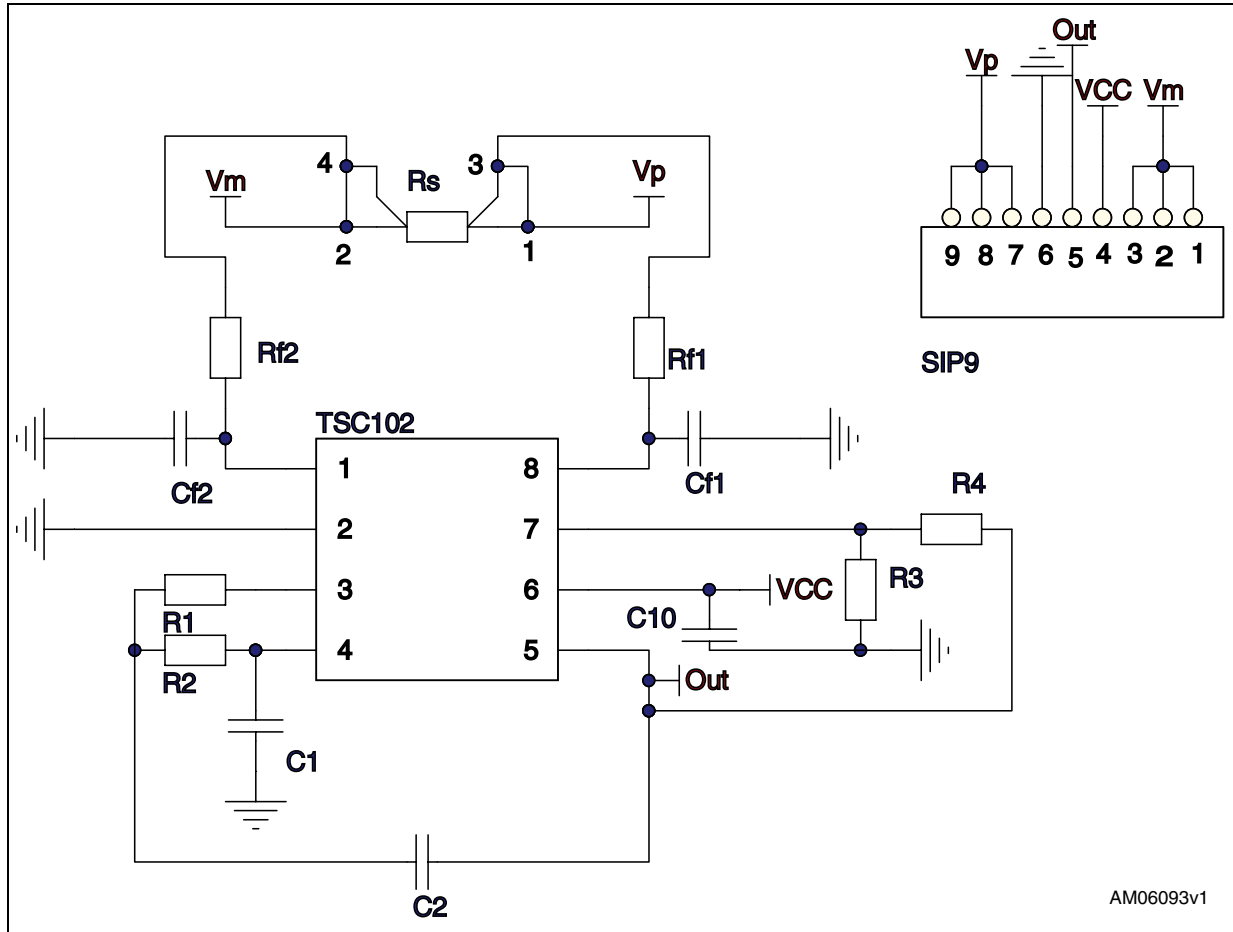

2 Revision history

Table 1. Document revision history

Date	Revision	Changes
08-Mar-2010	1	Initial release.