



# STEVAL-ISQ013V1

## Low-side current sensing demonstration board based on the TS507

Data brief

### Features

- Ultra low offset voltage: 25  $\mu$ V typ, 100  $\mu$ V max
- Rail-to-rail input/output voltage swing
- Operating from 2.7 V to 5.5 V
- High speed: 1.9 MHz
- 45° phase margin with 100 pF
- Low consumption: 0.8 mA at 2.7 V
- Very large signal voltage gain: 131 dB
- High power supply rejection ratio: 105 dB
- Very high ESD protection 5 kV (HBM)
- Latch-up immunity
- RoHS compliant



### Description

Current sensing is very useful for protecting applications. The STEVAL-ISQ013V1 demonstration board implements a low-side current sensing which consists in placing a sense resistor between the load and the circuit ground and the resulting voltage drop is amplified using a TS507 op amp.

The common mode voltage is close to ground, whatever the voltage of the power source, so the current sense voltage can be amplified by this low voltage op amp without any restrictions.

The circuit offers very stable electrical characteristics over the entire supply voltage range and is particularly intended for automotive and industrial applications.

# 1 Schematic circuit

Figure 1. Internal schematic

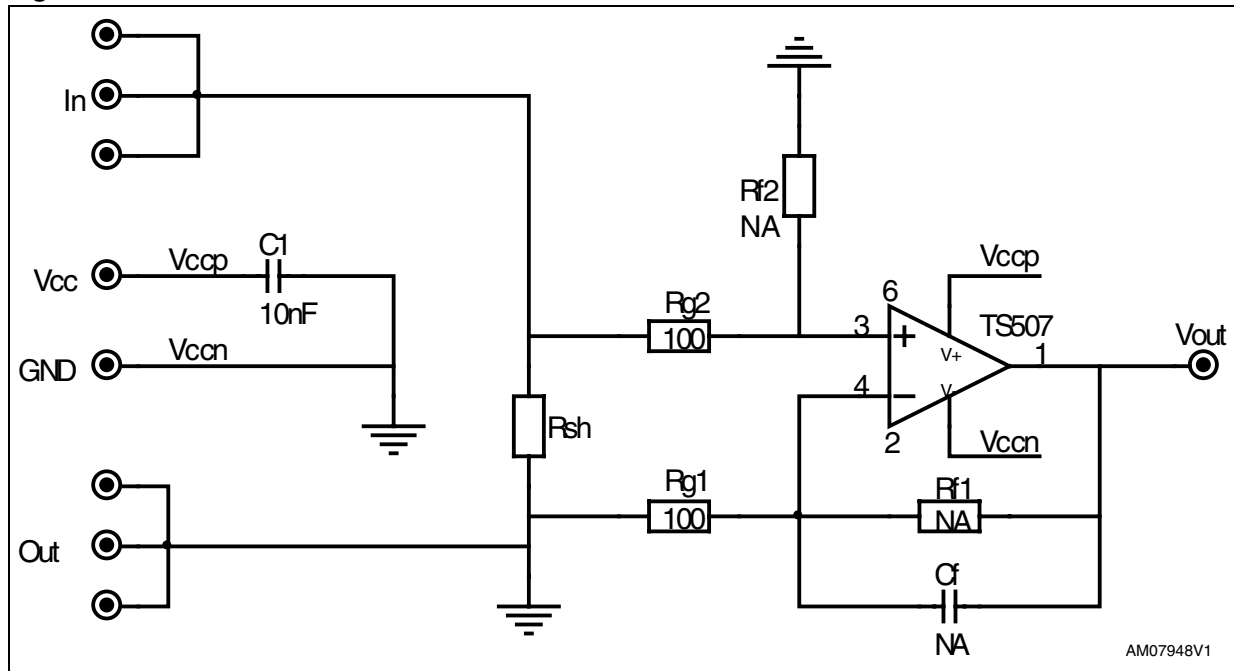

## 2 Revision history

**Table 1. Document revision history**

Date	Revision	Changes
23-Aug-2010	1	Initial release.