



STEVAL-ISV006V2

Up to 5 W solar battery charger with embedded MPPT based on the SPV1040

Data brief

Features

- High-efficiency monolithic step-up DC-DC converter
- Proprietary “perturb & observe” embedded MPPT algorithm
- Very low input voltage (down to 0.3 V)
- Integrated N-channel and P-channel MOSFETs with low R_{ON} resistance
- Overcurrent and overtemperature protection
- Input reverse polarity protection
- LED charge status indicator
- RoHS compliant

Description

The STEVAL-ISV006V2 demonstration board is based on the SPV1040 high efficiency solar battery charger with embedded MPPT. The SPV1040 device is a low power, low voltage, monolithic step-up converter with an input voltage range from 0.3 V to 5.5 V, and is capable of maximizing the energy generated by even a single solar cell (or fuel cell), where low input voltage handling capability is extremely important.

Thanks to the embedded MPPT algorithm, even under varying environmental conditions (such as irradiation, dirt, temperature) the SPV1040 offers maximum efficiency in terms of power harvested from the cells and transferred to the output.

The device employs an input voltage regulation loop, which fixes the charging battery voltage via a resistor divider. The maximum output current is set with a current sense resistor according to charging current requirements.

The SPV1040 protects itself and other application devices by stopping the PWM switching if either the maximum current threshold (up to 2 A) is reached or the maximum temperature limit (up to 155 °C) is exceeded.



The STEVAL-ISV006V2 demonstration board is supplied by a PV panel with P_{PK} of 200 mW, which can be replaced with PV panels with P_{PK} up to 5 W ($V_{OC} < 5$ V) depending on application requirements.

The output load is a 220 mF, 5.5 V super-capacitor that can be replaced with lead-acid, NiCd or NiMh rechargeable batteries (max voltage = 5 and $> V_{OC}$ of the selected PV panel).

The demonstration board provides a simple charge status indicator using 2 LEDs, and 3 trimmers are available to allow setup according to the specific application requirements.

1 Schematic diagram

Figure 1. STEVAL-ISV006V2 circuit schematic

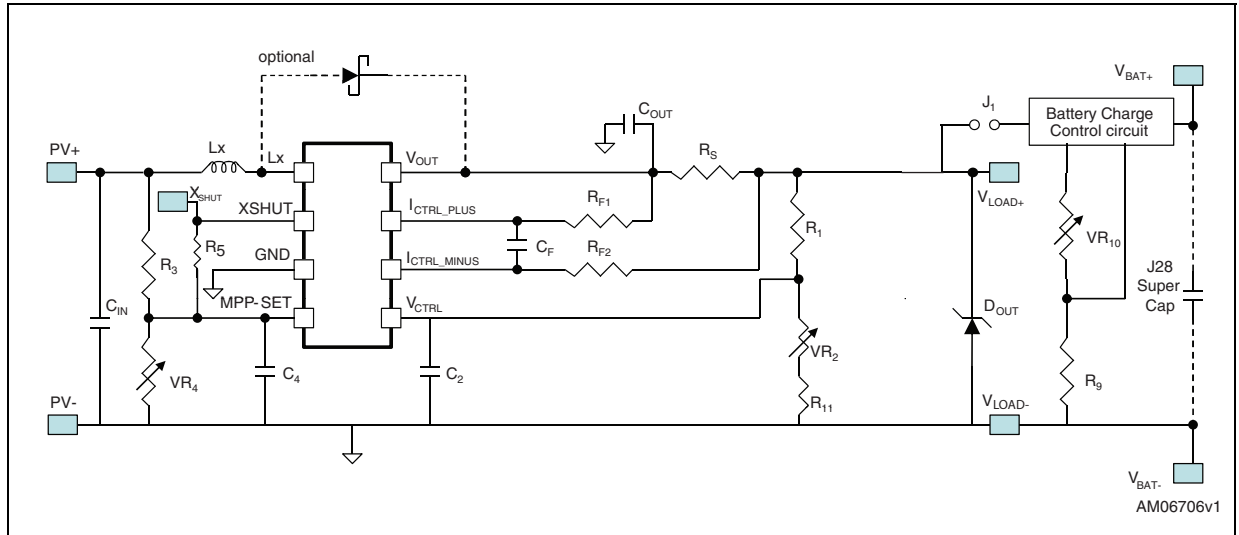

2 Revision history

Table 1. Document revision history

Date	Revision	Changes
25-Mar-2011	1	Initial release.
05-May-2011	2	Updated: Figure 1: STEVAL-ISV006V2 circuit schematic.
11-Oct-2011	3	Updated: figure of the board in cover page