

Evaluation board for SPV1050 ULP energy harvester and battery charger – boost configuration

Data brief

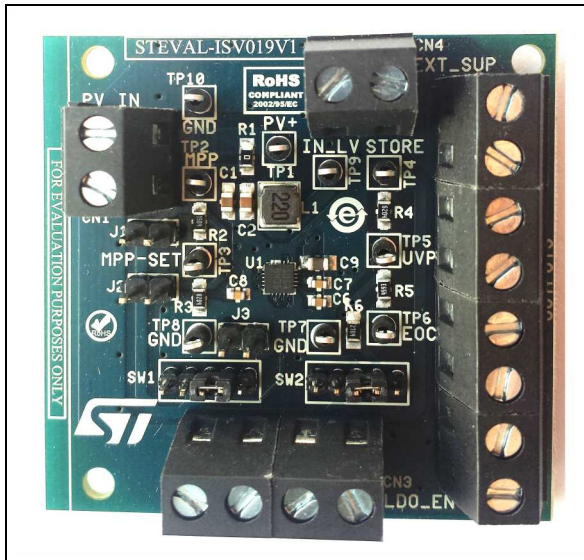

Features

- First startup at $V_{in} = 500 \text{ mV}$
- Input voltage working range:
 $150 \text{ mV} \leq V_{in} \leq V_{EOC}$
- End of charge battery voltage: $V_{EOC} = 4.25 \text{ V}$
- Battery undervoltage protection: $V_{UVP} = 3.7 \text{ V}$

Applications

- Charge any battery chemistry, including lithium based, NiMH, solid state thin film and supercapacitor.
- WSN, HVAC, building and home automation, industrial control, access control, smart lighting, asset and livestock positioning and tracking, surveillance.
- Body area network, sportswear, fitness.

Description

The STEVAL-ISV019V1 is an evaluation board based on the ultralow power energy harvester and battery charger SPV1050. For any detail related to the SPV1050 features and performances please refer to the datasheet.

The evaluation board implements the boost configuration of the DC-DC converter and has the purpose of enhancing the SPV1050 based applications development by testing the silicon performance thanks to many jumpers and test points, and by helping to find out the best system configuration to make the SPV1050 device working at the most of efficiency.

The STEVAL-ISV019V1 is optimized to:

Harvest energy from PV panels supplying $0.5 \text{ V} \leq V_{MP} \leq 2.5 \text{ V}$ and $30 \mu\text{A} \leq I_{MP} \leq 20 \text{ mA}$.

Charge a battery with 3.7 V undervoltage protection threshold (V_{UVP}) and 4.2 V end of charge voltage threshold (V_{EOC}).

Nevertheless, few easy changes on the application components (input and output resistor partitioning, C_{IN} capacitor) allow to use a different PV panel and source (like TEG), and a battery by setting the V_{MPP_SET} , the V_{UVP} and the V_{EOC} thresholds according to the new source and load. More in detail, operating ranges can be extended as follows: V_{MP} from 150 mV up to 5 V , I_{MP} up to 100 mA , V_{UVP} down to 2.2 V and V_{EOC} up to 5.3 V .

1 Schematic and bill of material

The schematic, bill of material and gerber files can be downloaded from the Design resources tab of the STEVAL-ISV019V1 product folder on www.st.com.

Figure 1. Schematic

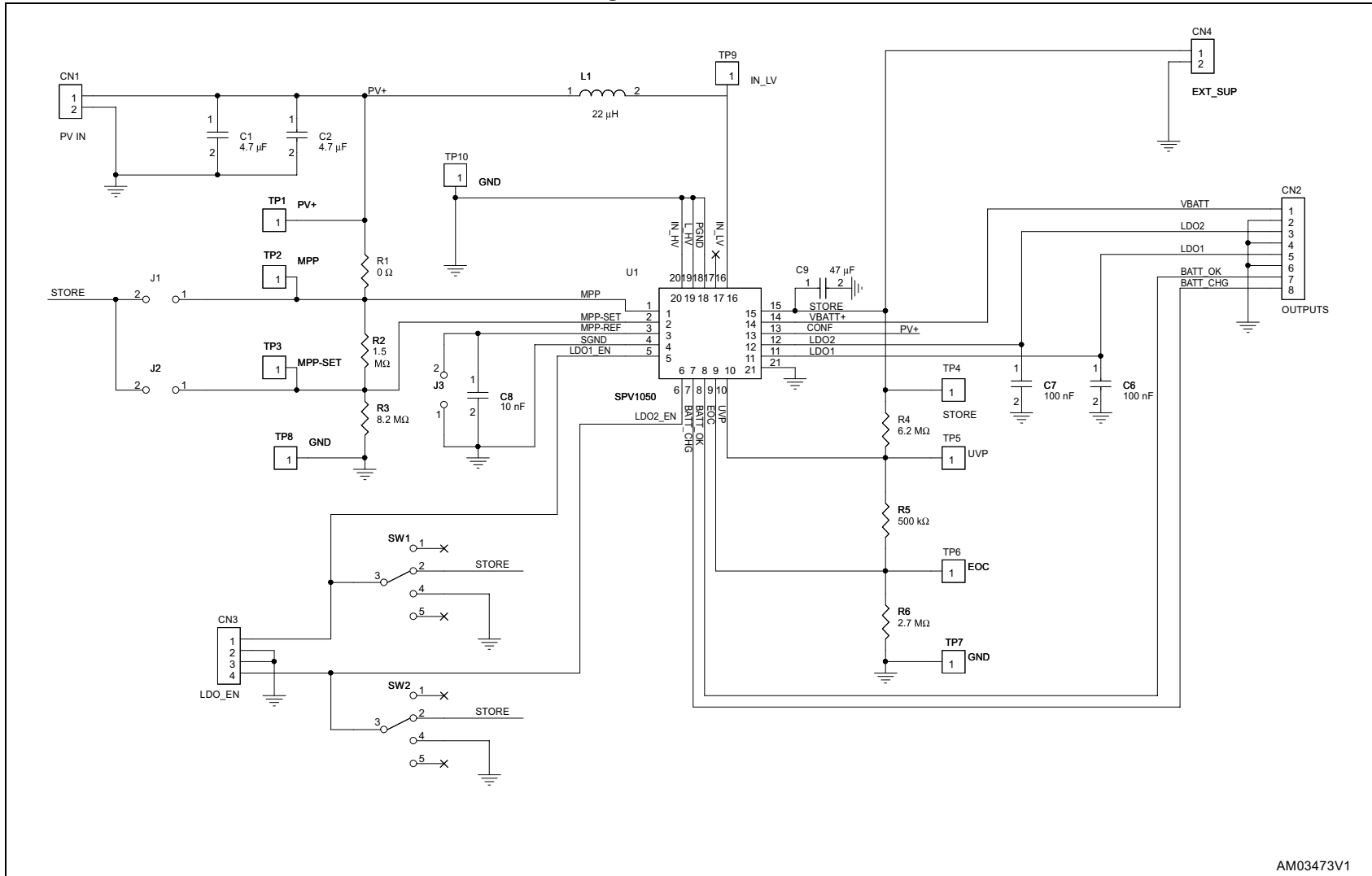

AM03473V1



Table 1. Bill of material

Sect.	Item	Q.ty	Reference	Part / value	Toler. %	Voltage current	Watt	Technol. info.	Package	Manufacturer	Manufacturer code	More information	
DC-DC input section	1	1	U1	SPV1050					VFQFPN 3 x 3 x 1 20L (code A0BR)	ST	SPV1050		
	2	1	CN1	2-ways screw connector						TE Connectivity	282834-2	Input connector for PV panel or TEG	
	3	1	C1	4.7 μ F	15%	16 V			0805	Murata	GCM21BR71C475KA73L	Input capacitance	
	4	0	C2 (DNM)	4.7 μ F	15%	16 V			0805	Murata	GCM21BR71C475KA73L		
	5	3	J1, J2, J3	jumper					Pitch 2.54 mm	TH			Enable/disable MPPT
	8	1	R1	0 Ω	1%					0805	VISHAY	CRCW08052M70FKEA	Resistor partitioning for MPP track/setting
	9	1	R2	1.5 M Ω	1%					0805	VISHAY	CRCW08051M50FKEA	
	10	1	R3	8.2 M Ω	1%					0805	YAGEO	232273468205	
	11	1	L1	22 μ H	20%						Coilcraft	LPS4018-223ML_	DC-DC inductor
	12	1	C8	10 nF	15%	16 V			X7R	0603	Murata	GRM188R71C103KA01D	Voltage sampling time constant capacitance

Table 1. Bill of material (continued)

Sect.	Item	Q.ty	Reference	Part / value	Toler. %	Voltage current	Watt	Technol. info.	Package	Manufacturer	Manufacturer code	More information
Battery section	13	1	CN4	2-way screw connector						TE Connectivity	282834-2	Connector for external supply of pin STORE
	14	1	C9	47 μ F	20%	10 V			0805	TDK	C2012X5R1A476M125AC	
	15	1	R4	6.2 M Ω	5%				0805	RS	RS-0805-6m2-5%-0.125W	Resistor partitioning for UVP, EOC, protection setting
	16	1	R5	499 k Ω	1%				0805	VISHAY	CRCW0805499KFKEA	
	17	1	R6	2.7 M Ω	1%				0805	VISHAY	CRCW08052M70FKEA	
	18	1	CN2	8-way screw connector						TE Connectivity	282836-8	Connector for battery and battery status signals
LDOs section	19	2	C6, C7	100 nF	10%			X7R	0603	KEMET	C0603C104K4RAC	Tank capacitor for LDOs
	21	2	SW1, SW2	5-pin male Stripline				Pitch 2.54 mm	TH			Close 2 - 3: LDO disabled Close 1 - 2: LDO enabled Floating: external control through CN3
	23	1	CN3	4-way screw connector						TE Connectivity	282836-4	Connector for LDOs enable connection



Table 1. Bill of material (continued)

Sect.	Item	Q.ty	Reference	Part / value	Toler. %	Voltage current	Watt	Technol. info.	Package	Manufacturer	Manufacturer code	More information
List of test points	25	1	TP1					True hole				PV+ pin sensing and soldering
	26	1	TP2					True hole				MPP pin sensing and soldering
	27	1	TP3					True hole				MPP-SET pin sensing and soldering
	28	1	TP4					True hole				STORE pin sensing and soldering
	29	1	TP5					True hole				ULP pin sensing and soldering
	30	1	TP6					True hole				EOC pin sensing and soldering
	31	1	TP7					True hole				GND pin sensing and soldering
	32	1	TP8					True hole				GND pin sensing and soldering
	33	1	TP9					True hole				IN_LV pin sense (for probe scope)
	34	1	TP10					True hole				GND pin sensing (for probe scope)

2 Layout

From *Figure 2* to *Figure 4* show the component placement and the layout (top and bottom views) of the STEVAL-ISV019V1.

Figure 2. Layout - silkscreen view

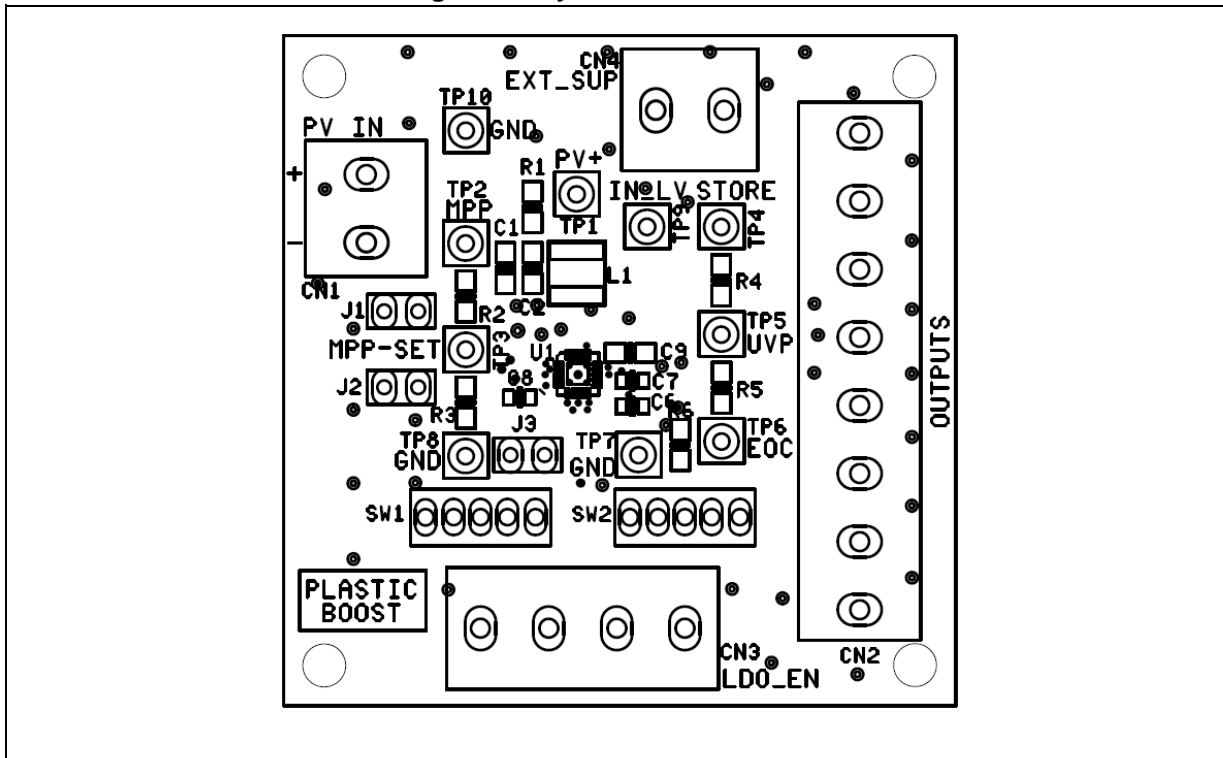

Figure 3. Layout - top view

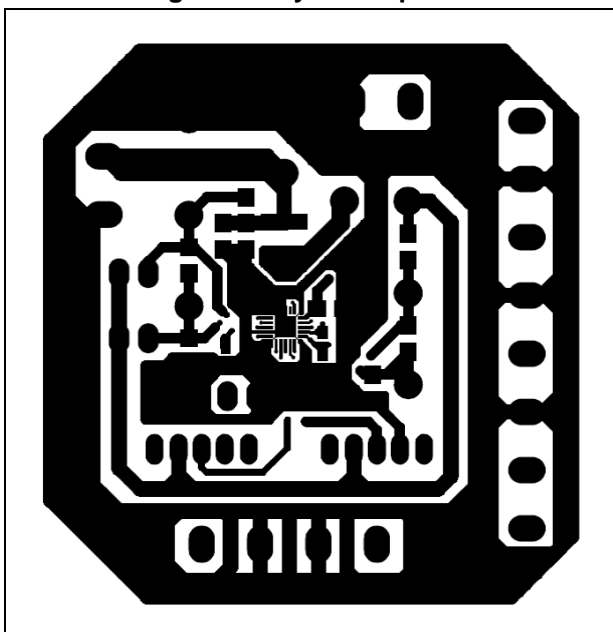
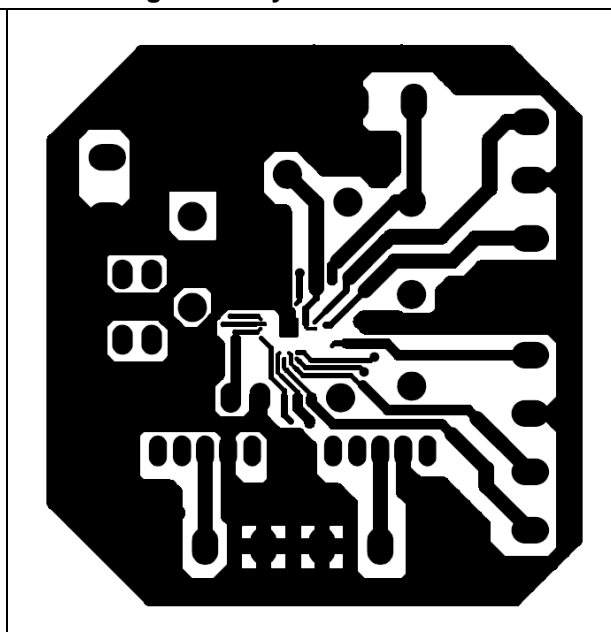

Figure 4. Layout - bottom view



3 Revision history

Table 2. Document revision history

Date	Revision	Changes
27-Nov-2013	1	Initial release.
29-Apr-2014	2	<p>Updated Section : Features on page 1 (updated values of “First startup at Vin” and “Input voltage working range”).</p> <p>Updated Section : Description on page 1 (updated values of “Harvest energy from PV panels supplying”, added extended operating ranges).</p> <p>Updated Section 1: Schematic and bill of material on page 2 (updated web link).</p> <p>Updated Figure 1: Schematic on page 3 (updated value of C9 capacitor, minor modifications).</p> <p>Updated Table 1: Bill of material on page 4 (removed “PV panel” item, updated values and manufacturer information of C9 capacitor, updated “Technol. info.” of J1, J2, J3 jumper, quantity of R6 item, item numbers and “More information” for several items).</p> <p>Minor modifications throughout document.</p>
13-Nov-2014	3	Updated figure in cover page.