

38 V, 5 W synchronous iso-buck converter evaluation board with dual isolated output based on the L6986I

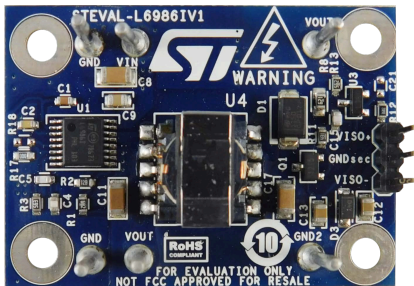

Features

- Designed for iso-buck topology
- 4 to 38 V operating input voltage
- Primary output voltage regulation/no optocoupler required
- 1.9 A typical sink peak primary current capability
- Peak current mode architecture in forced PWM operation
- 300 ns blanking time
- 8 μ A IQ-SHTDWN
- Adjustable f_{SW} and synchronization
- Embedded primary output voltage supervisor
- Adjustable soft-start time
- Internal primary current limiting
- Overvoltage protection
- $R_{DS(on) HS} = 180 \text{ m}\Omega$, $R_{DS(on) LS} = 150 \text{ m}\Omega$
- Thermal shutdown

Description

The **STEVAL-L6986IV1** evaluation board is based on **L6986I** 38 V, 5 W synchronous step-down switching regulator designed for isolated buck topology.

The primary output voltage can be accurately adjusted, whereas the isolated secondary output is generated by using a transformer. No optocoupler is required.

The primary sink capability (typ. 1.9 A) allows proper energy transfer to the secondary side as well as a tracked soft-start of the secondary output. The control loop is based on a peak current mode architecture and the device operates in forced PWM.

The 300 ns blanking time filters oscillations generated by the transformer leakage inductance, making the solution more robust. Pulse by pulse current sensing on both power elements implements an effective constant current protection on the primary side. Thanks to the primary reverse current limit, the secondary output is protected against short-circuit.

The secondary voltage is stabilized over current by using a power transistor and a shunt voltage reference (**TL431AIL3T**).

The **STEVAL-L6986IV1** evaluation board generates two isolated voltages (positive around 18 V and negative between 4 and 5 V), particularly suitable for supplying the IGBT/SiC MOSFET gate driver for multiple applications. A simple by-pass enables the supply of a single isolated voltage.

Product summary	
38 V, 5 W synchronous iso-buck converter evaluation board with dual isolated output based on the L6986I	STEVAL-L6986IV1
38 V, 5 W synchronous step-down switching regulator	L6986I
Adjustable micro power shunt voltage reference	TL431AIL3T
Applications	Buck Converters Industrial Tools Metering

1 Evaluation board - isolated voltage adjustment

In case different isolated voltage values are required, a simple voltage adjustment is possible.

1.1 Positive voltage adjustment

If different isolated voltage values are required, the positive voltage can be adjusted by changing the resistor divider composed of R12 and R13 according to the following equation:

$$V_{ISO+} = 2.49 \frac{R_{12} + R_{13}}{R_{13}}$$

1.2 Negative voltage adjustment

The negative voltage can be changed by replacing D3 with a Zener diode suitable for the application requirement.

1.3 Single isolated output

A single voltage can be provided at the isolated output by removing D3 and replacing C12 with a 0 Ω resistor.

Note: For any of the above mentioned variations, a fine tuning of R11 value might be necessary.

2 Schematic diagram

Figure 1. STEVAL-L6986IV1 circuit schematic

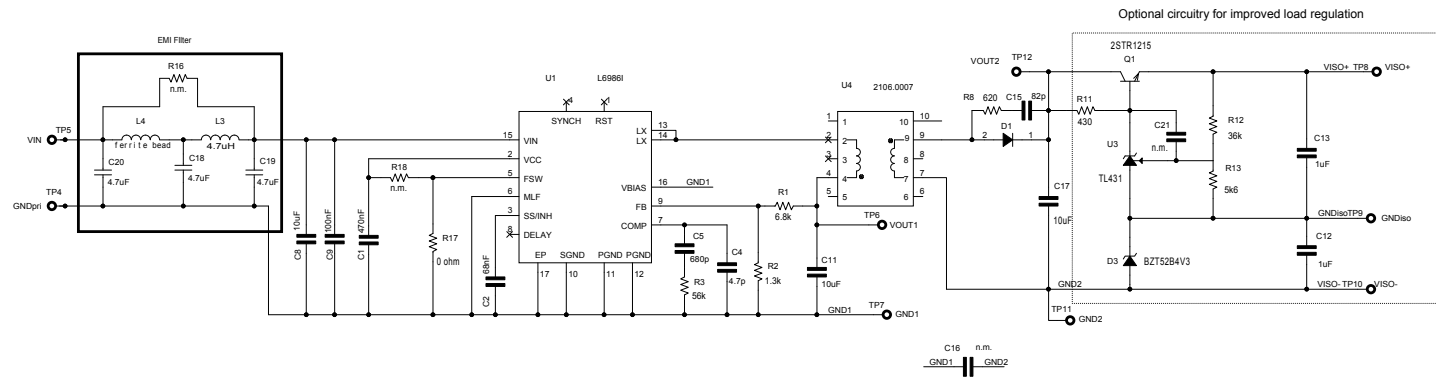

Note: The evaluation board embeds an input EMI filter (on the bottom side). If the filter is not necessary or needs to be bypassed for any test, a 0 Ω resistor can be placed on R16 (bottom side).

Revision history

Table 1. Document revision history

Date	Version	Changes
16-Jul-2021	1	Initial release.