

Quad high performance LDO evaluation board based on LDBL20, LDLN025, LD39130S and STLQ020

Data brief

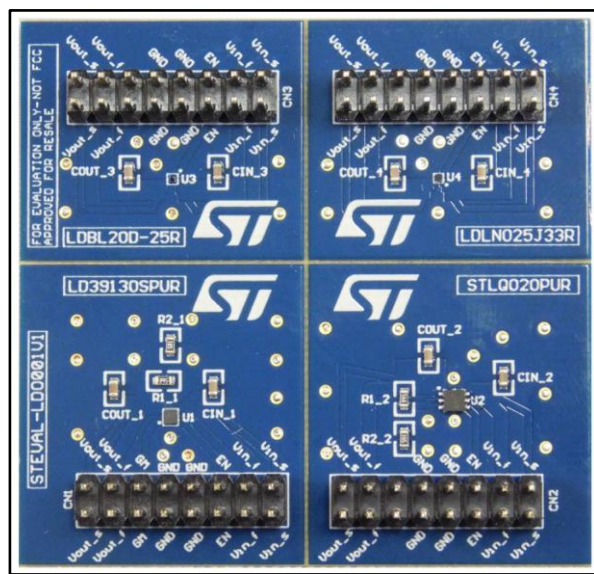

Features

- Multi LDO evaluation board based on four high performance low dropout linear voltage regulators in miniature packages
- Key features:
 - Low operating input voltage (from 1.4 V to 5.5 V)
 - Current capability from 200 mA to 300 mA
 - Low dropout (down to 160 mV typ.)
 - Ultra-low quiescent current (down to 500 nA typ.)
 - Low noise (down to 6.5 μ VRMS typ.)
 - High PSSR (up to 80 dB)
 - Logic controlled electronic shutdown (enable)
 - Tiny packages (DFN-6L, Flip-chip, ST STAMP™)
- RoHS compliant

Applications

- Wearable devices
- IoT
- Battery operated devices
- Smart phones
- Smart watches
- Fit bands
- Smart textile
- Wireless sensor networks

Description

The STEVAL-LDO001V1 board features the following high performance low dropout linear voltage regulators in miniature packages:

- LDBL20 200 mA high PSSR low quiescent current in ST STAMP™ bumpless chip-scale package
- LDLN025 250 mA low noise, low quiescent current in Flip-Chip4
- LD39130S 300 mA ultra-low quiescent current in DFN6L
- STLQ020 200 mA very-low quiescent current in DFN6L

Using the quad LDO board with state-of-the-art very low dropout voltage regulators, you can easily evaluate performance levels in a single set-up to choose the best design solution.

The four miniaturized LDOs are designed for extend battery life in portable smart devices.

1 Key parameters

Summary table with key parameters:

Table 1: Table with key parameters

Part Number	Vout version	Vout	Iout	Package	Key features
LDBL20D-25R	Fixed	2.5	200	STSTAMP™ 0.47 x 0.47 mm ²	Tiny Package; High PSRR (80 dB @ 1 kHz, 50 db @ 100 kHz typ)
LDLN025J33R	Fixed	3.3	250	Flip-Chip4	Low Noise 6.5 µVRMS typ High PSRR 80 dB @ 1 kHz typ
LD39130SPUR	Adjustable	3.3	300	DFN6L 1.2 x 1.3 mm	Very low quiescent current: 1 µA in automatic green mode; Output voltage tolerance: ± 1.0 % at 25 °C
STLQ020PUR	Adjustable	3.3	200	DFN6L 2 x 2 mm	Ultra-low quiescent current: 400 nA at no load

Key product features:

- LDBL20
 - Input voltage from 1.5 to 5.5 V
 - Ultra-low dropout voltage (200 mV typ. at 200 mA load)
 - Very low quiescent current: 20 µA typ. at no-load, 0.03 µA typ. in off mode
 - Output voltage tolerance: ±1.5 % @ 25 °C
 - 200 mA guaranteed output current
 - High PSRR (80 dB @ 1 kHz, 50 db @ 100 kHz)
 - Wide range of output voltages available on request: from 0.8 V up to 5.0 V in 50 mV step
 - Logic-controlled electronic shutdown
 - Internal soft-start
 - Optional output voltage discharge feature
 - Compatible with ceramic capacitor (COUT = 0.47 µF)
 - Internal constant current and thermal protections
 - Available in STSTAMP™ (0.47 x 0.47 mm²) package
 - Operating temperature range: -40 °C to 125 °C
- LDLN025
 - Ultra-low output noise: 6.5 µVrms
 - Operating input voltage range: 1.5 V to 5.5 V
 - Output current up to 250 mA
 - Very low quiescent current: 12 µA at no-load
 - Controlled Iq in dropout condition
 - Very low-dropout voltage: 250 mV at 250 mA
 - Very high PSRR: 80 dB @ 100 Hz, 60 dB @ 100 kHz
 - Output voltage accuracy: 2% across line, load and temperature
 - Output voltage versions: from 1 V to 5 V, with 50 mV step
 - Logic-controlled electronic shutdown
 - Output discharge feature
 - Internal soft-start
 - Overcurrent and thermal protections
 - Temperature range: from -40 °C to +125 °C

- LD39130S
 - Input voltage from 1.4 V to 5.5 V
 - Ultra-low dropout voltage (300 mV typ. at 300 mA load)
 - Automatic green mode
 - Very low quiescent current: 1 μ A in green mode, 45 μ A in normal mode and 0.1 μ A typ. in off mode
 - Output voltage tolerance: ± 1.0 % at 25 $^{\circ}$ C
 - 300 mA guaranteed output current
 - Wide range of output voltages available on request: adjustable from 0.8 V, fixed up to 4.0 V in 100 mV step
 - Logic-controlled electronic shutdown
 - Internal soft-start
 - Compatible with ceramic capacitor (COUT = 330 nF)
 - Internal current foldback and thermal protections
 - Available in DFN6L 1.2 x 1.3 mm and Flip-chip 4 bumps 0.69 x 0.69 mm. 0.4 pitch
 - Operating temperature range: -40 $^{\circ}$ C to 125 $^{\circ}$ C

- STLQ020 (under development)
 - Operating input voltage range: 2 V to 5.5 V
 - Output current up to 200 mA
 - Ultra-low quiescent current: 400 nA at no load; 100 μ A at 200 mA load
 - Controlled Iq in dropout condition
 - Very low dropout voltage: 160 mV at 200 mA
 - Output voltage accuracy: 2% at room temp.; 3% in full temp. range
 - Output voltage versions: from 0.8 V to 4.5 V, with 50 mV step and adjustable
 - Logic-controlled electronic shutdown
 - Output discharge feature (optional)
 - Internal overcurrent and thermal protections
 - Temperature range: from -40 $^{\circ}$ C to +125 $^{\circ}$ C
 - Packages: DFN6 - 2 x 2 mm, SOT323-5L, Flipchip4 0.8 x 0.8 mm, STSTAMP™

2 Schematic diagram

Figure 1: STEVAL-LDO001V1 circuit schematic

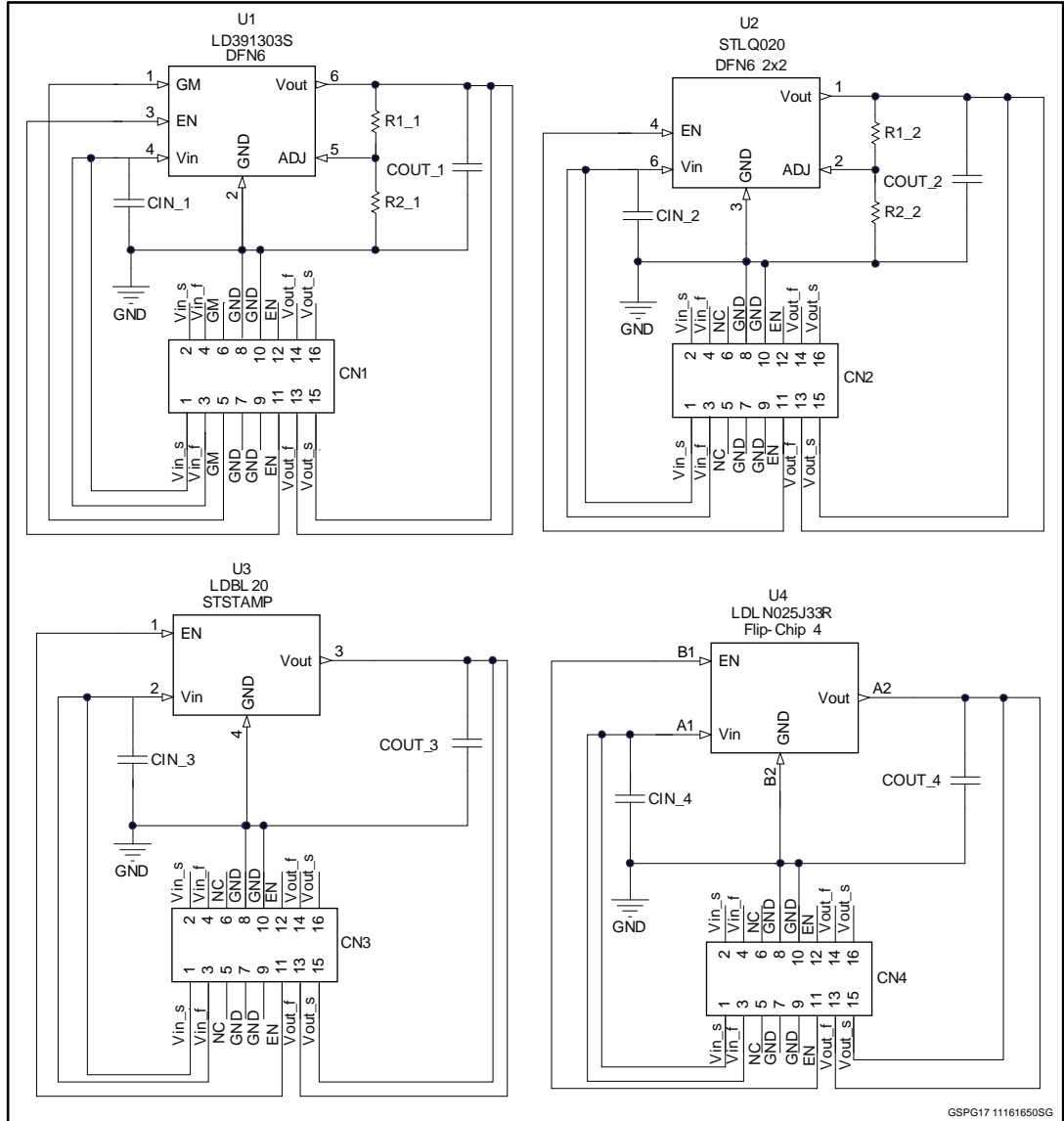

3 Pin and connector configuration

Table 2: Connector_1 pinout (CN1)

U1 Pin	4_Vin	4_Vin	1_GM	2_GND	2_GND	3_EN	6_Vout	6_Vout
CN1 upper strip	2_Vin_s	4_Vin_f	6_GM	8_GND	10_GND	12_EN	14_Vout_f	16_Vout_s
CN1 down strip	1_Vin_s	3_Vin_f	5_GM	7_GND	9_GND	11_EN	13_Vout_f	15_Vout_s

Table 3: Connector_2 pinout (CN2)

U2 Pin	6_Vin	6_Vin		3_GND	3_GND	4_EN	1_Vout	1_Vout
CN2 upper strip	2_Vin_s	4_Vin_f	6_NC	8_GND	10_GND	12_EN	14_Vout_f	16_Vout_s
CN2 down strip	1_Vin_s	3_Vin_f	5_NC	7_GND	9_GND	11_EN	13_Vout_f	15_Vout_s

Table 4: Connector_3 pinout (CN3)

U3 Pin	2_Vin	2_Vin		4_GND	4_GND	1_EN	3_Vout	3_Vout
CN3 upper strip	2_Vin_s	4_Vin_f	6_NC	8_GND	10_GND	12_EN	14_Vout_f	16_Vout_s
CN3 down strip	1_Vin_s	3_Vin_f	5_NC	7_GND	9_GND	11_EN	13_Vout_f	15_Vout_s

Table 5: Connector_4 pinout (CN4)

U4 Pin	A1_Vin	A1_Vin		B2_GND	B2_GND	B1_EN	A2_Vout	A2_Vout
CN4 upper strip	2_Vin_s	4_Vin_f	6_NC	8_GND	10_GND	12_EN	14_Vout_f	16_Vout_s
CN4 down strip	1_Vin_s	3_Vin_f	5_NC	7_GND	9_GND	11_EN	13_Vout_f	15_Vout_s

4 Revision history

Table 6: Document revision history

Date	Version	Changes
01-Mar-2017	1	Initial release.