

7.5 W non-isolated constant current LED driver based on VIPer0P

Data brief

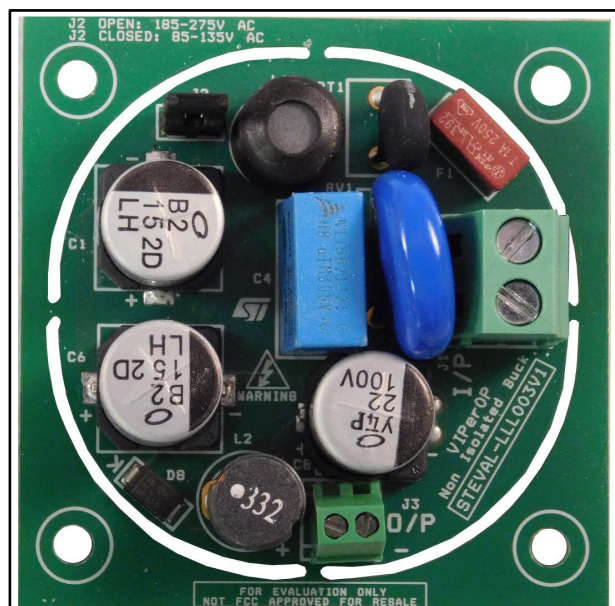

Description

The STEVAL-LLL003V1 evaluation board is a constant current LED driver, based on non-isolated buck topology using VIPer0P.

The board delivers 130 mA \pm 2.5% at an output load of 15 – 21 white LEDs.

The buck topology ensures a minimum number of components as well as higher efficiency when operating at high output voltage (60 V and above).

The application core is the new VIPer0P offline high voltage converter which smartly integrates an 800 V avalanche rugged power MOSFET with current-mode control.

Thanks to the embedded E/A (EAGND) floating GND, the direct current regulation can be applied to the buck converter, improving the LED current accuracy.

Features

- Non-isolated buck topology
- Two input voltage ranges:
 - US range: 85-135 V_{AC} (jumper J2 - closed, voltage doubler)
 - EU range: 175-285 V_{AC} (jumper J2 - open, bridge rectifier)
- 130 mA \pm 2.5% output constant current (15-21 white LEDs connected)
- 60 kHz fixed frequency operation
- \cong 89% efficiency at maximum load
- Protections:
 - open/no-load circuit protection
 - short/overload circuit protection
 - thermal shutdown
- Soft start for improved system reliability
- Meets IEC55022 Class B conducted EMI even with reduced EMI filter, thanks to the frequency jittering feature
- Meets IEC61000-4-2(ESD), IEC61000-4-4 (Burst) and IEC61000-4-5 (Surge)
- RoHS compliant

Schematic diagram

Figure 1: STEVAL-LLL003V1 circuit schematic

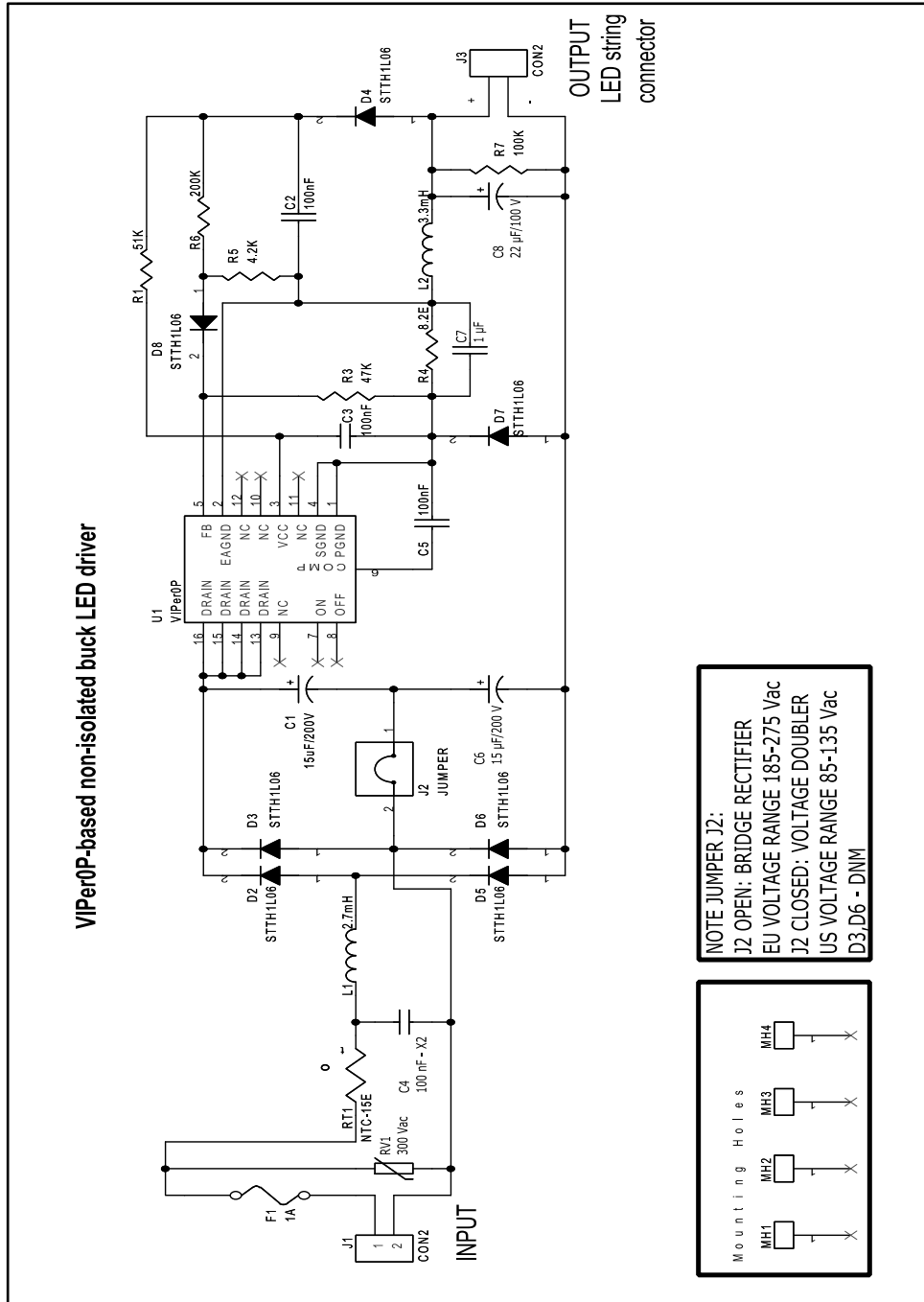

Revision history

Table 1: Document revision history

Date	Version	Changes
04-Sep-2017	1	First release.