

100 W high efficiency and low THD dimmable LED driver reference design based on HVLED001B, HVLED002 and SPSGRFC



Features

- Input voltage range 90 – 265 V_{AC}
- Dual stage power converter: high power factor PSR-CV and CC step-down
- Sub-1 GHz connectivity for 6LoWPAN Mesh network
- Output voltage range 40 - 70 V, max. current 1.4 A with less than 100 mA current ripple, max. output power 100 W.
- Peak efficiency overall:
 - Min: above 90% at 90 V_{IN AC}, 40 V_{OUT DC}
 - Max: above 93% at 265 V_{IN AC}, 70 V_{OUT DC}
- Standby power consumption:
 - 265 V_{IN AC} without control board: less than 0.3 W
 - 265 V_{IN AC} with control board: less than 0.6 W
- RoHS compliant

Description

The STEVAL-LLL008V1 reference design is a dual-stage LED driver with high power factor designed for 100 W LED lighting applications using 6LoWPAN Mesh networking.

The front-end flyback converter provides high power factor and low THD and implements CV primary side regulation (PSR) with input from an auxiliary winding on the transformer through the ZCD pin on the HVLED001B controller, so no isolated optocoupler is required. The flyback converter can deliver 105 W with an average 79 V output voltage and 1.8 V maximum ripple.

The converter output supplies an inverse buck stage that delivers a regulated 1.4 A current to the LED driver load. The secondary transformer is also able to supply (a few milliamps via an auxiliary choke) the voltage needed to power up the HVLED002 controller, which manages the inverse buck circuit to provide current limitation for dimming and On/Off control.

The STEVAL-LLL008V1 integrates an STM32L071KZ microcontroller, which is able to receive remote on, off and dimming commands via an embedded SPSGRFC sub-1 GHz transceiver module. The connectivity functionality can be extended to multiple lighting nodes in a 6LoWPAN mesh network.

A data concentrator unit (DCU) and mobile Android application have been developed to help you explore the LED lighting reference design further. The DCU consists of a NUCLEO-F401RE development platform, plus the X-NUCLEO-IDS01A4 for sub 1-GHz communication with the LED driver board and a X-NUCLEO-IDB05A2 board for Bluetooth communication with a mobile device.

The ST 6LoWPAN Smart Streetlight mobile application (available on Google Play store) collects lighting nodes represented by the microcontroller and RF module on the evaluation board in a 6LoWPAN mesh network.

Product summary	
Dual stage LED driver evaluation board with High Power Factor	STEVAL-LLL008V1
Firmware for STEVAL-LLL008V1 evaluation kit	STSW-LLL008FW
HPF flyback controller with constant voltage primary-sensing and ultra-low standby consumption	HVLED001B
high performance current mode LED controller	HVLED002
ultra-low-power ARM Cortex-M0+ MCU	STM32L071KZ
N-channel 800 V, 0.23 Ω typ., 16 A MDmesh K5 Power MOSFET in TO-220FP package	STF23N80K5
N-channel 100 V, 0.062 Ω typ., 4.5 A STripFET F7 Power MOSFET in a PowerFLAT 3.3x3.3 package	STL4N10F7

Product summary	
sub-1 GHz programmable transceiver module	SPSGRFC
Applications	LED Street Lighting

1 LED street lighting in Smart City applications

High voltage LED street and zone lighting applications typically require robust but highly efficient power supplies able to generate tightly regulated output currents with high power factor, low THD and minimal voltage ripple.

The design achieves very high efficiency through the HVLED001B controller, which drives a STF23N80K5 power MOSFET on the primary side of an AC/DC HPF flyback converter and regulates the voltage on the same primary side.

The flyback converter output is then regulated by the inverse buck stage, which is driven by the HVLED002 controller through the STL4N10F7 power MOSFET. The HVLED002 translates external dimming commands into current limitation on the inverse buck converter to achieve the desired dimming effect.

Networking and connectivity solutions are also often implemented for the simultaneous control of several lighting nodes in a certain area. The STEVAL-LLL008V1 power converter is coupled with a SPSGRFC module to provide sub-1 GHz connectivity for remote dimming and on/off control. The STSW-LLL008FW firmware for the evaluation kit provides 6LoWPAN functionality to allow wireless mesh network control of multiple nodes, with the addition of a data concentrator unit able to provision devices on a 6LoWPAN network and interface with an app to deliver Smart City lighting control.

Figure 1. LED street lighting application with high voltage LED controller

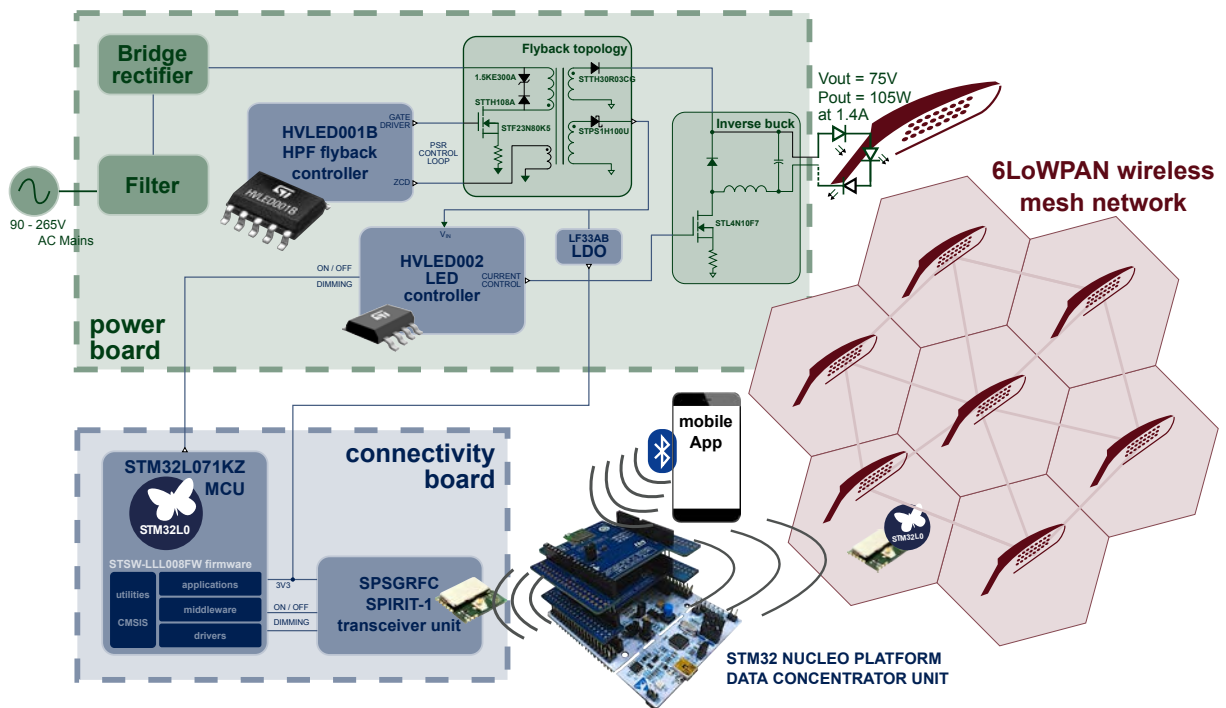

RELATED LINKS

[STM32Cube function pack for IoT sensor node connection to 6LoWPAN networks through sub-1GHz RF communication](#)

2 Schematic diagrams

Figure 2. STEVAL-LLL008V1 power board schematic diagram

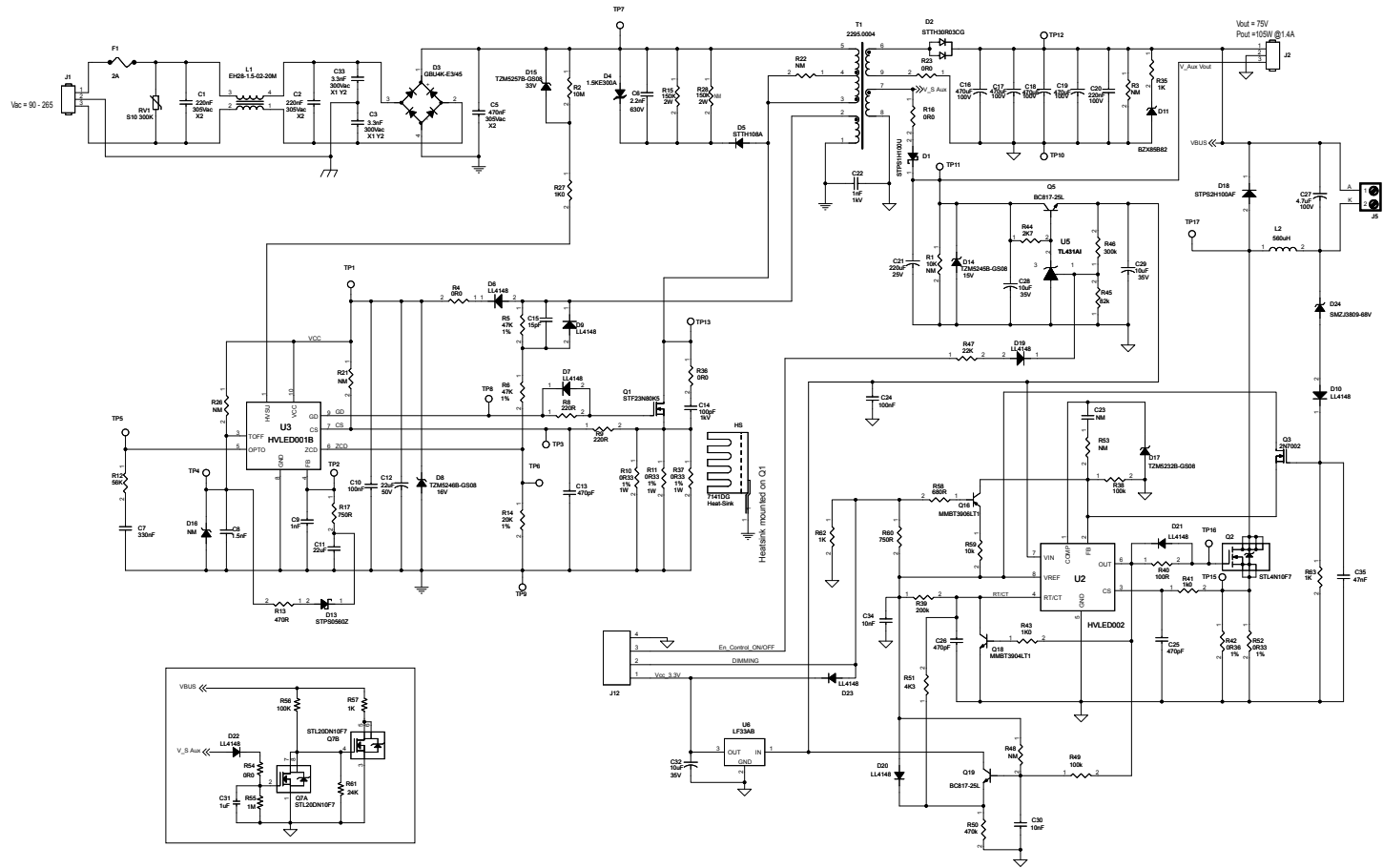
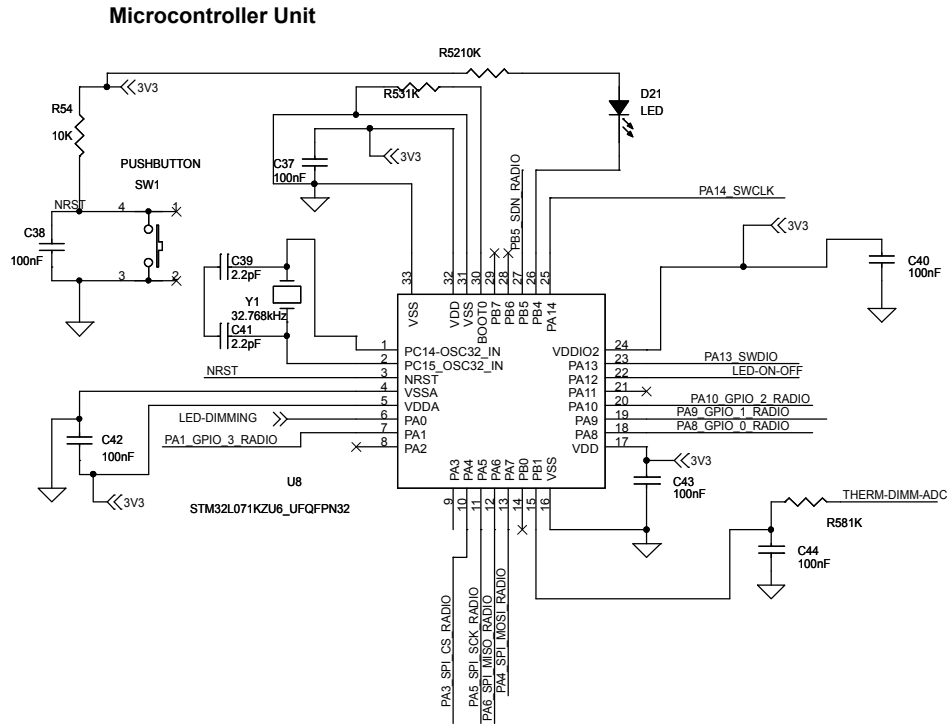
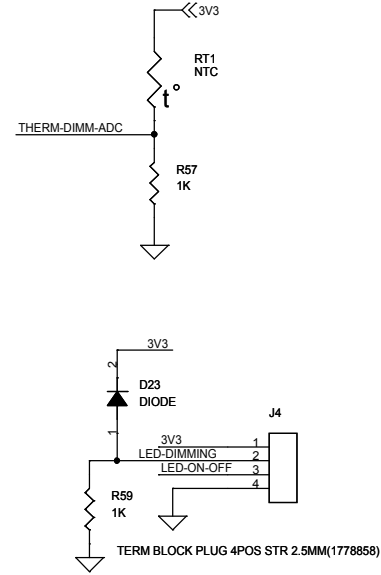

Figure 3. STEVAL-LLL008V1 control board schematic diagram



Thermal Foldback



SPIRIT-1 Transceiver Unit

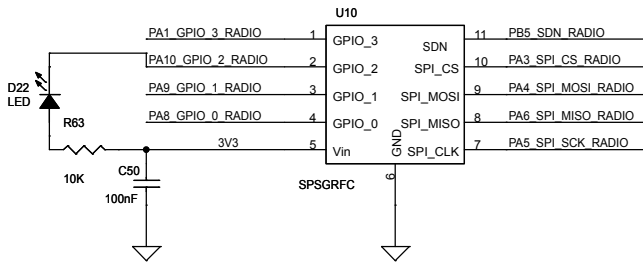

Programming Connector

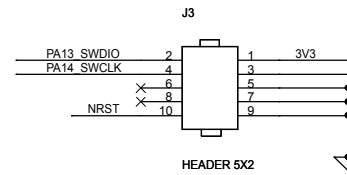

Revision history

Table 1. Document revision history

Date	Version	Changes
04-Mar-2020	1	Initial release.
06-May-2020	2	Substituted X-NUCLEO-IDB05A1 (no longer recommended for new designs) with X-NUCLEO-IDB05A2