

## 300 W very high AC input voltage LED driver with digital power control



### Features

- System architecture based on transition mode boost PFC, half bridge LCC and synchronous rectification (full bridge)
- 270-480 V<sub>AC</sub> input voltage range
- Output can be configured in constant current (CC) or constant voltage (CV) mode:
  - 300 W maximum O/P power rating
  - CV mode: 48.5 V ± 1%
  - CC mode: 6.25 A ± 2.5% with voltage drop from 36 to 48 V
- Peak efficiency >93.5%
- Power Factor > 0.9 for load > 33% of max. load of the input voltage range
- THD < 20% for load > 25% of max. load of the input voltage range
- Dimming control in CC mode configuration:
  - 0-10 V control
  - 1% resolution
  - analog dimming
- Soft start
- Protections: I/P and O/P under and overvoltage protection, O/P open/no load circuit protection, O/P short/overload circuit protection
- Digitally controlled by [STM32F334R8](#)
- RoHS compliant
- WEEE compliant (2012/19/UE RAEE II)

Product summary	
300 W output digitally controlled HV AC Input HB LED driver	<a href="#">STEVAL-LLL009V1</a>
Firmware for STEVAL-LLL009V1 based on STM32F334R8 MCU	<a href="#">STSW-LLL009FW</a>
Mainstream mixed signal MCU ARM Cortex-M4 core with DSP and FPU	<a href="#">STM32F334R8</a>
Galvanically isolated 4 A half-bridge dual channel gate driver	<a href="#">STGAP2D</a>
N-channel 950 V, 0.275 Ohm typ., 17.5 A MDmesh DK5 Power MOSFET in TO-247 package	<a href="#">STW20N95DK5</a>
N-channel 950 V, 0.275 Ohm typ., 17.5 A MDmesh K5 Power MOSFET	<a href="#">STW20N95K5</a>
N-channel 100 V, 0.0068 Ohm typ., 80 A STripFET F7 Power MOSFET in TO-220 package	<a href="#">STP100N10F7</a>
Applications	<a href="#">LED Lighting and Controls</a>

### Description

The [STEVAL-LLL009V1](#) digitally controlled 300 W power supply consists of power factor correction (PFC) and half-bridge LCC resonant converter power stages. An [STM32F334R8](#) microcontroller implements DC-DC and output synchronous rectification digital control, while the PFC is driven in transition mode by the [L6562AT](#) controller. The system supports constant voltage (CV) and constant current (CC) operation.

MDmesh K5 and MDmesh DK5 Power MOSFETs are used in the PFC and LCC half-bridge, respectively, to ensure maximum efficiency, while the STripFET F7 Power MOSFET is employed to reduce conduction losses in the synchronous rectification stage on the secondary side.

Both the primary and secondary sections are supplied by an off-line flyback circuit based on [VIPER267KDTR](#) high voltage converter for ultra-wide input which provides regulated voltages to the control board, the gate driver ICs and the signal conditioning circuits.

Formal testing and measurement results confirm the ability and performance of ST power products combined with comprehensive digital control to deliver high efficiency, power factor near unity, and low THD across wide input voltage and load conditions.

# 1 Block diagram

Figure 1. STEVAL-LLL009V1 functional block diagram

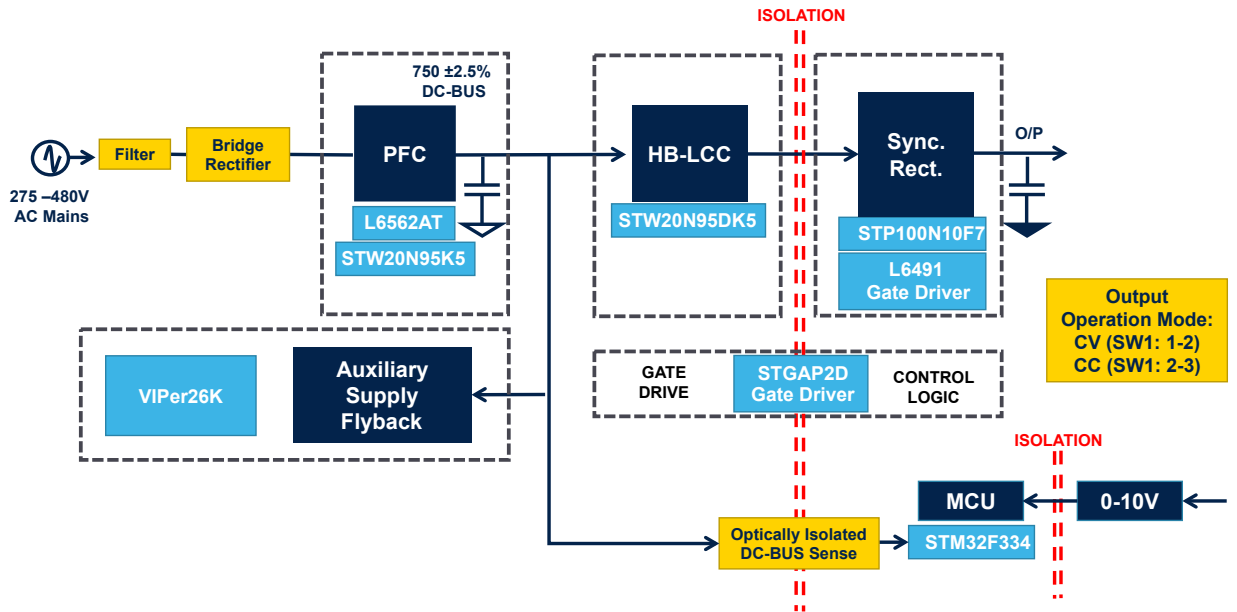



Figure 3. Power board - DC-DC converter

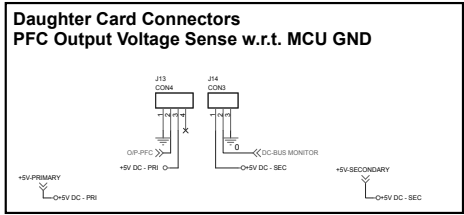
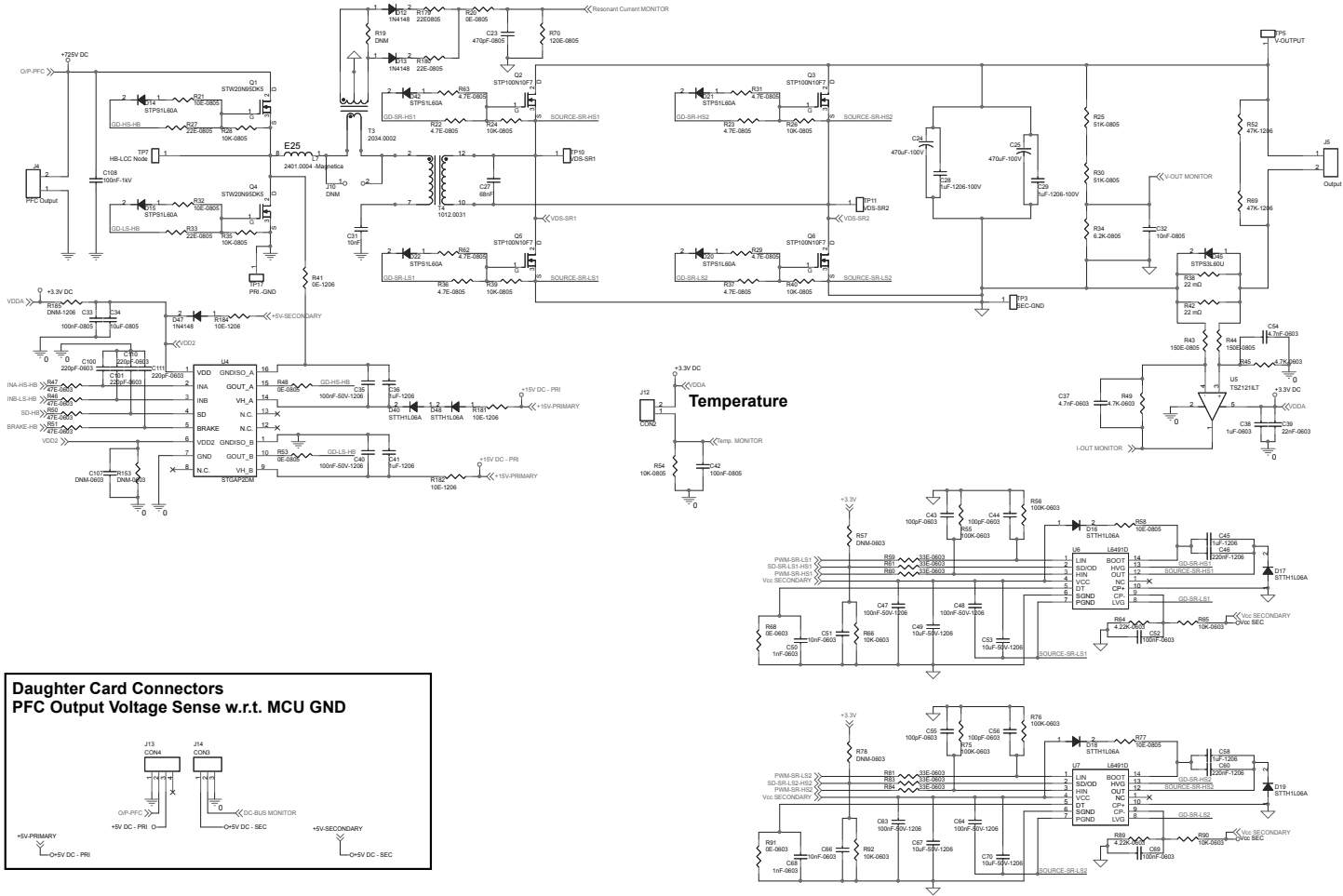

Figure 4. Power board - Aux power supply

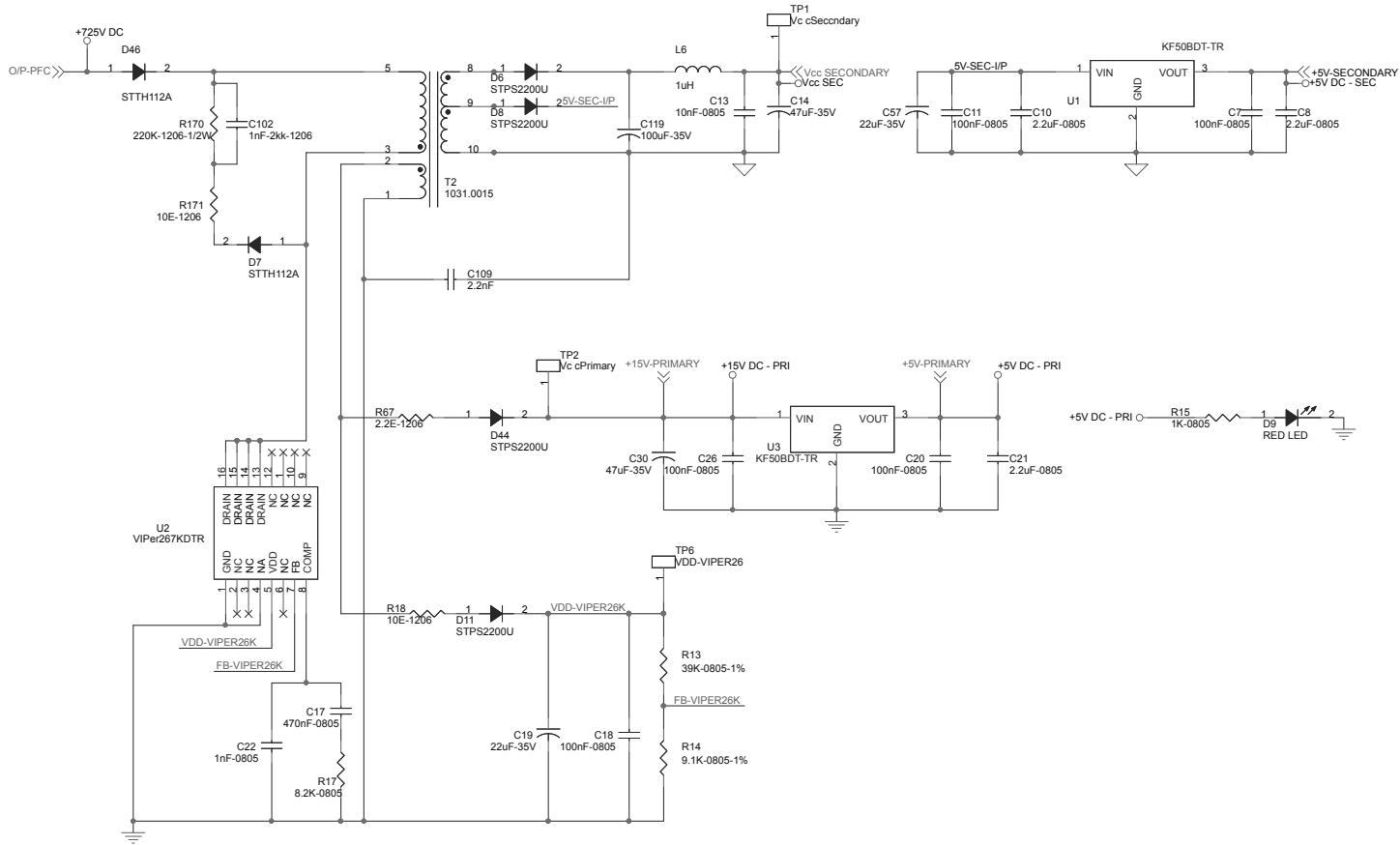
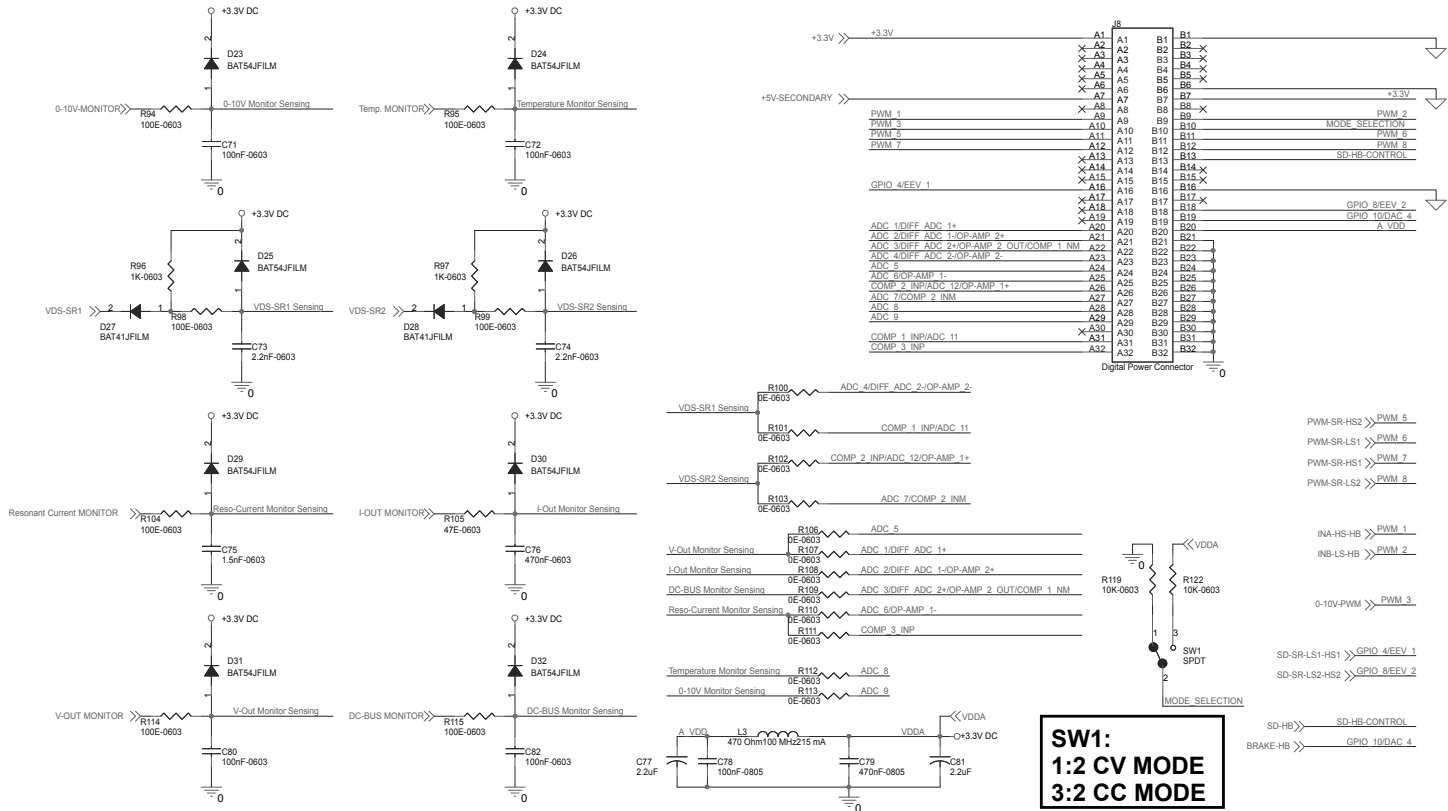

Figure 5. Power board - MCU connector



Note: The microcontroller ground is referenced to the power converter secondary side. The secondary side ground of the power converter and the ground denoted by 0 are combined on the microcontroller daughter card. The analog and control signals ground are denoted by 0 to get star ground connection and reduce switching noise interference.



Figure 6. Daughter board - PFC voltage read with isolation

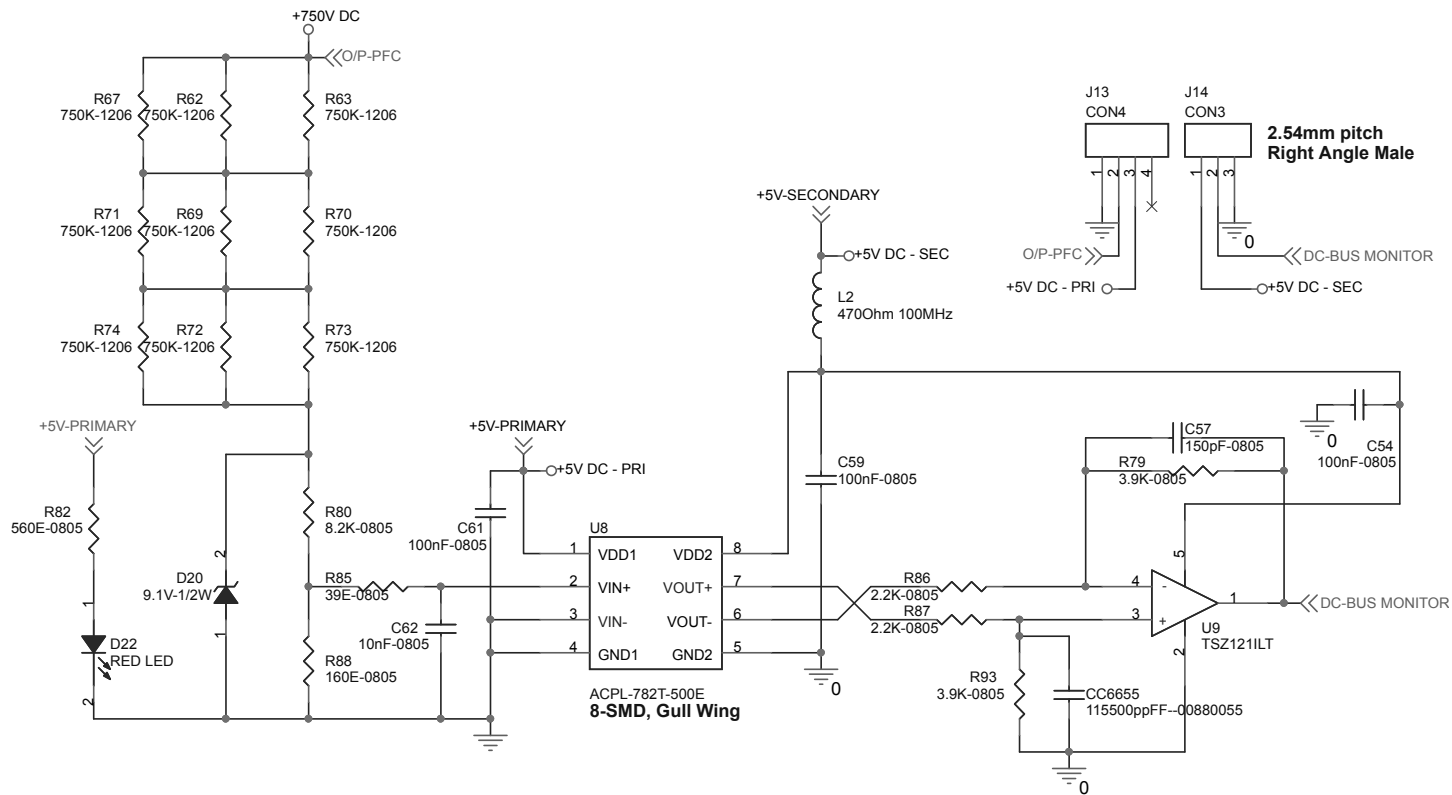
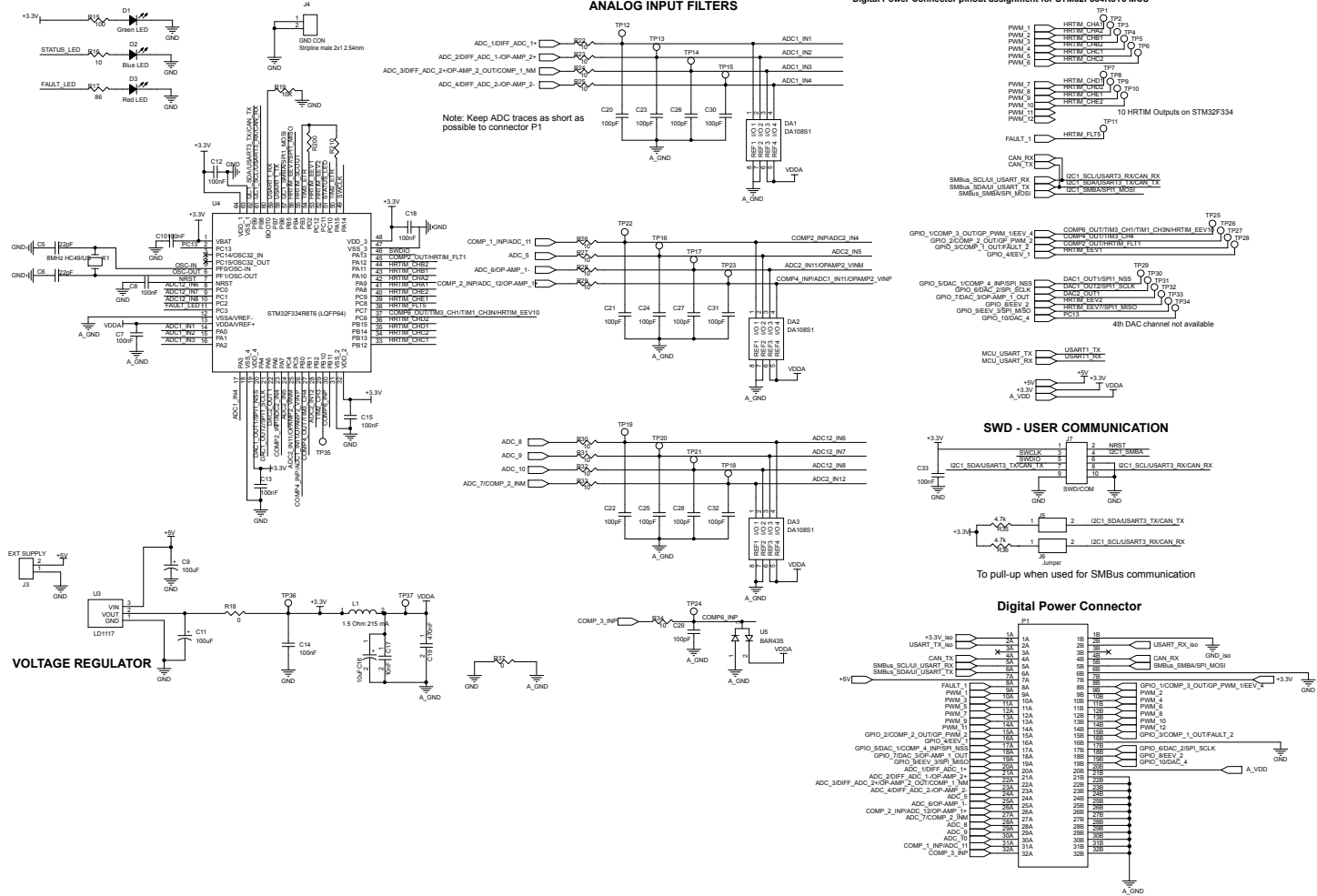

Figure 7. Control board - MCU and connector schematic



Note: The microcontroller ground is referenced to the power converter secondary side. On the microcontroller schematic, the ground symbol is denoted by GND and A\_GND (Analog Signal Ground). Different symbols have been used for better PCB layout. Both GND and A\_GND are combined on the microcontroller at R37.



Figure 8. Control board - opto-isolated communication

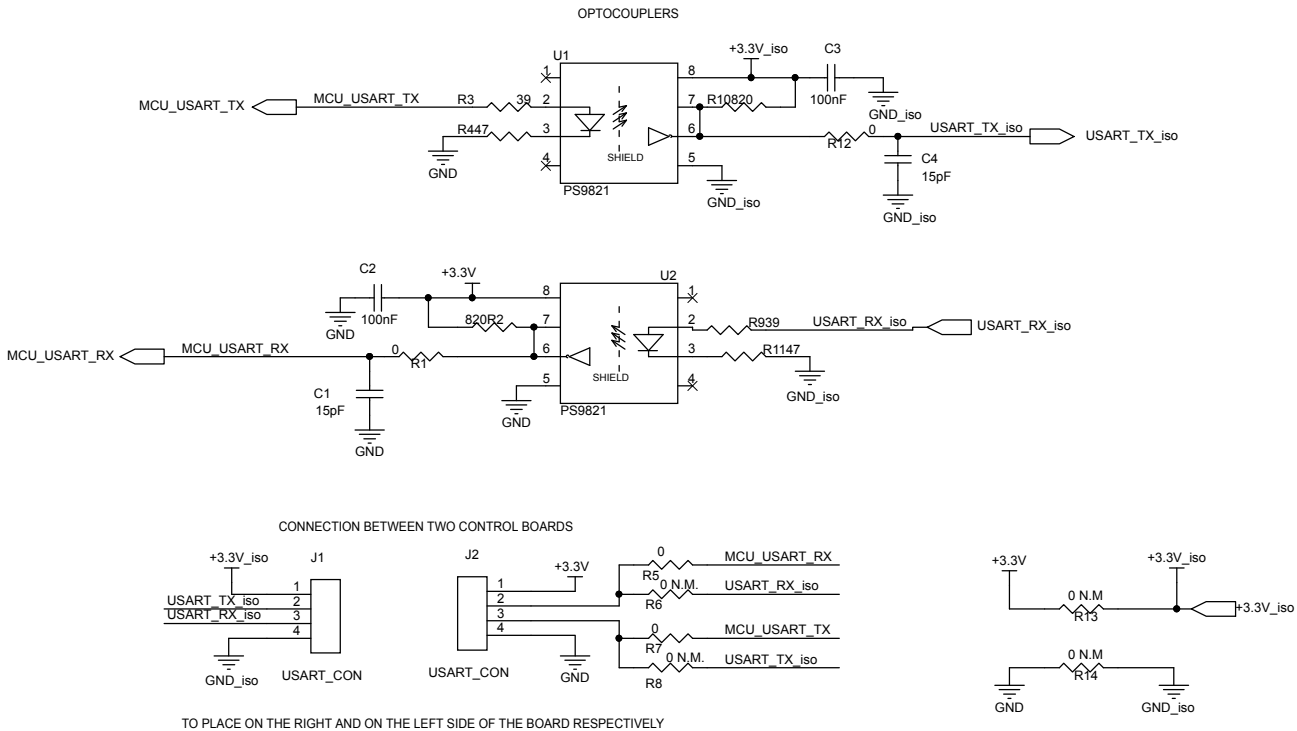
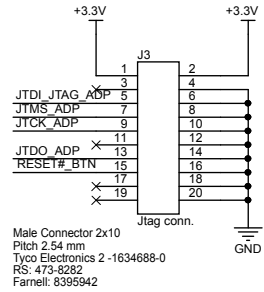
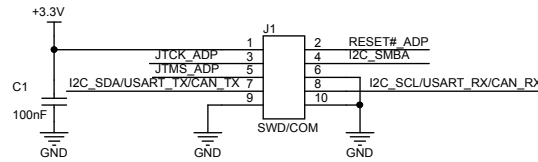

Figure 9. Adapter board

JTAG



SWD - USER COMMUNICATION



USER COMMUNICATION CONFIG

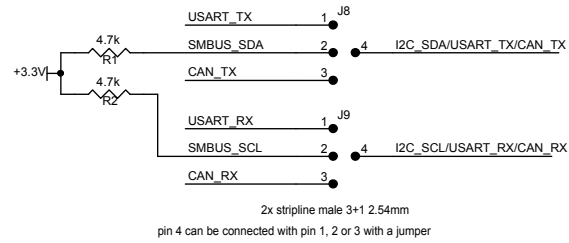

CAN

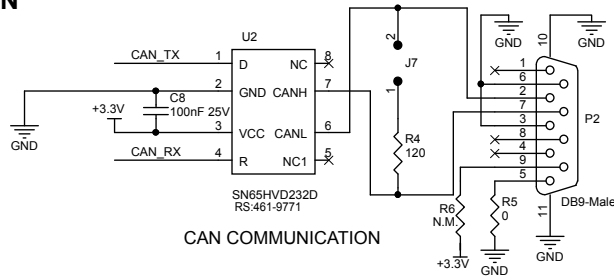

SMBUS

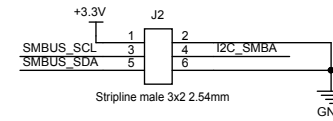

RESET BUTTON

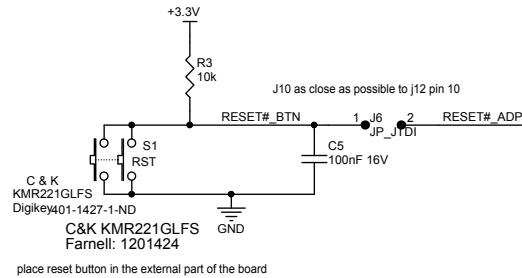

RS-232

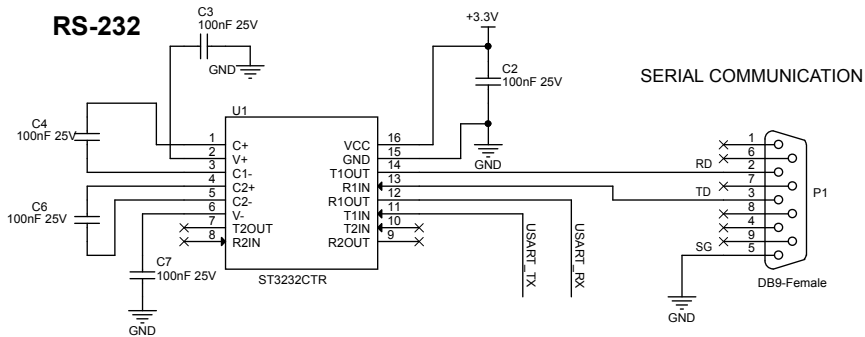

## Revision history

**Table 1. Document revision history**

Date	Version	Changes
17-Nov-2020	1	Initial release.