

## Evaluation kit for LED8102S 8-channel LED driver with direct switch control

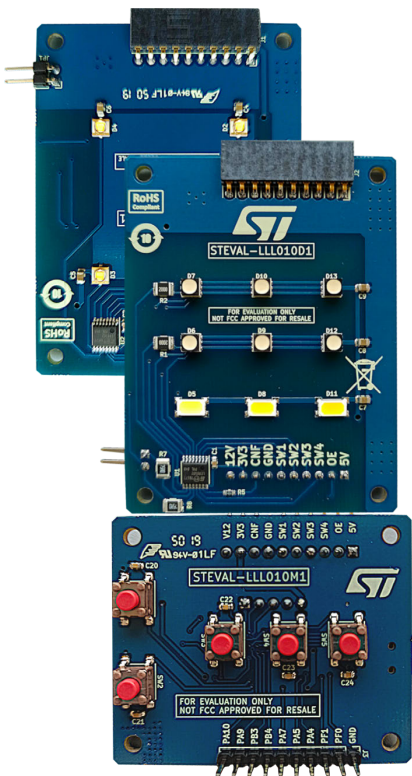

### Features

- Double-sided LED board providing choice of white LED or RGB LED operation
- Full LED color temperature control thanks to 8-channel LED8102S LED driver
- Direct push button ON/OFF and dimming control
- STM32 MCU with firmware including demonstrative LED sequences
- Dedicated PWM signal for brightness and dimming management
- CE Certified
- RoHS and China RoHS compliant
- WEEE compliant (2012/19/UE RAEE II)

### Description

The STEVAL-LLL010V1 kit consists of a two-sided LED panel board and separate control board with MCU and several user interface buttons.

Each side of the LED board has an embedded LED8102S 8-channel LED driver IC and corresponding array of four independent white LEDs on one side, and a pair of three RGB LEDs in series on the other side.

The control board mounts several switches for manual control of LED brightness and color on the white LEDs and RGB LEDs, respectively. An STM32F042 microcontroller is included to run LED control demonstration firmware to help users further evaluate the functionality of the featured LED8102S LED driver and develop custom applications.

The entire kit is powered through a USB mini connector on the control board.

#### Product summary

evaluation kit for LED8102S 8-channel LED driver with direct switch control	STEVAL-LLL010V1
8-channel LED driver with direct switch control	LED8102S
firmware for STEVAL-LLL010V1 with demonstration examples	STSW-LLL010FW
Applications	LED Lighting and Controls Human Machine Interface

# 1 LED control solution overview with LED8102S driver and STM32F042 MCU

The microcontroller has several peripherals that you can access through the J3 GPIO connector to provide additional application functionality, such as human interfaces or sensing and monitoring circuitry. You can load custom application firmware onto the MCU through the J2 SWD connector, using an appropriate programming/ debugging device such as ST-Link.

**Figure 1. Control board top and bottom**

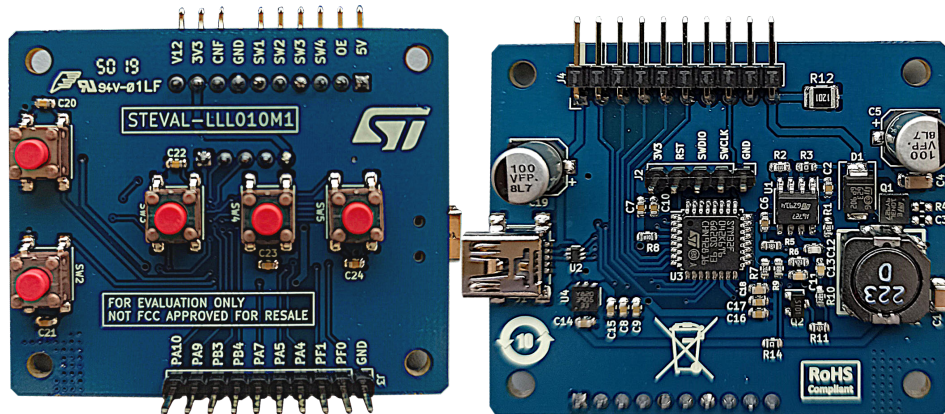

The control board has a mini USB connector to power itself and the connected LED board. Once both boards are connected and powered, the user interface buttons on the control board allow immediate manipulation of the LEDs in manual mode, or activation of the various automatic sequences available in the firmware.

**Figure 2. Control board switches**

- [PWR]: toggles LED on/off with a gradual effect
- [SEL]: cycles through individual and global selection of available LEDs or LED strings
- [UP/DOWN]: press and hold to increase and decrease selected LED brightness
- [DEMO]: cycles through demonstration sequences available in the firmware

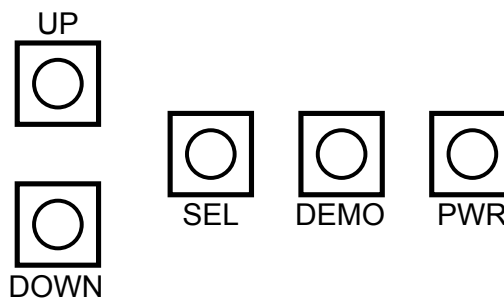

The LED board in the kit has two separate control board connectors that allow you to control the four white LEDs on one side of the board, or the two rows of RGB LEDs on the other side of the board by orienting and connecting the board appropriately.

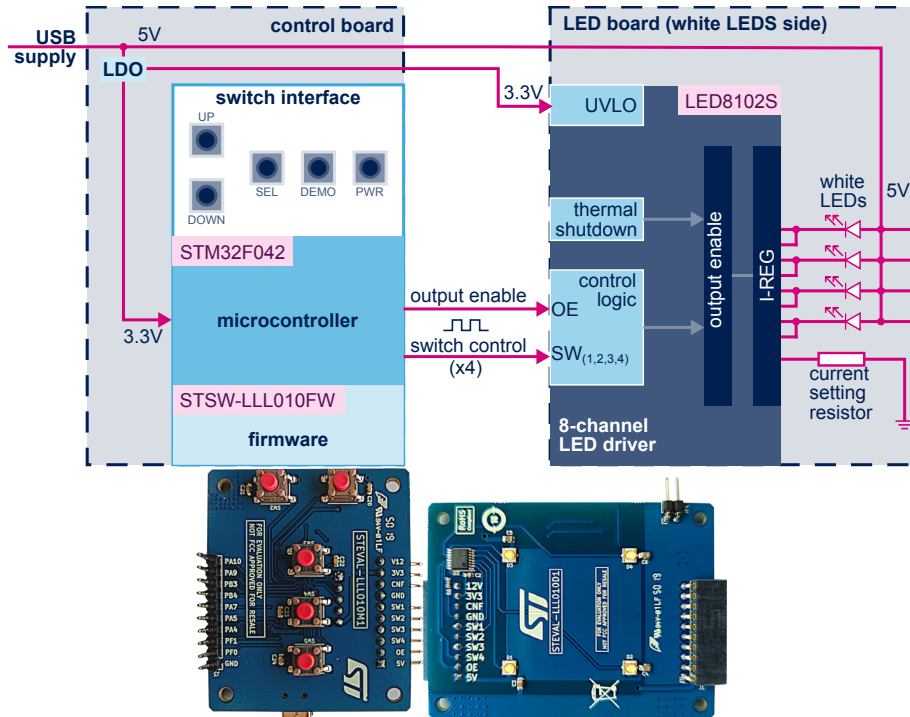
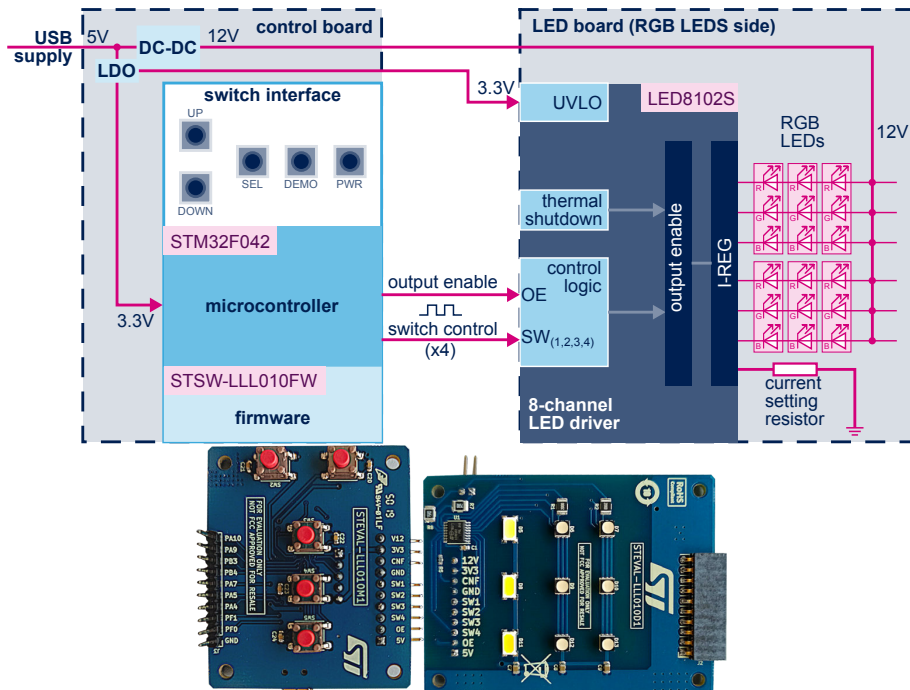
**Figure 3. LED8102S LED driver and white LED scheme**

**Figure 4. LED8102S LED driver and RGB LED scheme**

## 2 Schematic diagrams

Figure 5. STEVAL-LLL010V1 control board

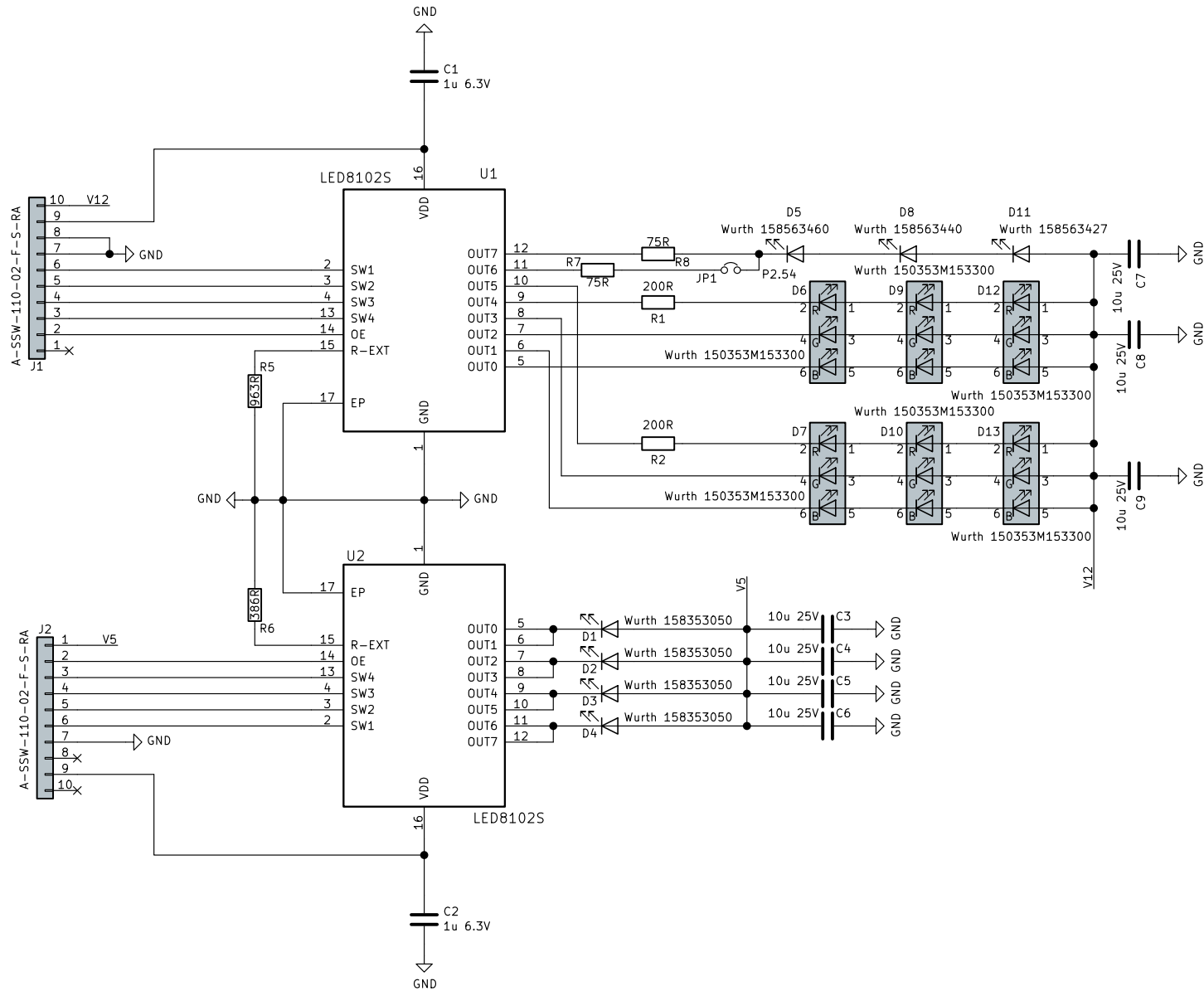
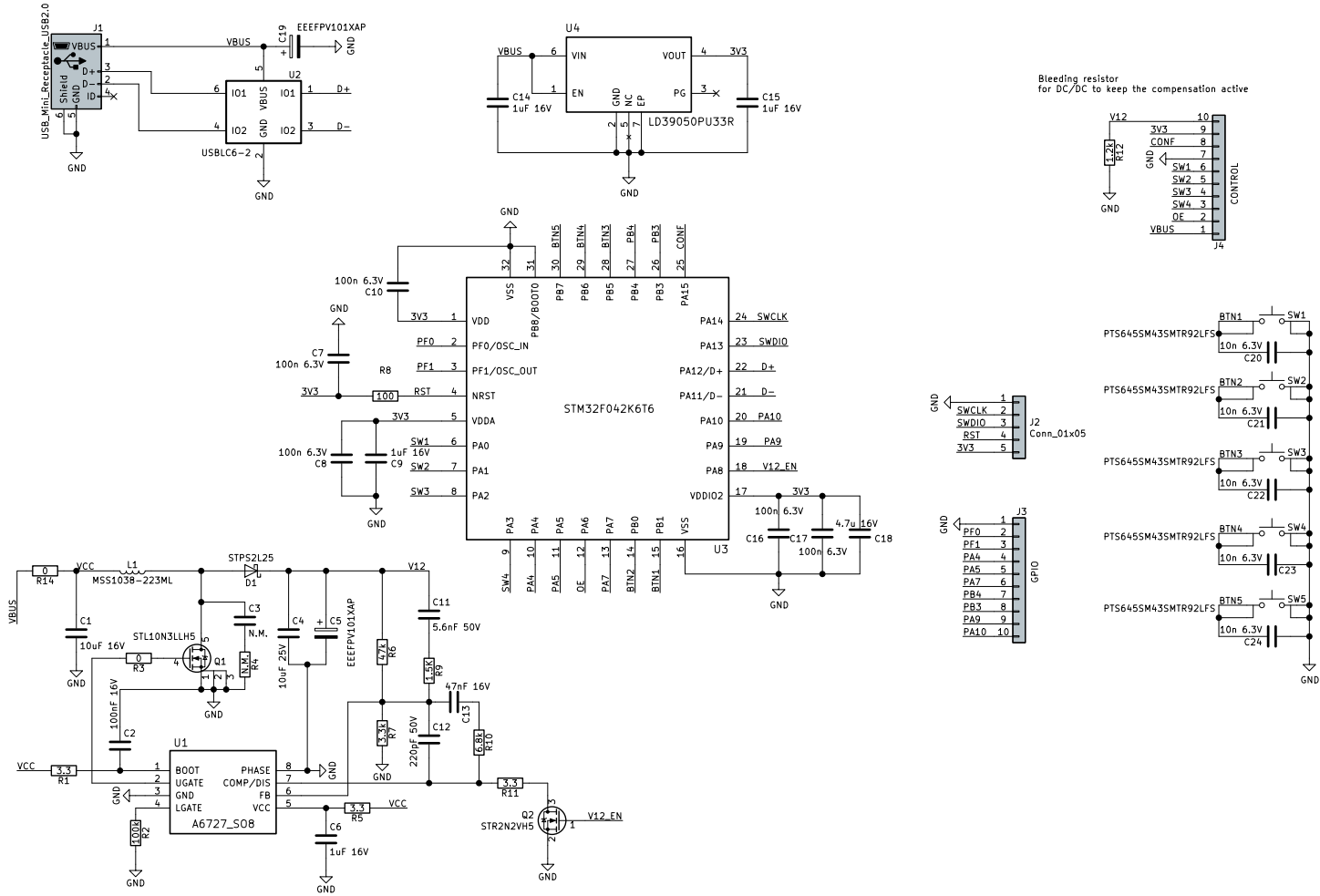

Figure 6. STEVAL-LLL010V1 LED board



## Revision history

**Table 1. Document revision history**

Date	Version	Changes
06-Jul-2020	1	Initial release.