

Power supply evaluation board for LNB based on the LNBH26S

Data brief

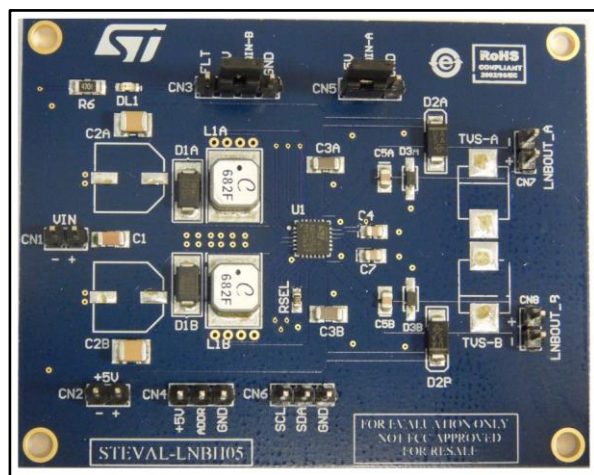

Description

This evaluation board implements a DC-DC converter based on the LNBH26S device. It is used to power LNBs inside dish antennas to receive satellite TV signals.

The LNBH26S is an integrated solution for supplying and interfacing satellite LNB modules in accordance with international standards. This simple and complete solution for dual tuner satellite receivers offers high performance at low cost and low external component count.

The LNBH26S evaluation board includes an I²C bus interface and the internal 22 kHz tone generator which is factory trimmed and can be controlled by the DSQIN pin (TTL compatible), allowing immediate DiSEqC™ data encoding.

Thanks to a fully integrated step-up DC-DC converter, it functions with a single input voltage supply source ranging from 8 V to 16 V.

Features

- Complete interface between LNB and I²C bus
- Built-in DC-DC converter for single 12 V supply operation and high efficiency (typ. 93% @ 0.5 A)
- Selectable output current limit by external resistor
- Compliant with the output voltage specifications of principal satellite receivers (15 programmable levels)
- Accurate built-in 22 kHz tone generator suits widely accepted standards
- 22 kHz tone waveform integrity guaranteed also at no load condition
- Low drop post regulator and high efficiency step-up PWM with integrated power N-MOS allowing low power losses
- LPM function (low power mode) to reduce dissipation
- Overload and overtemperature internal protection with I²C diagnostic bits
- LNB short-circuit dynamic protection
- ±4 kV ESD tolerant on output power pins
- RoHS compliant

1 Schematic diagram

Figure 1: STEVAL-LNBH05 circuit schematic

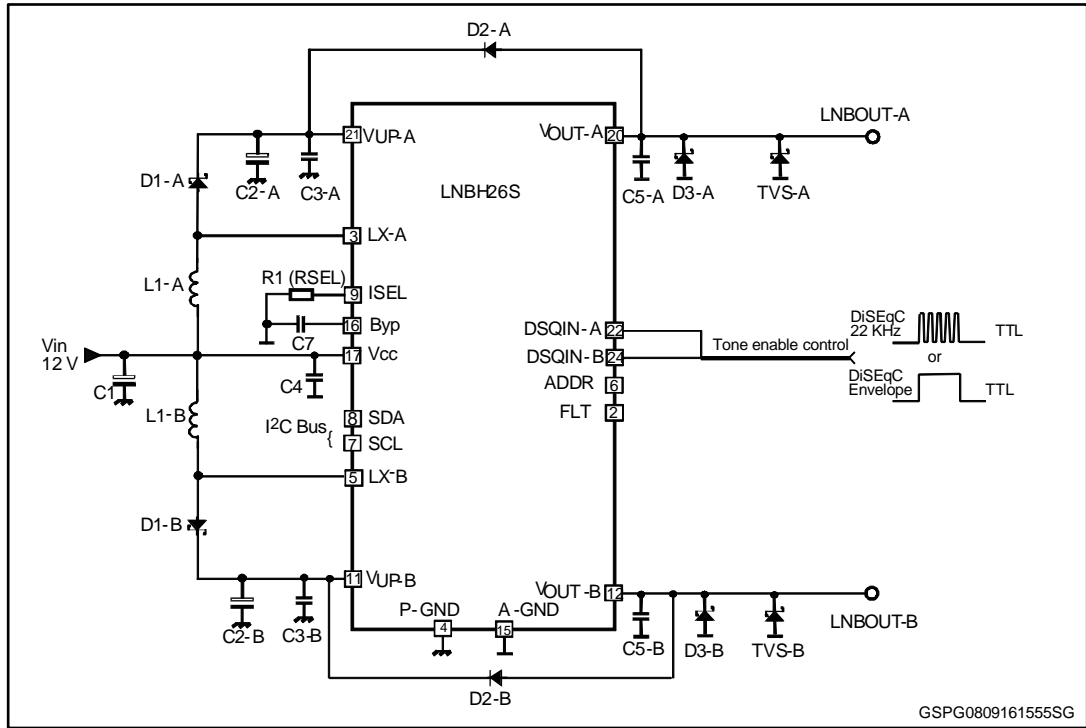

2 Revision history

Table 1: Document revision history

Date	Version	Changes
19-Sep-2016	1	Initial release.