

## Power supply evaluation board for LNB based on the LNBH26S

Data brief

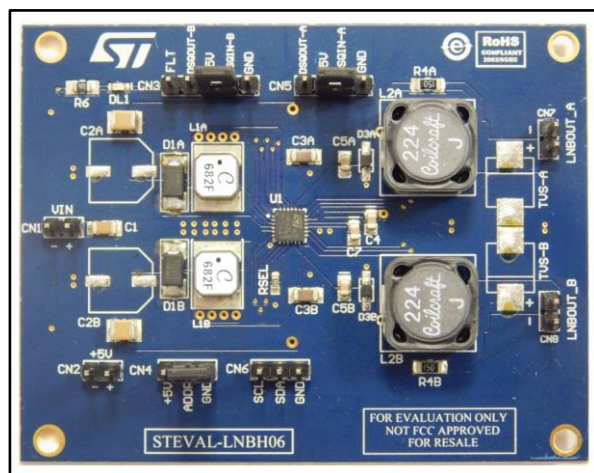

### Description

This evaluation board implements a DC-DC converter based on the LNBH26S device. It is used to power LNBs inside dish antennas to receive satellite TV signals.

The LNBH26S is an integrated solution for supplying / interfacing satellite LNB modules in accordance with international standards. This simple solution offers a complete solution for dual tuner satellite receivers and provides good performance at low cost using a low external component count.

The LNBH26S evaluation board includes an I<sup>2</sup>C bus interface and the internal 22 kHz tone generator which is factory trimmed and can be controlled by the DSQIN pin (TTL compatible), which allows immediate DiSEqC™ data encoding. Thanks to a fully integrated step-up DC-DC converter, it functions with a single input voltage supply source ranging from 8 V to 16 V.

### Features

- Complete interface between LNB and I<sup>2</sup>C bus
- Built-in DC-DC converter for single 12 V supply operation and high efficiency (typ. 93% @ 0.5 A)
- Selectable output current limit by external resistor
- Compliant with output voltage specifications for principal satellite receivers (15 programmable levels)
- Accurate built-in 22 kHz tone generator suits widely accepted standards
- 22 kHz tone waveform integrity guaranteed even at no load condition
- Low drop post regulator and high efficiency step-up PWM with integrated power N-MOS allowing low power losses
- LPM function (low power mode) to reduce dissipation
- Overload and overtemperature internal protection with I<sup>2</sup>C diagnostic bits
- LNB short-circuit dynamic protection
- ±4 kV ESD tolerant on output power pins
- RoHS compliant

# 1 Schematic diagram

Figure 1: STEVAL-LNBH06 circuit schematic

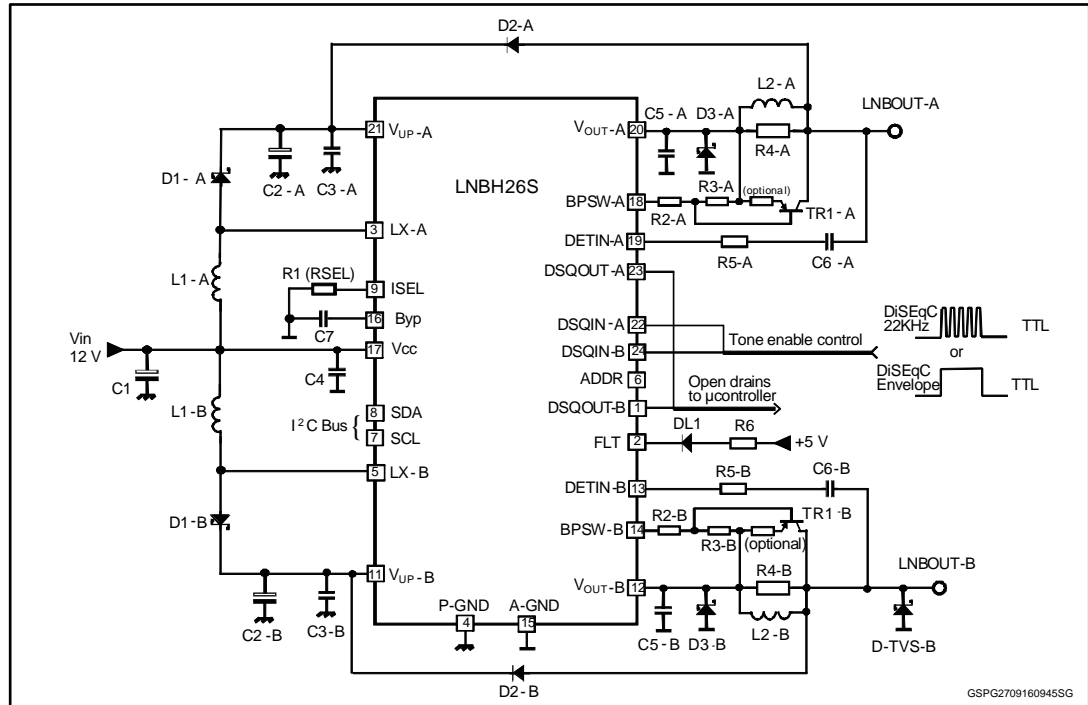

## 2 Revision history

Table 1: Document revision history

Date	Version	Changes
29-Sep-2016	1	Initial release.