

Professional MEMS tool: ST MEMS adapters motherboard based on the STM32F401VE and compatible with all ST MEMS adapters

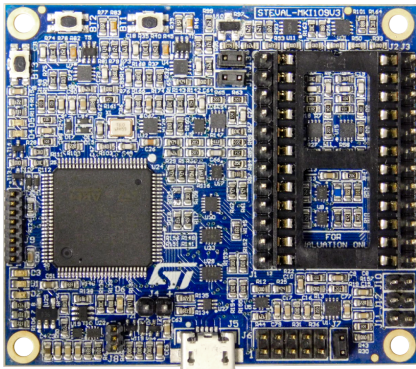

Features

- Compatible with all available ST MEMS adapter boards
- Controlled by the [STM32F401VE](#) high-performance ARM Cortex™ - M4 microcontroller
- Software-adjustable power circuitry to set sensor supply voltage from 0 to 3.6 V
- Includes a DIL24 socket for easy MEMS adapter connection
- Adjustable MEMS DIL24 power supply
- DFU-compatible for USB microprocessor firmware update
- USB 2.0 full-speed compliant
- Embedded power monitoring circuitry on sensor supply voltage and current
- Debugging connector for SWD/JTAG
- Can be used with PC software like Unico GUI to manage and analyze MEMS sensor data
- RoHS compliant

Description

ST's ready-to-use MEMS motherboard ([STEVAL-MKI109V3](#)) development platform lets engineers monitor the behavior of ST MEMS sensors, which can help accelerate time to market and maximize the performance of new product designs. This board is compatible with ST MEMS adapter boards and supports I2C and SPI data modes for very high output data rates.

This professional MEMS tool features a high-performance [STM32F401VE](#) microcontroller and flexible power management with software-adjustable power circuitry that allows you to set the sensor supply voltage from 0 to 3.6 V and replicate the operating conditions in the intended application. The board includes accurate power monitoring on sensor supply voltage and current, so external instruments are not required.

You can run a graphical user interface (GUI) like Unico GUI ([STSW-MKI109L](#) for Linux, [STSW-MKI109M](#) for Mac OSX and [STSW-MKI109W](#) for Windows), on a host PC to manage data flow from MEMS sensors and analyze MEMS sensor waveforms, which can help you explore the operating modes and power settings to optimize sensor performance and accuracy in your application.

The [STM32F401VE](#) ARM Cortex-M4 microcontroller with DSP and FPU can process much more than sensor readings such as barometric pressure and accelerometer or gyroscope data; it can handle complex datasets like optical or electronic image stabilization (OIS and EIS, respectively) from ST's advanced 6-axis inertial modules, and can be used to evaluate the latest generation of high-resolution MEMS sensors for industrial applications.

Product summary	
ST MEMS adapter motherboard based on STM32F401VE compatible ST MEMS adapters	STEVAL-MKI109V3
High-performance access line, ARM Cortex-M4 core with DSP and FPU, 512 Kbytes Flash, 84 MHz CPU, ART Accelerator	STM32F401VE
MEMS evaluation kit software package for Linux	STSW-MKI109L
MEMS evaluation kit software package for Mac OS X	STSW-MKI109M
MEMS evaluation kit software package for Windows	STSW-MKI109W

1 Schematic diagrams

Figure 1. STEVAL-MKI109V3 circuit schematic (1 of 8)

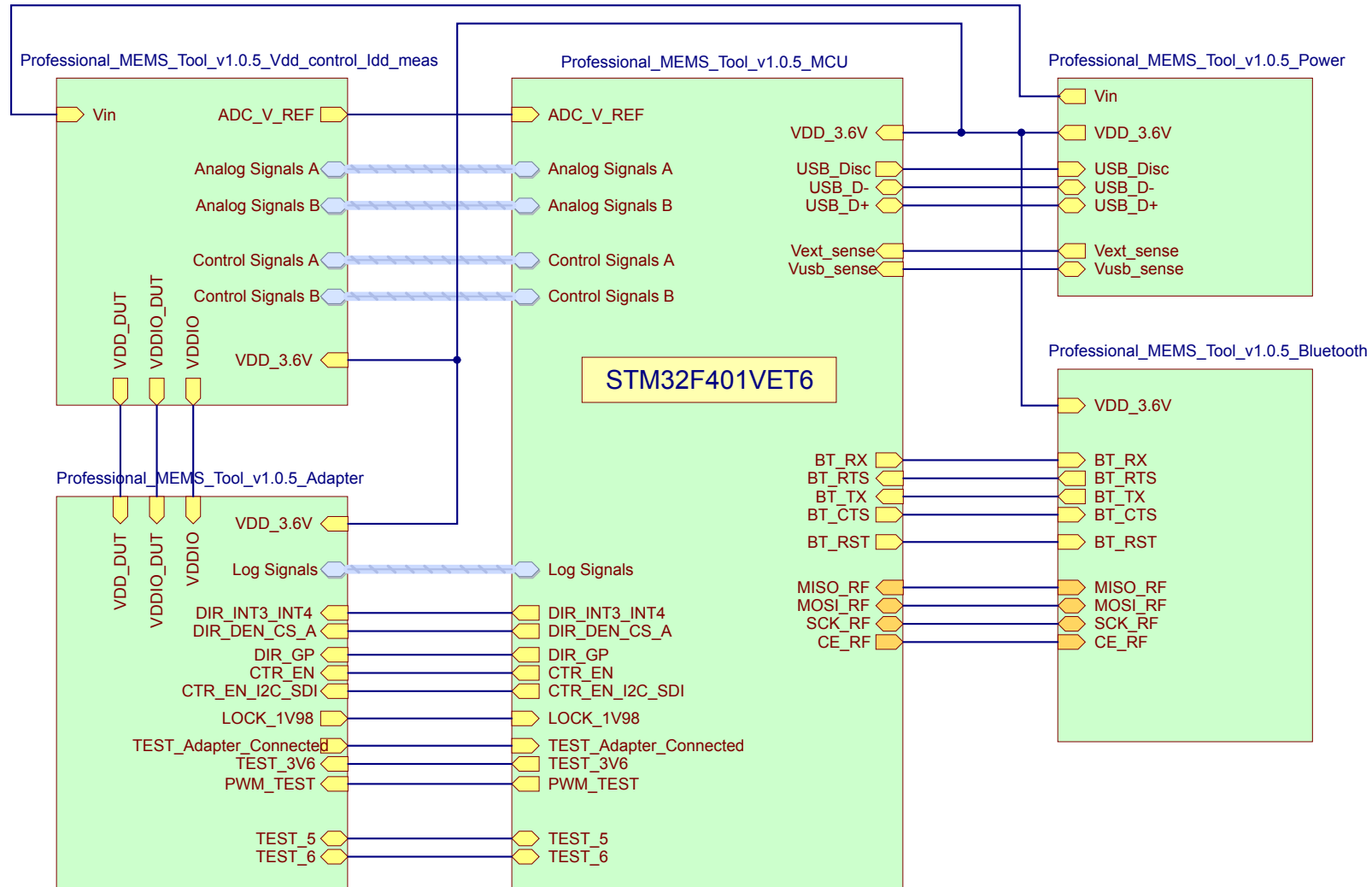

Figure 2. STEVAL-MK1109V3 circuit schematic (2 of 8)

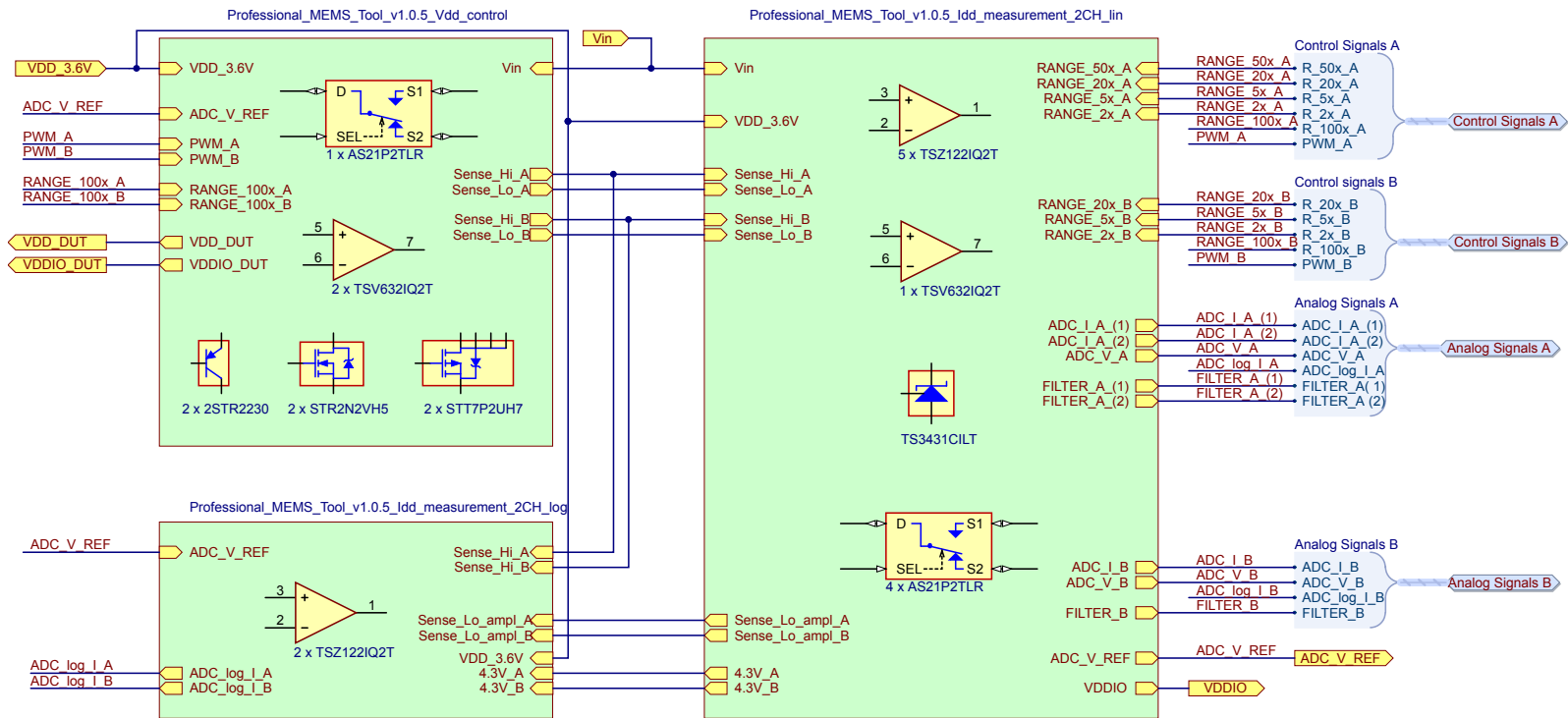
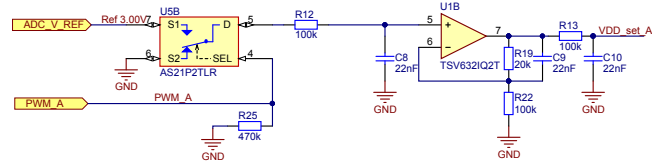

Figure 3. STEVAL-MK1109V3 circuit schematic (3 of 8)
Dual channel Vdd control



PWM + Filter

CH_A



CH_B

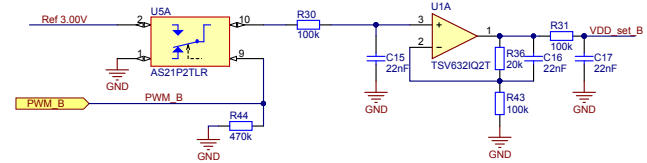

PWM controlled Power Supply

CH_A

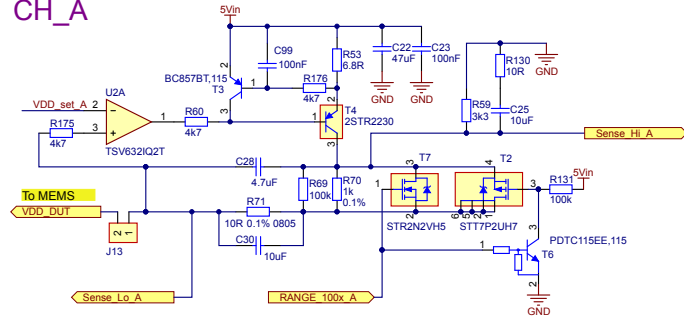

CH_B

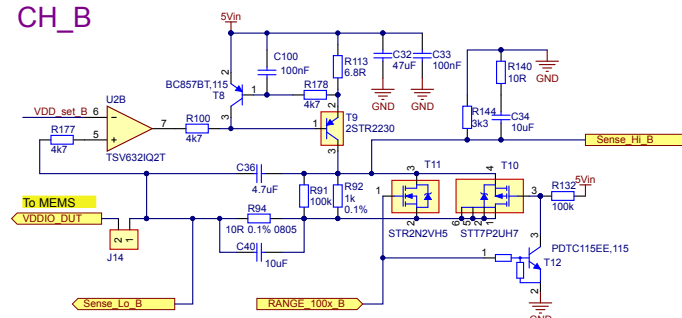

To MEMS

VDD_DUT

J13

Sense Lo_A

RANGE 100x A

VDD_3.6V -3.6V

Vin FB1 5Vin

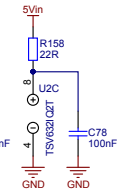
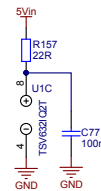
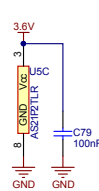

Figure 4. STEVAL-MK1109V3 circuit schematic (4 of 8)

V1 - Dual Channel Idd measurement - lin

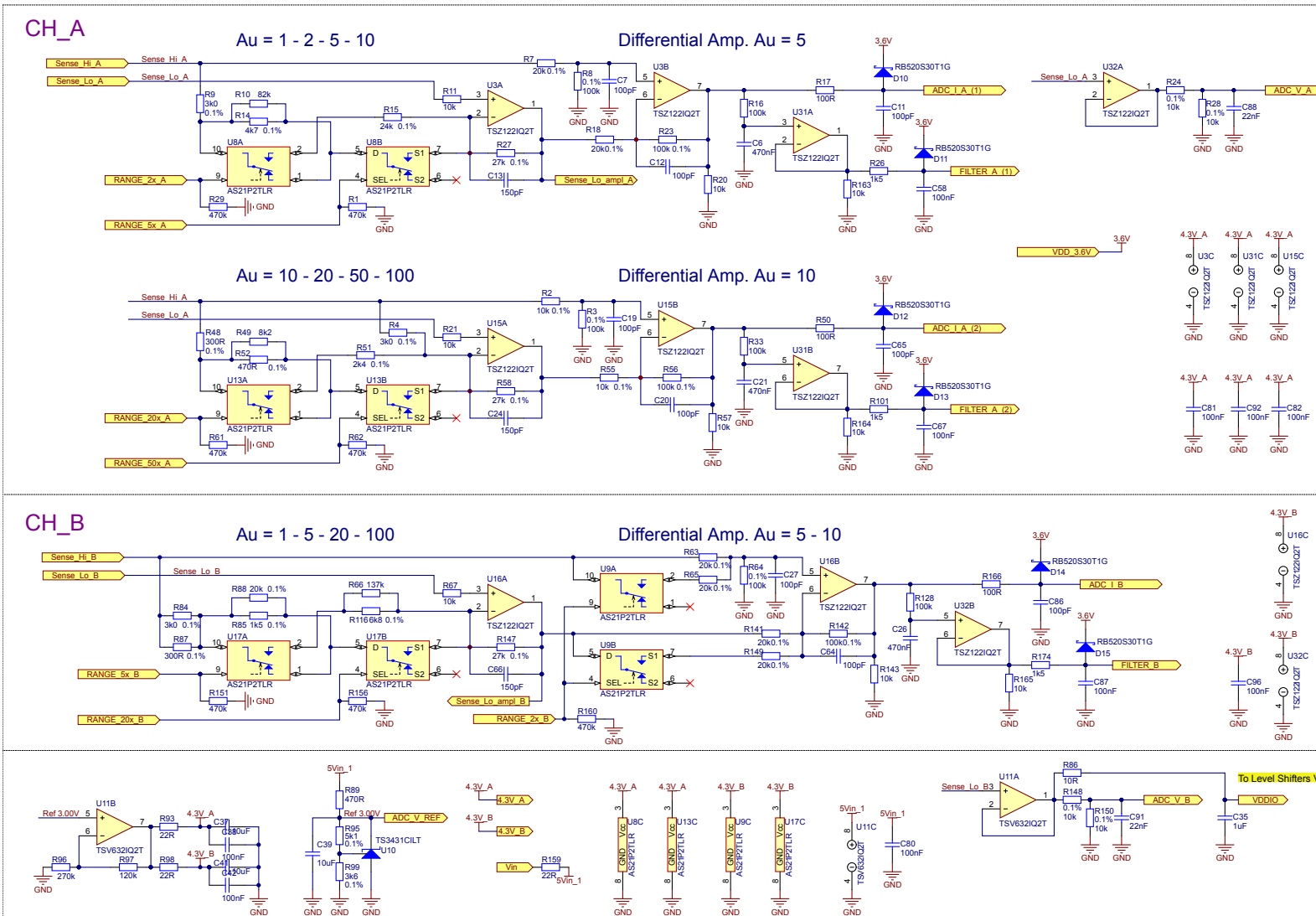
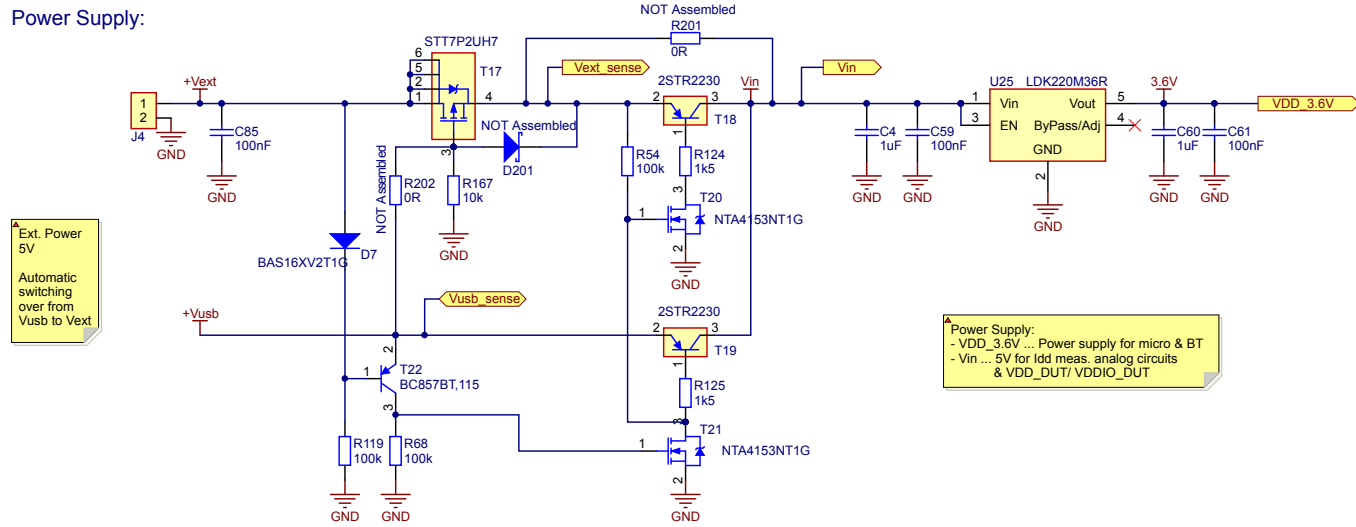

Figure 5. STEVAL-MK1109V3 circuit schematic (5 of 8)

Power Supply:



USB Connection:

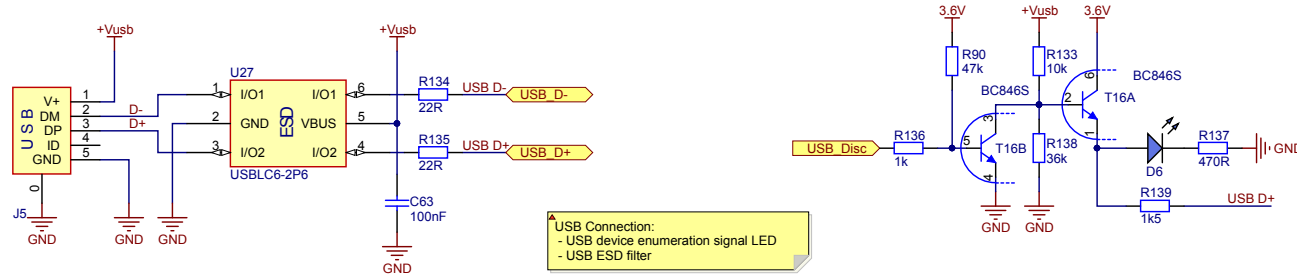
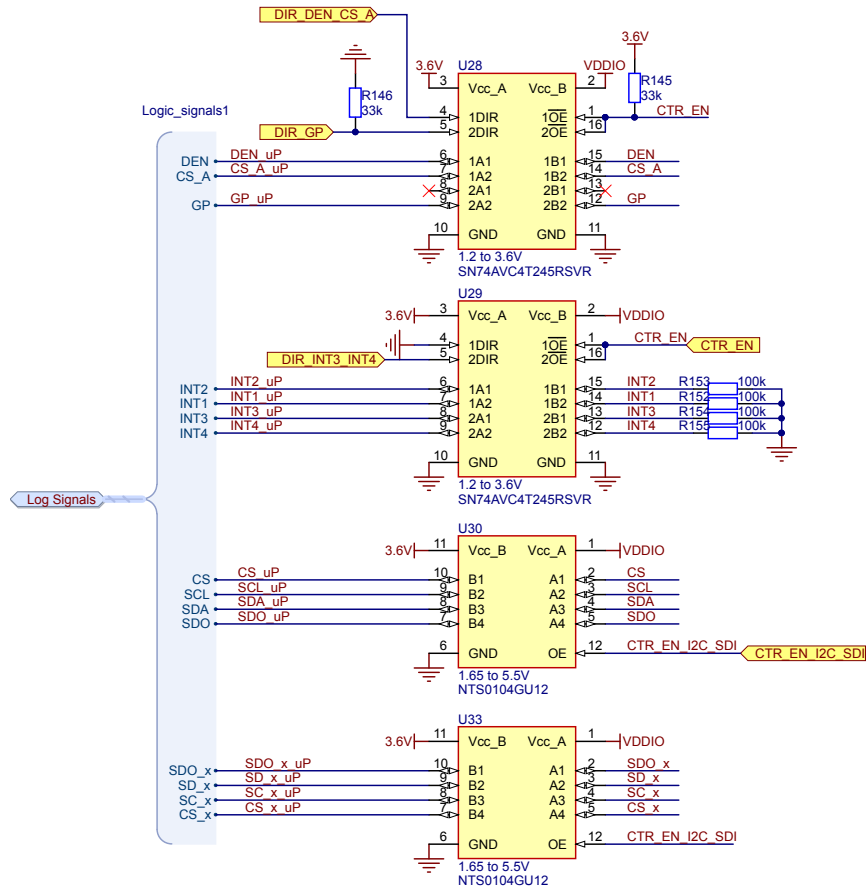

Figure 6. STEVAL-MK1109V3 circuit schematic (6 of 8)

Level Translation:



DIL24 Device Adapter:

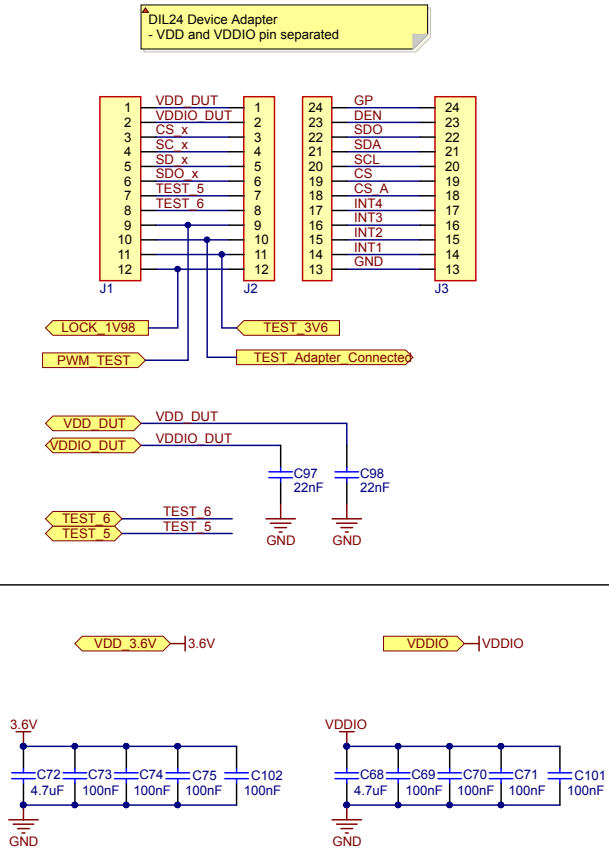
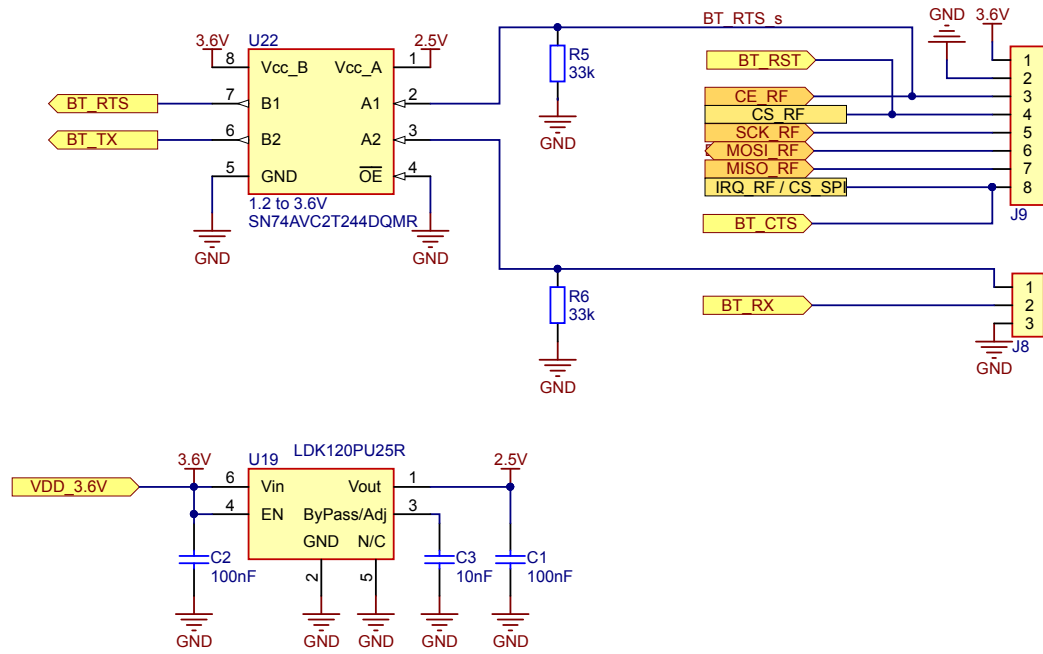

Figure 7. STEVAL-MK1109V3 circuit schematic (7 of 8)

Bluetooth Module Connection:



Revision history

Table 1. Document revision history

Date	Version	Changes
04-Jul-2016	1	Initial release.
12-Apr-2019	2	Updated cover page Section Features and Section Description Added Section Product summary table