

A3G4250D adapter board for a standard DIL24 socket

Data brief

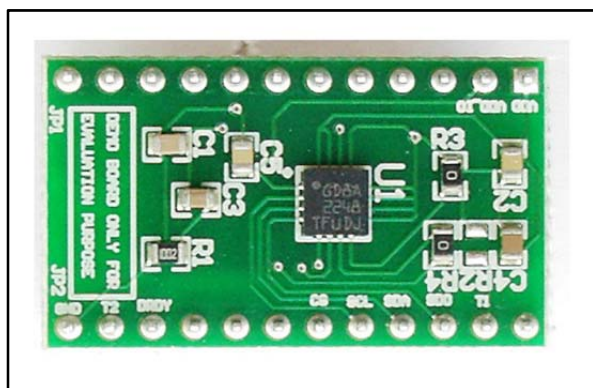

Features

- Complete A3G4250D pinout for a standard DIL 24 socket
- Fully compatible with the STEVAL-MKI109V2 motherboard
- RoHS compliant

Description

The STEVAL-MKI125V1 is an adapter board designed to facilitate the evaluation of MEMS devices in the A3G4250D product family. The board offers an effective solution for fast system prototyping and device evaluation directly within the user's own application.

The STEVAL-MKI125V1 can be plugged into a standard DIL 24 socket. The adapter provides the complete A3G4250D pinout and comes ready-to-use with the required decoupling capacitors on the V_{DD} power supply line.

This adapter is supported by the STEVAL-MKI109V2 motherboard which includes a high performance 32-bit microcontroller functioning as a bridge between the sensor and a PC, on which it is possible to use the downloadable graphical user interface (Unico GUI), or dedicated software routines for customized applications.

1 Schematic diagram

Figure 1: STEVAL-MKI125V1 circuit schematic

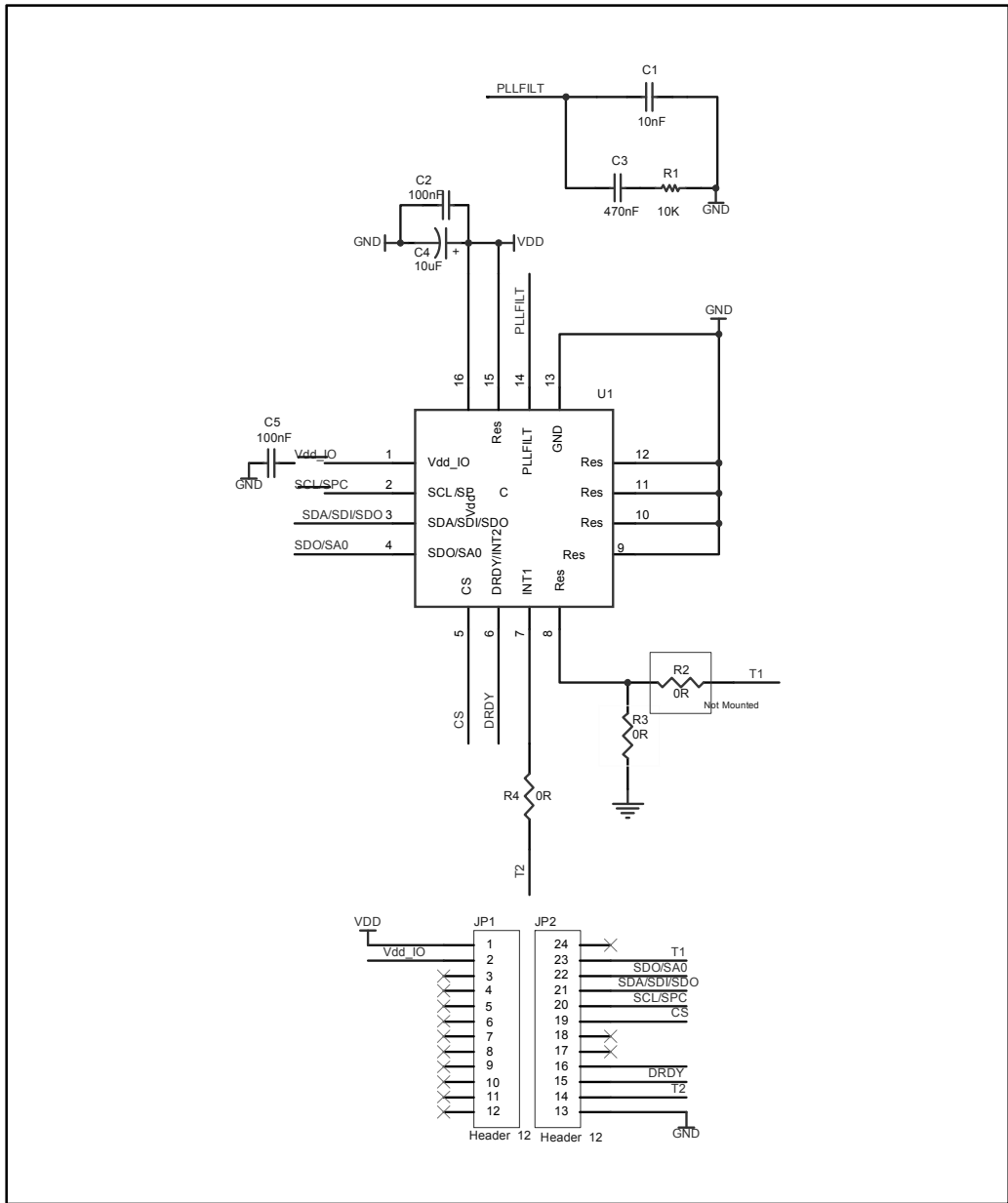

2 Revision history

Table 1: Document revision history

| Date | Revision | Changes |
|-------------|----------|--|
| 10-May-2013 | 1 | Initial release. |
| 15-Nov-2013 | 2 | Updated features and description to include information on the STEVAL-MKI109V2 motherboard and related software. |