

Microphone coupon board based on the MP23AB01DH fully differential analog MEMS microphone



Features

- 4 x MP23AB01DH bottom port analog MEMS microphones
- Vsupply from 2.3 to 3.6 V
- 135 dB SPL acoustic overload point
- Omnidirectional sensitivity
- Frequency range 100 Hz - 10 kHz
- 65 dB of SNR
- Sensitivity -38 dBV \pm 1 dBV
- THD < 0.2% @ 94 dB SPL, 1 kHz
- THD < 5% @ 130 dB SPL, 1 kHz
- RoHS compliant

Description

The STEVAL-MKI139V5 daughterboard contains four [MP23AB01DH](#) analog MEMS microphones.

The coupon concept facilitates performance testing of ST MEMS microphones. It is possible to detach the single PCBs hosting each microphone.

Product summary	
High-performance MEMS microphone, fully differential analog bottom-port, omnidirectional, high SNR, compact and low-power MEMS audio sensor	MP23AB01DH

1 Schematic diagrams

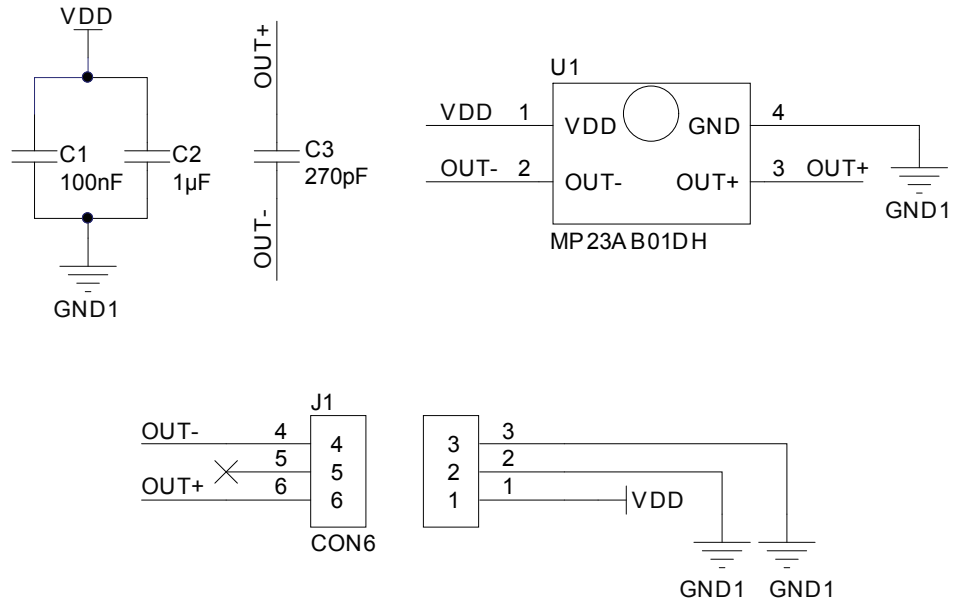
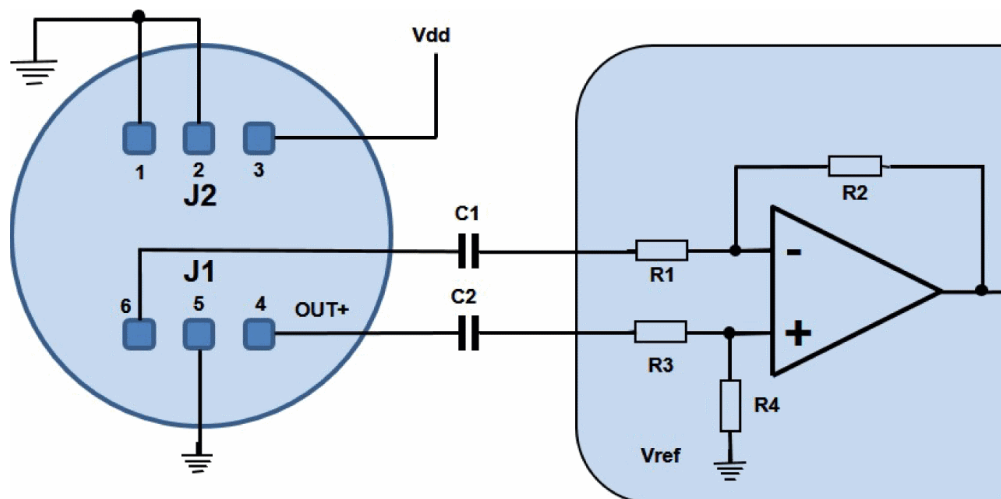
Figure 1. STEVAL-MKI139V5 coupon circuit schematic

Figure 2. STEVAL-MKI139V5 example of external electrical connections

$$V_{out} = \frac{R1+R2}{R3+R4} * \frac{R4 * (OUT+)}{R1} - \frac{R2 * (OUT-)}{R1}$$

In Case $R1=R3$ and $R2=R4$

$$V_{out} = \frac{R2}{R1} * ((OUT+) - (OUT-))$$

Revision history

Table 1. Document revision history

Date	Version	Changes
12-May-2017	1	Initial release.
07-May-2018	2	Added logo in cover page, updated Section • Features, added Section • Product summary table