

## LPS25HB adapter board for a standard DIL 24 socket

Data brief

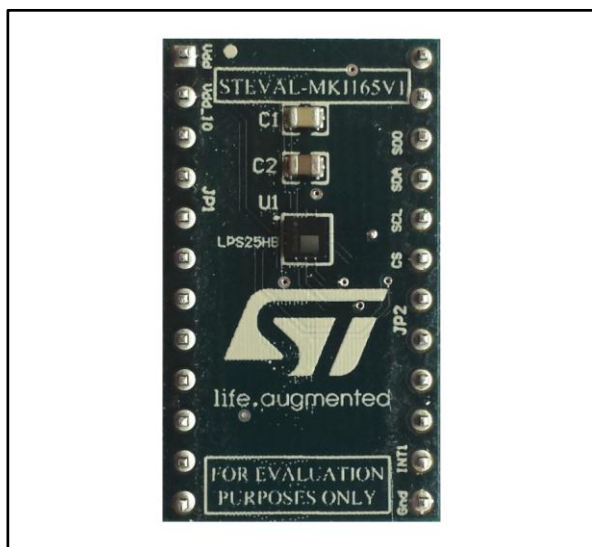

### Description

The STEVAL-MKI165V1 is an adapter board designed to facilitate the evaluation of MEMS devices in the LPS25HB product family. The board offers an effective solution for fast system prototyping and device evaluation directly within the user's own application.

The STEVAL-MKI165V1 can be plugged into a standard DIL 24 socket. The adapter provides the complete LPS25HB pinout and comes ready-to-use with the required decoupling capacitors on the  $V_{DD}$  power supply line. This adapter is supported by the STEVAL-MKI109V2 motherboard which includes a high performance 32-bit microcontroller functioning as a bridge between the sensor and a PC, on which it is possible to use the downloadable graphical user interface (Unico GUI), or dedicated software routines for customized applications.

### Features

- Complete LPS25HB pinout for a standard DIL 24 socket
- Fully compatible with the STEVAL-MKI109V2 motherboard
- RoHS compliant

# 1 Schematic diagram

Figure 1: STEVAL-MKI165V1 circuit schematic

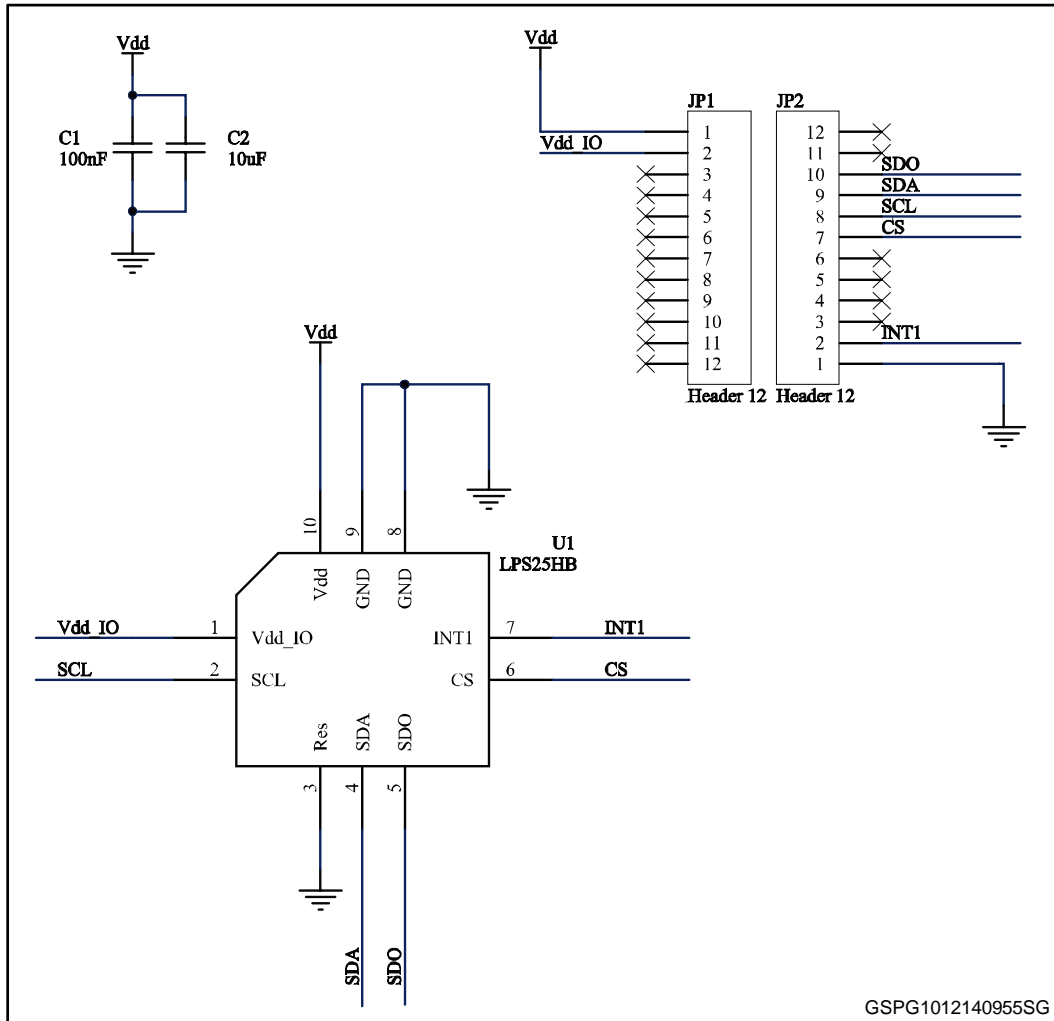

## 2 Revision history

Table 1: Document revision history

Date	Rev	Changes
12-Dec-2014	1	First release.