

H3LIS200DL adapter board for a standard DIL 24 socket

Data brief

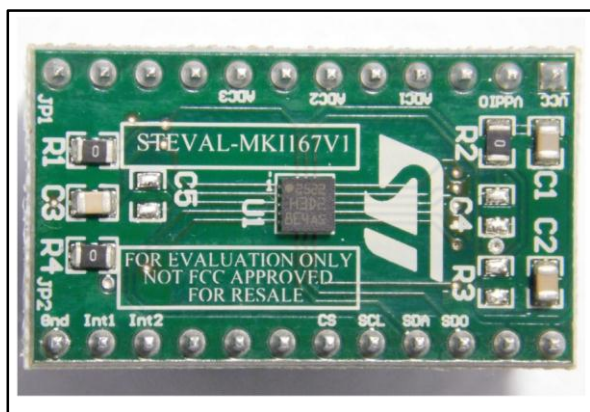

Features

- Complete H3LIS200DL pinout for a standard DIL 24 socket
- Fully compatible with the STEVAL-MKI109V2 motherboard
- RoHS compliant

Description

The STEVAL-MKI167V1 is an adapter board designed to facilitate the evaluation of MEMS devices in the H3LIS200DL product family. The board offers an effective solution for fast system prototyping and device evaluation directly within the user's own application.

The STEVAL-MKI167V1 can be plugged into a standard DIL 24 socket. The adapter provides the complete H3LIS200DL pinout and comes ready-to-use with the required decoupling capacitors on the V_{DD} power supply line.

This adapter is supported by the STEVAL-MKI109V2 motherboard which includes a high performance 32-bit microcontroller functioning as a bridge between the sensor and a PC, on which it is possible to use the downloadable graphical user interface (Unico GUI), or dedicated software routines for customized applications.

1 Schematic diagram

Figure 1: STEVAL-MKI167V1 circuit schematic

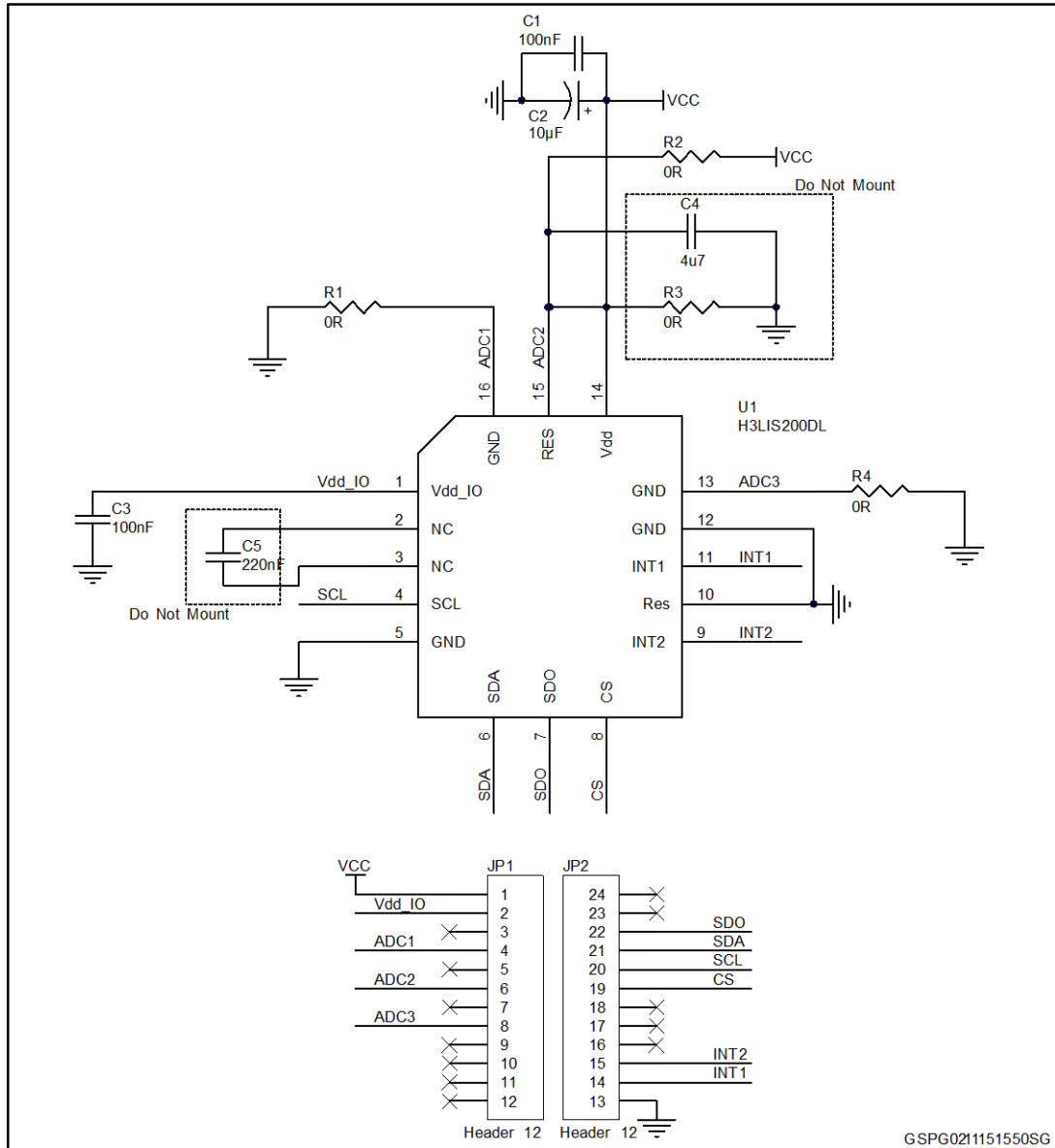

2 Revision history

Table 1: Document revision history

Date	Version	Changes
12-Nov-2015	1	Initial release.