

## LIS2DE12 adapter board for standard DIL24 socket

Data brief

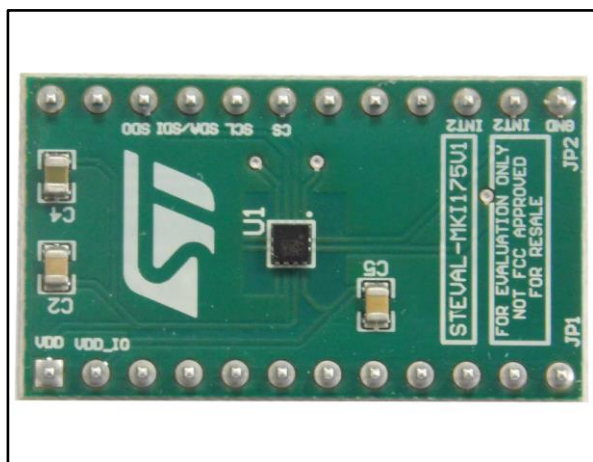

### Features

- Complete LIS2DE12 pinout for a standard DIL24 socket
- Fully compatible with the STEVAL-MKI109V2 and STEVAL-MKI109V3 motherboards
- RoHS compliant

### Description

The STEVAL-MKI175V1 is an adapter board designed to facilitate the evaluation of MEMS devices in the LIS2DE12 product family. The board offers an effective solution for fast system prototyping and device evaluation directly inside the user application.

The STEVAL-MKI175V1 can be plugged into a standard DIL24 socket. The adapter provides the complete LIS2DE12 pin-out and comes ready-to-use with the required decoupling capacitors on the  $V_{DD}$  power supply line.

This adapter is supported by the STEVAL-MKI109V2 and STEVAL-MKI109V3 motherboards, which include a high performance 32-bit microcontroller functioning as a bridge between the sensor and a PC, on which it is possible to use the downloadable graphical user interface (Unico GUI) or dedicated software routines for customized applications.

# 1 Schematic diagram

Figure 1: STEVAL-MKI175V1 circuit schematic

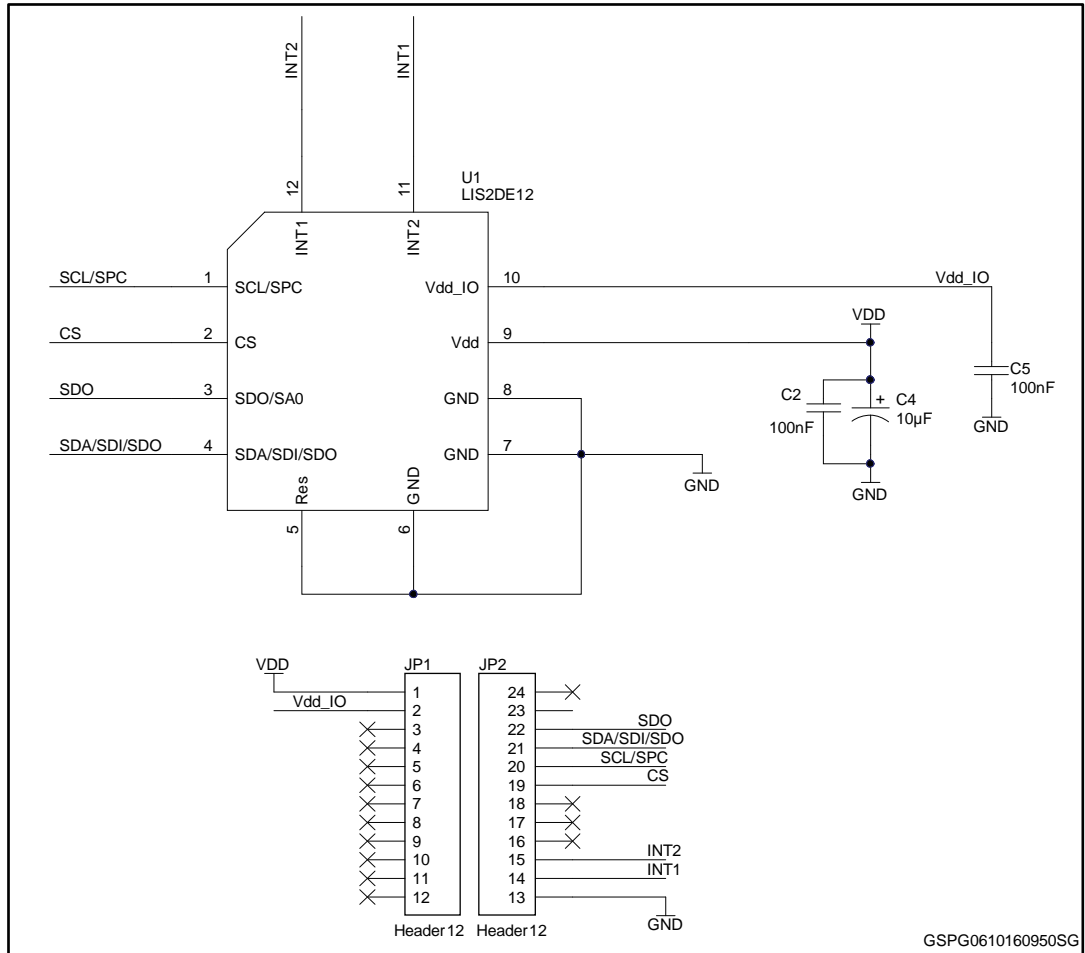

## 2 Revision history

Table 1: Document revision history

Date	Version	Changes
10-Oct-2016	1	Initial release.