

3-axis digital accelerometer sensor kit based on IIS3DWB

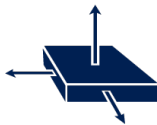

Features

- User friendly IIS3DWB board
- Complete IIS3DWB pinout for a standard DIL 24 socket
- Fully compatible with STEVAL-MKI109V3 motherboard
- Double-sided adhesives included for easy mounting on equipment to be measured
- RoHS and WEEE compliant

Description

The STEVAL-MKI208V1K evaluation board has an embedded IIS3DWB 3D accelerometer sensor, which is connected via cable to a simple adapter board (STEVAL-MKIGIBV2) to render it compatible with STEVAL-MKI109V3 motherboards.

The sensor is soldered precisely in the center of the board and double-sided adhesives are provided to allow users to conveniently mount the board on equipment destined for vibration analysis. Alternatively, you can mount the board using the holes located in each corner of the PCB.

The STEVAL-MKIGIBV2 can be plugged into a standard DIL 24 socket. The kit provides the complete IIS3DWB pin-out and comes ready-to-use with the required decoupling capacitors on the VDD power supply line.

The STEVAL-MKI109V3 motherboards feature a high performance 32-bit microcontroller functioning as a bridge between the sensor and a PC running the free Unico GUI graphical user interface or dedicated software routines for customized applications.

Product summary	
iNemo inertial module kit based on IIS3DWB	STEVAL-MKI208V1K
Ultra-wide bandwidth (up to 6 kHz), low-noise, 3-axis digital vibration sensor	IIS3DWB
ST MEMS adapter motherboard based on STM32F401VE compatible ST MEMS adapters	STEVAL-MKI109V3
Application	IoT for Smart Things

1 Schematics

Figure 1. STEVAL-MKI208V1 board schematic

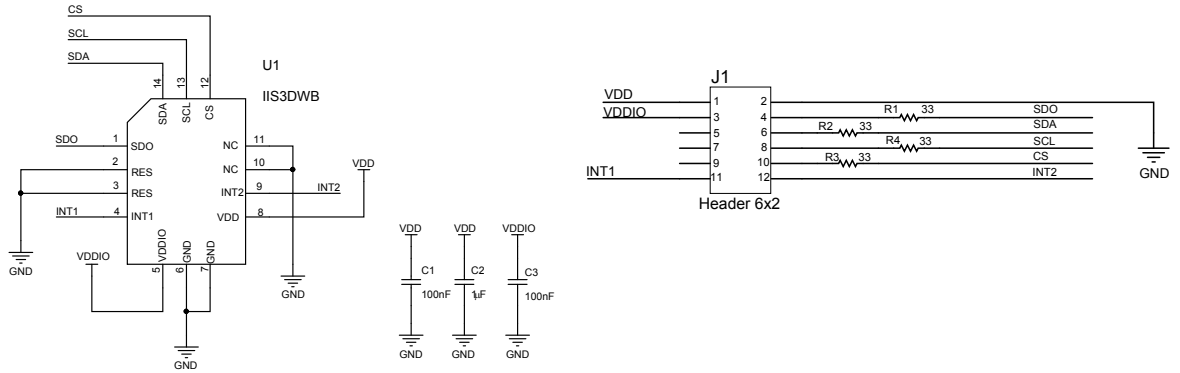
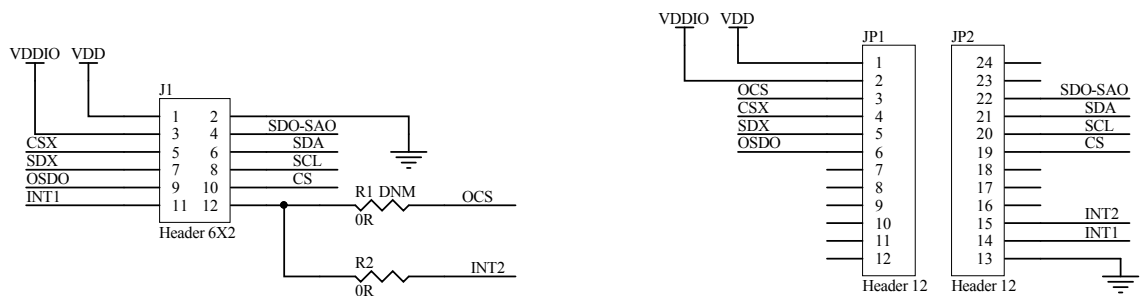

Figure 2. STEVAL-MKIGIBV2 board schematic



Revision history

Table 1. Document revision history

Date	Version	Changes
10-Dec-2019	1	Initial release.
11-Mar-2020	2	Updated description.
05-Nov-2020	3	Updated title.