

IS330IS evaluation kit with embedded ISPU for usage with NanoEdge.AI Studio

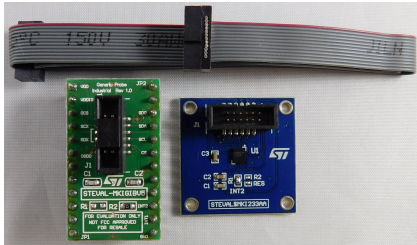

Features

- Complete ISM330IS pinout for a standard DIL 24 socket
- Fully compatible with the STEVAL-MKI109V3 motherboard
- RoHS compliant

Description

The STEVAL-MKI233KA evaluation kit consists of the STEVAL-MKI233A main sensing board, with a square PCB, which mounts the ISM330IS 3-axis accelerometer and 3-axis gyroscope with embedded ISPU, the STEVAL-MKIGIBV5 adapter board, and a flat cable. The main board is connected to the adapter board through the flat cable to make it compatible with the STEVAL-MKI109V3.

The sensing board can be directly attached to the system to be measured through the provided adhesive.

The ISM330IS is soldered exactly in the center of the board.

The STEVAL-MKIGIBV5 can be plugged into a standard DIL 24 socket. The kit provides the complete ISM330IS pinout and comes ready-to-use with the required decoupling capacitors on the VDD power supply line.

This adapter is supported by the STEVAL-MKI109V3 motherboard, which includes a high-performance 32-bit microcontroller functioning as a bridge between the sensor and a PC, on which it is possible to use the downloadable graphical user interface (Unico-GUI), or dedicated software routines for customized applications.

Product summary	
IS330IS evaluation kit with embedded ISPU for usage with NanoEdge.AI Studio	STEVAL-MKI233KA
iNEMO inertial module: always-on 3D accelerometer and 3D gyroscope with embedded ISPU	ISM330ISNTR
MEMS adapter motherboard based on the STM32F401VE	STEVAL-MKI109V3
Motion MEMS and microphone MEMS expansion board for STM32 Nucleo	X-NUCLEO-IKS02A1
Applications	Industrial Robots

1 Schematic diagrams

Figure 1. STEVAL-MKIGIBV5 circuit schematic

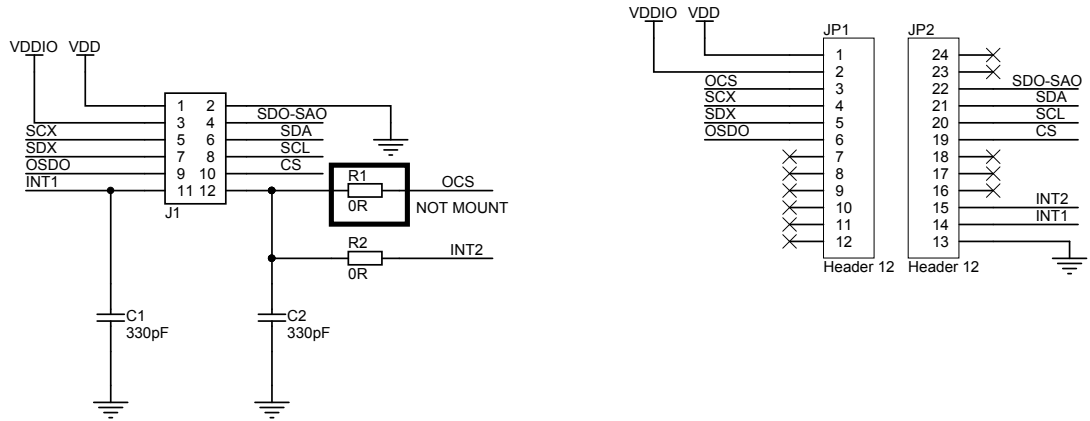
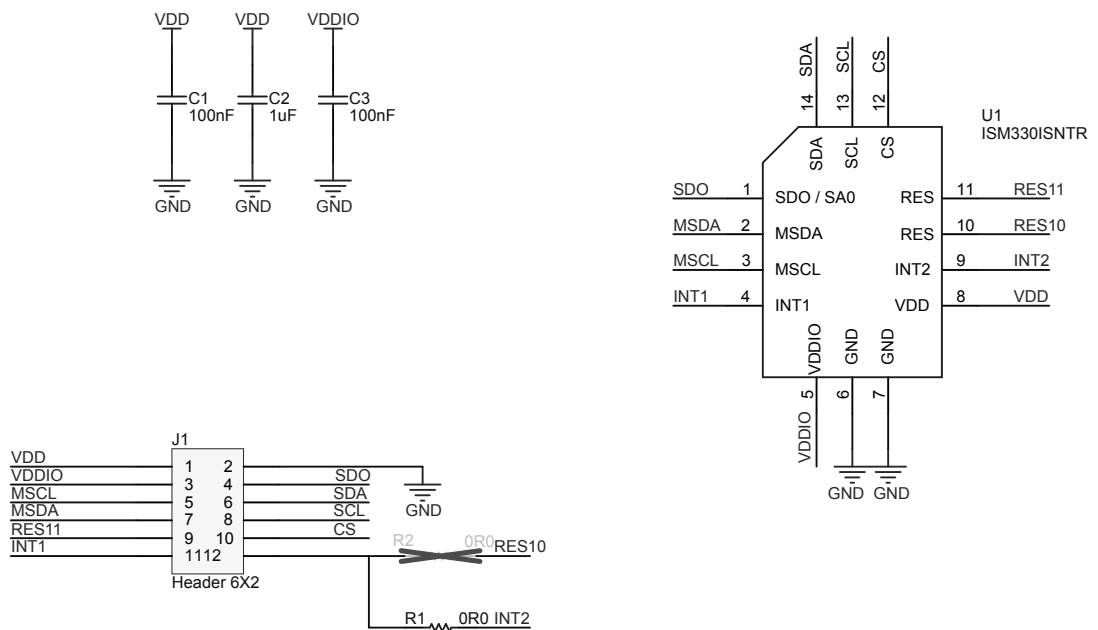

Figure 2. STEVAL-MKI233A circuit schematic



2 Kit versions

Table 1. STEVAL-MKI233KA versions

PCB version	Schematic diagrams	Bill of materials
STEVAL\$MKI233KAA ⁽¹⁾	STEVAL\$MKI233KAA schematic diagrams	STEVAL\$MKI233KAA bill of materials

1. This code identifies the STEVAL-MKI233KA evaluation kit first version. The kit consists of a STEVAL-MKI233AA whose version is identified by the code STEVAL\$MKI233AAA and a STEVAL-MKIGIBV5 whose version is identified by the code STEVAL\$MKIGIBV5A.

Revision history

Table 2. Document revision history

Date	Revision	Changes
29-Aug-2022	1	Initial release.