

MDI BRR board for EMIF02-01OABRY or EMIF02-02OABRY

Data brief

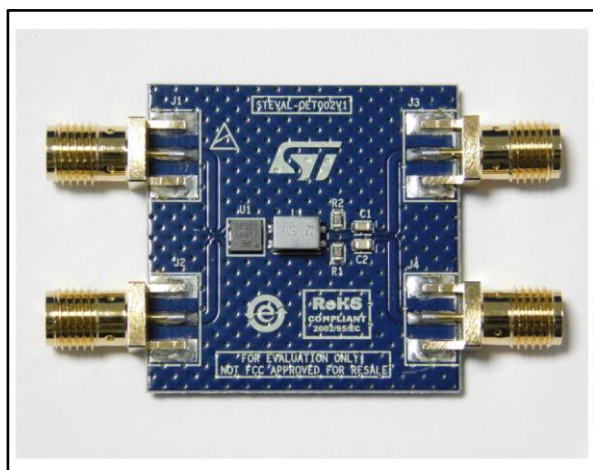

Description

The STEVAL-OET002V1 is a medium-dependent interface (MDI) board which includes the EMIF02-01OABRY filter, in compliance with BroadR-Reach™ specifications for EMI, ESD and differential impedance. BroadR-Reach™ (BRR) is an Ethernet, two unshielded twisted pair (UTP) wire protocol for data communication.

The STEVAL-OET002V1 board is able to filter parasitic and undesirable common and differential signals.

Features

- Includes the EMIF02-01OABRY highly integrated solution designed to suppress EMI noise and protect against ESD
- Attenuation profile compliant with BroadR-Reach™ requirements, from -40 °C to 125 °C
- Compliant with ISO10605, ISO7637-3 standards
- RoHS compliant

1 Schematic diagram

Figure 1: STEVAL-OET002V1 circuit schematic

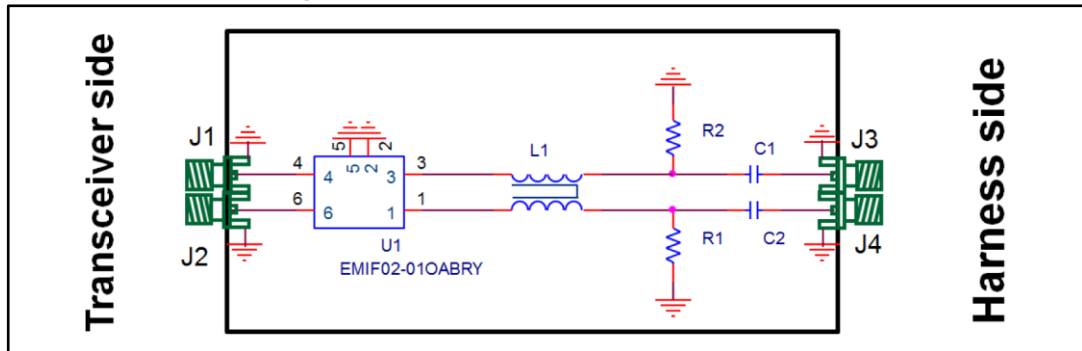

The board schematic shows four RF SMA connectors (J1, J2, J3 and J4) for the following connections:

- the board to VNA to check Sddxx curves
- for BRR communication (e.g., from camera to display):
 - the BroadR-Reach transceiver wires (TRD_N and TRD_P pins) and GND on transceiver side (J1, J2)
 - UTP on harness side (no GND needed) (J3, J4).

Thanks to EMIF02-01OABR, ESD and transient voltages can be applied on MDI without transceiver failure.

For more information, refer to the *BroadR-Reach Transceiver EMC Test Specification*.

2 Revision history

Table 1: Document revision history

Date	Version	Changes
22-Jun-2016	1	Initial release.
03-Oct-2016	2	Updated title on the cover page.