

## Industrial PLC evaluation board with HMI interface



### Features

- **STM32F746ZGT7** high-performance MCU embedding ARM® 32-bit Cortex®-M7 CPU with FPU, Chrom-ART accelerator, and DSP instructions
- **CLT01-38SQ7** octal high-speed digital input current limiter with SPI interface
- **CLT03-2Q3** dual-channel self-powered digital input current limiter
- **ISO8200AQ** galvanic isolated octal high-side smart power solid-state relay with SPI interface
- **IPSA4260L** quad low-side intelligent power switch
- Main supply voltage: 18 - 32 V (24 V nominal)
- **STSW-PLC001** firmware package
- 3.5" TFT display with multitouch capability interfaced through dedicated parallel, digital RGB ports and I<sup>2</sup>C lines
- **STLD40DPUR**-based display back-light LED driver with controllable intensity
- Morpho connectors for expansion connectivity options
- Screw connectors for safer power supply and industrial IO connections
- USB connector for alternate 5 V source power supply (only for display powering and MCU programming/debug)
- Isolated USART port connector
- SWD connector for debugging and programming
- Status LEDs for inputs, outputs, and various fault conditions
- Debug LEDs
- Reset button
- Protections against surge, EMI, and input reverse voltage connection
- EMC pad and four-layer routing
- On-board RAM and serial Flash (ROM)
- Provision for RTC, USB (with one or more additional components to be mounted)
- Designed to meet IEC industrial standard requirements
- RoHS

Product summary	
Industrial PLC evaluation board with HMI interface	STEVAL-PLC001V1
Evaluation firmware for STEVAL-PLC001V1	STSW-PLC001
Self-powered digital input current limiter	CLT03-2Q3
High speed digital input current limiter	CLT01-38SQ7
Galvanic isolated octal high side smart power solid state relay	ISO8200AQ
Quad low-side intelligent power switch	IPSA4260L
High-performance and DSP with FPU ARM Cortex-M7 MCU	STM32F746ZGT7
Applications	Programmable Logic Controllers (PLC)

### Description

The **STEVAL-PLC001V1** evaluation board targets compact programmable logic controller (PLC) applications in the factory automation domain. It features a powerful human machine interface (HMI) thanks to the 3.5" TFT touchscreen mounted on the PCB, which eases interaction with the tool.

The board implements a galvanically isolated PLC control unit with robust digital input, digital output modules, expansion connectivity options, and interfaces.

The control unit consists of a powerful 144-pin **STM32F746ZGT7** MCU, which handles the industrial IOs on one side and the TouchGFX display technology on the other side, implementing the ladder logic programming code and several additional options.

Highly robust and reliable industrial digital input and output modules are placed symmetrically on the PCB, making the system a 12+12 PLC, that is, a PLC GUI optimized for STM32 microcontrollers, which manages 12 industrial inputs and 12 industrial outputs.

The 12 industrial inputs have been implemented through the combination of an eight-channel [CLT01-38SQ7](#) and two dual channel [CLT03-2Q3](#) ICs.

The [CLT01-38SQ7](#) features 6.25 MHz SPI with daisy chain capability to connect, in this case, the eight-channel output [ISO8200AQ](#) and reverse polarity, whereas the [CLT03-2Q3](#) features two high- and low-side compatible independent channels, which can be powered from the external sensors they interface with, and the capability of running in the 60 V range for fail-safe applications.

The 12 industrial output array consists of an eight-channel [ISO8200AQ](#) IC and a four-channel [IPS4260L](#) low-side intelligent power switch.

The [ISO8200AQ](#) offers a daisy-chain SPI interface and embedded galvanic insulation, separating logic and power side of 4 kV and making the solution cost-effective (no opto-coupler is needed).

The [STEVAL-PLC001V1](#) also features connectivity options typical of commercial PLCs through the morpho connectors mounted on the PCB bottom, ensuring compatibility with [STM32 Nucleo expansion boards](#).

The embedded ICs for industrial IO management allow great flexibility in terms of technical features, protections and embedded diagnostics, when interfacing industrial range inputs (that is, sensors and valves) and outputs (that is, lamps, alarms, and actuators) with the logic side.

The [STSW-PLC001](#) companion software package, freely available on [www.st.com](http://www.st.com), allows experimenting with these advanced features and their combination.

Thanks to this software and the smart user interface offered by the TouchGFX, you can learn how the ICs work and exploit ready-to-use examples as well as ladder logic demonstrations and projects.

# 1 Solution overview

The following block diagram shows the STEVAL-PLC001V1 architecture.

Figure 1. STEVAL-PLC001V1 functional block diagram

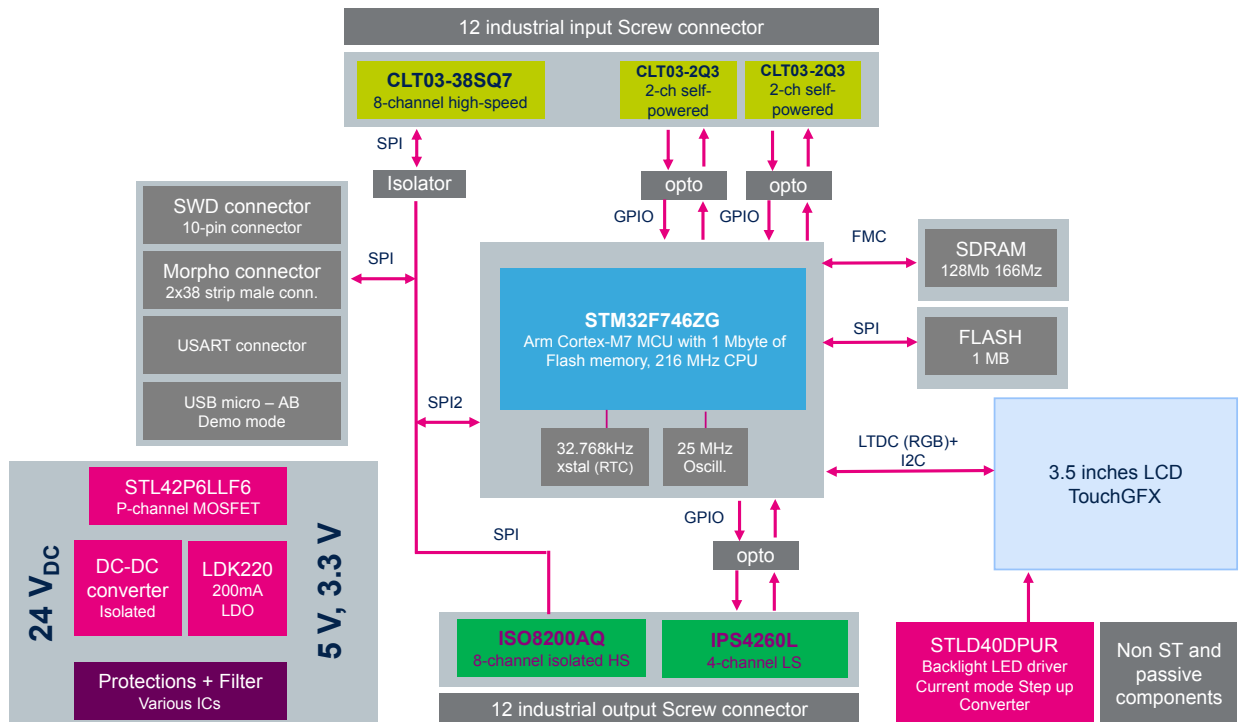

The main blocks are:

- the [STM32F746ZGT7](#) microcontroller;
- twelve industrial inputs managed through the eight-channel [CLT01-38SQ7](#) and the dual channel [CLT03-2Q3](#) mounted twice;
- twelve industrial outputs on the bottom handled by other two dedicated ICs: the eight-channel [ISO8200AQ](#) and the four-channel [IPS4260L](#).

The architecture also includes a 3.5" TFT display powered by the TouchGFX graphics engine for great flexibility in industrial IO management, giving abstraction from the hardware on one side, and full featured use of the ICs on the other side.

The morpho connectors allow connecting expansion boards and the USB connector allows supplying the board in case a 24 V power supply is not available.

Note:

When powered through the USB port, the [STEVAL-PLC001V1](#) has limited functionalities, as it works in demo mode, allowing display management and programming features but not high current rates on the industrial IOs.

A screw connector in the bottom-left corner is provided to power the board. All other isolated and logic supply voltages derive from this 24 V input after appropriate conditioning.

A P-channel MOSFET ensures reverse polarity protection, while other ICs are for EMI and surge protections.

A screw connector in the bottom-right corner powers field side devices.

## 2 Schematic diagrams

Figure 2. STEVAL-PLC001V1 circuit schematic (1 of 9)

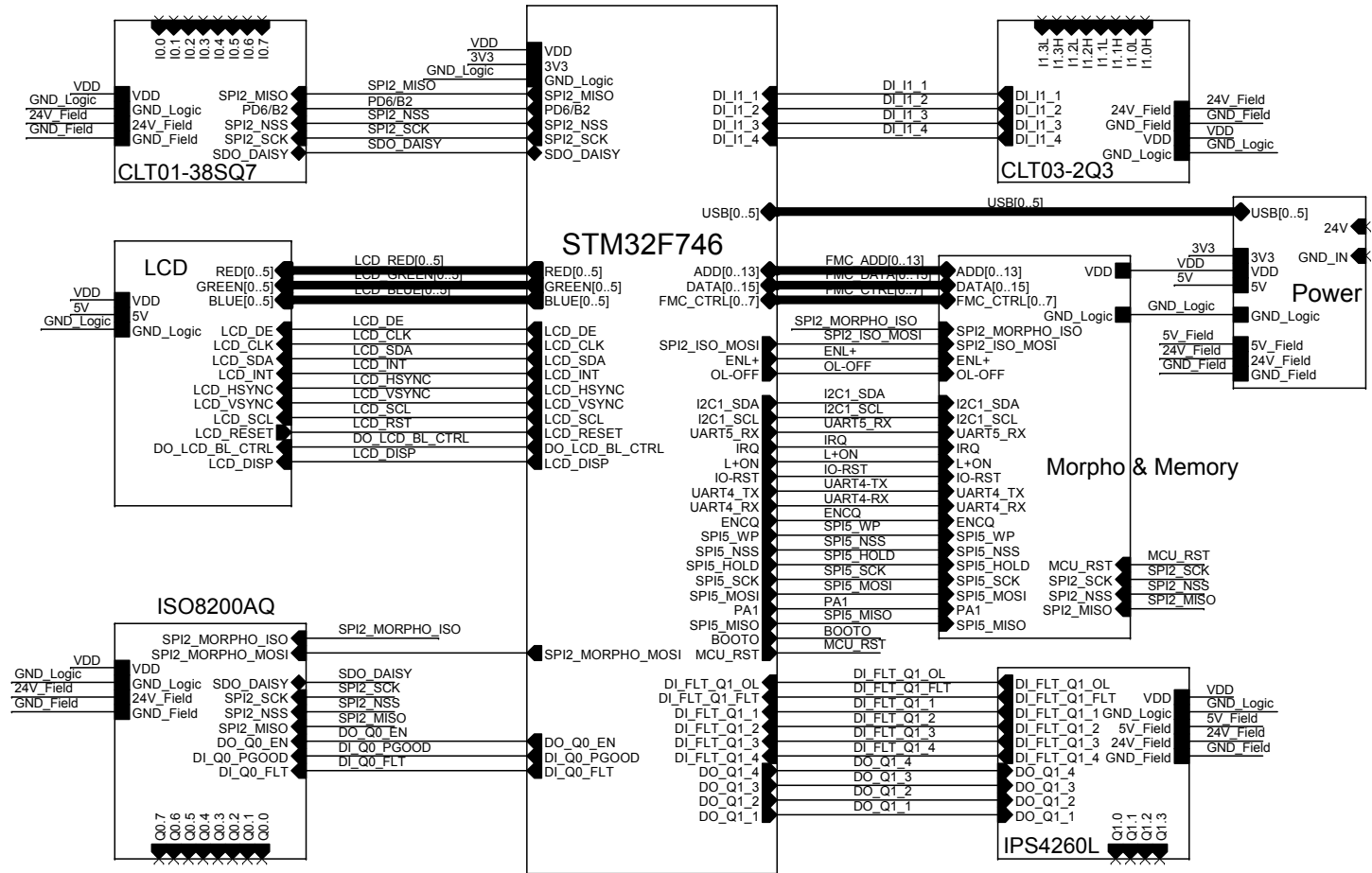

Figure 3. STEVAL-PLC001V1 circuit schematic (2 of 9)

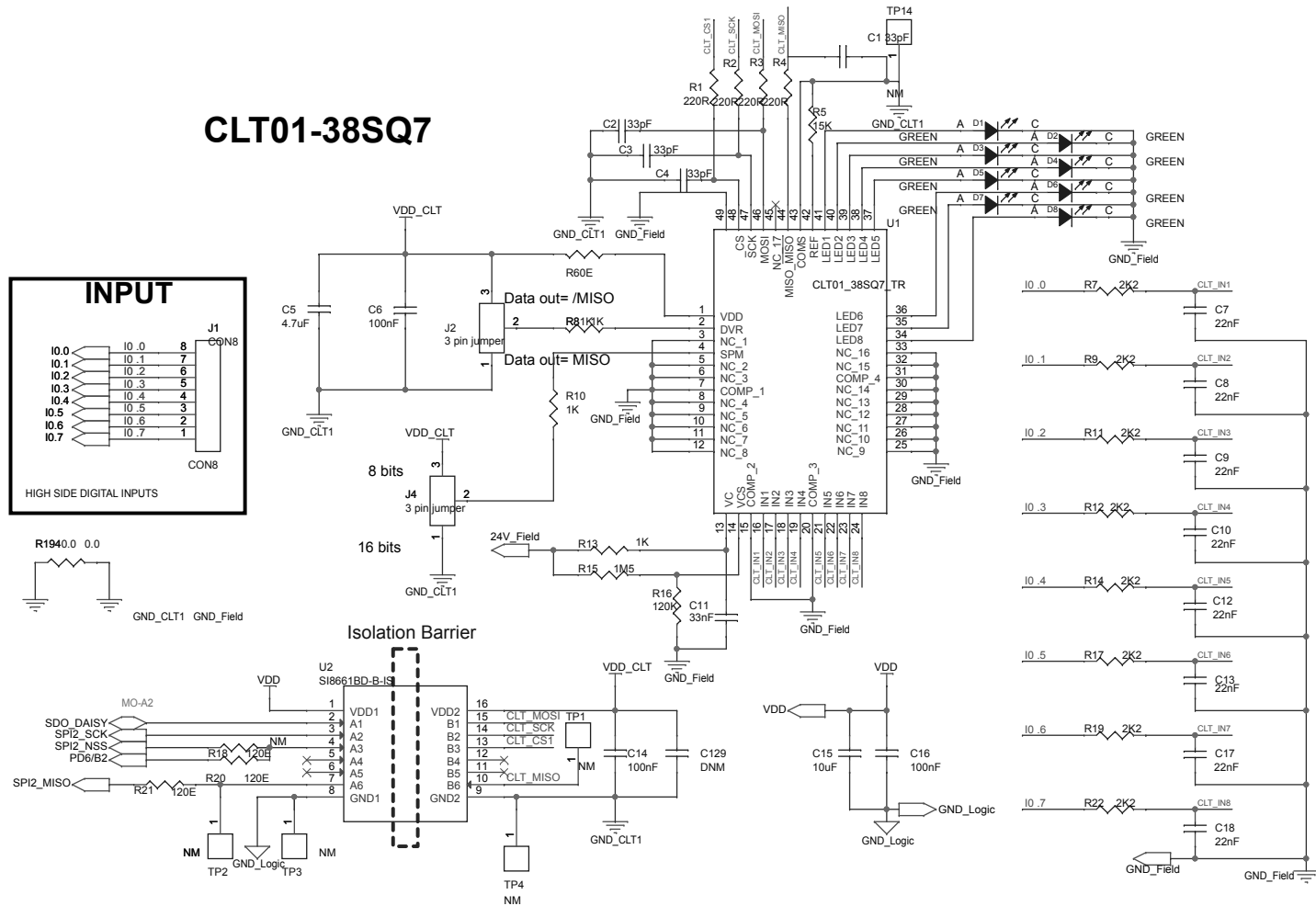

Figure 4. STEVAL-PLC001V1 circuit schematic (3 of 9)

### CLT03-2Q3

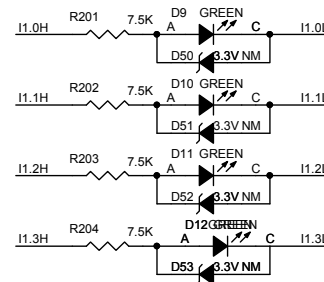
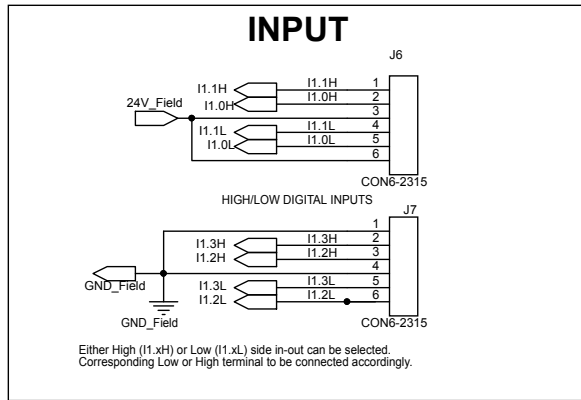
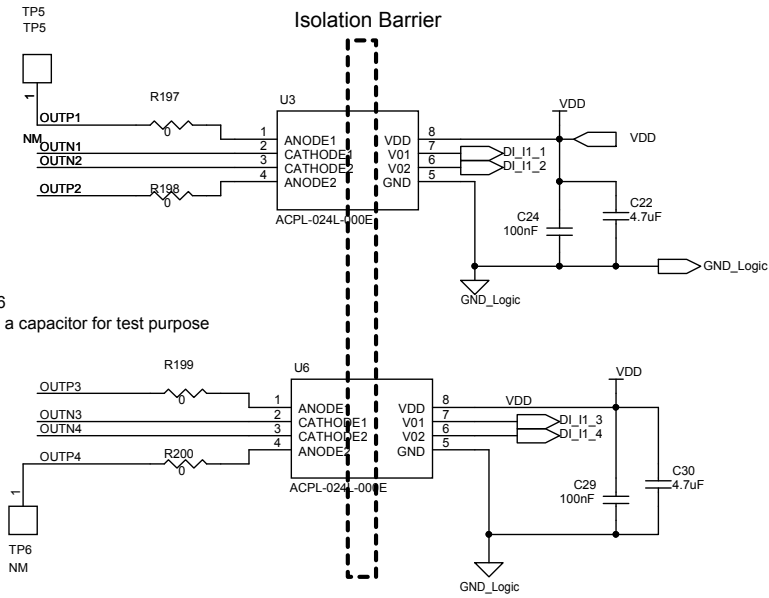
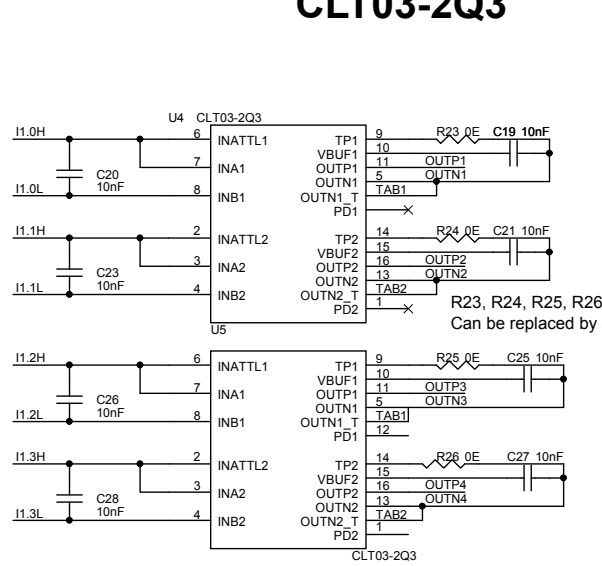
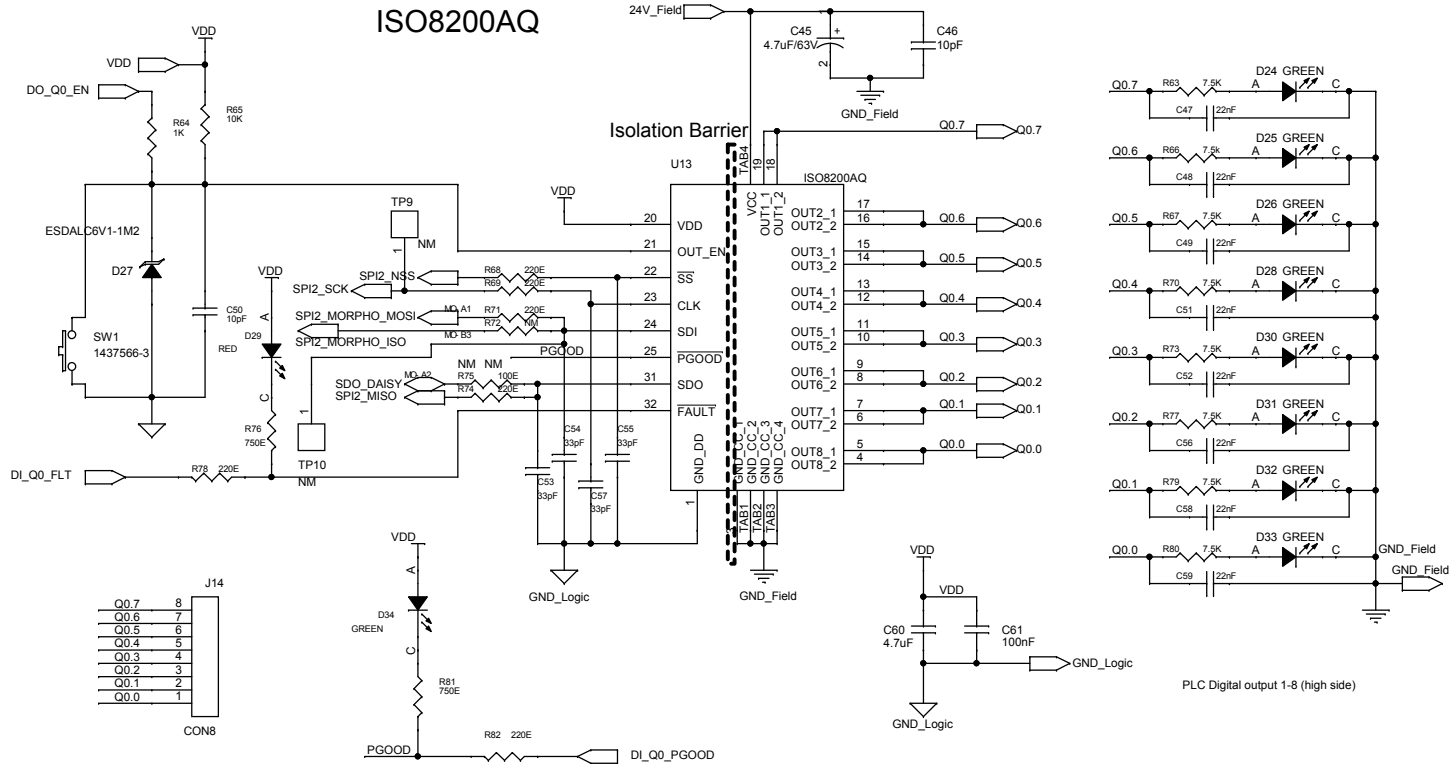

Figure 5. STEVAL-PLC001V1 circuit schematic (4 of 9)



PLC Digital output 1-8 (high side)



Figure 6. STEVAL-PLC001V1 circuit schematic (5 of 9)

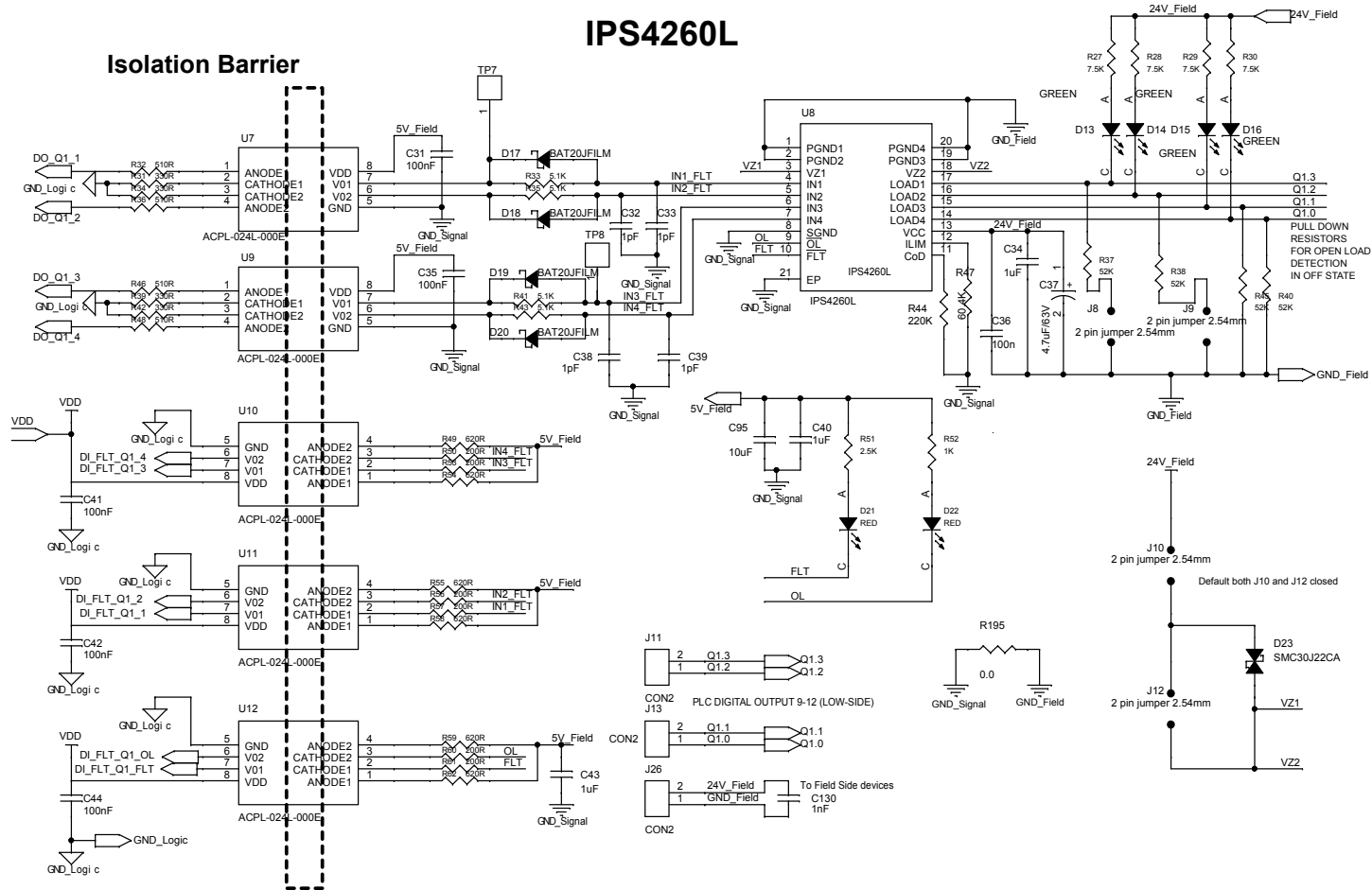





Figure 8. STEVAL-PLC001V1 circuit schematic (7 of 9)

Morpho & Memory

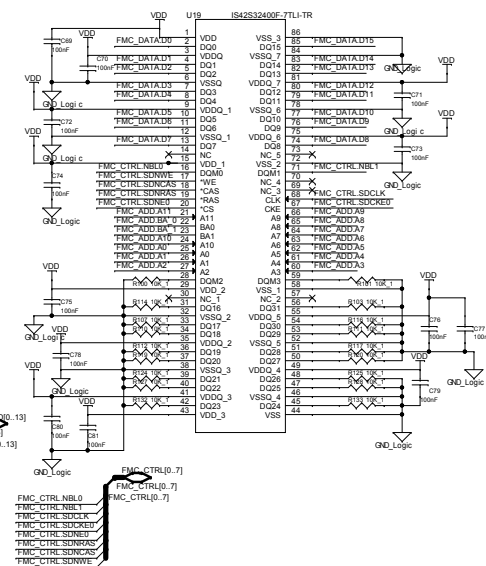
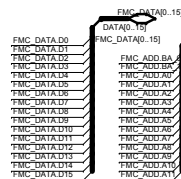
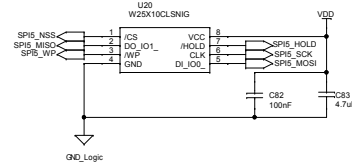
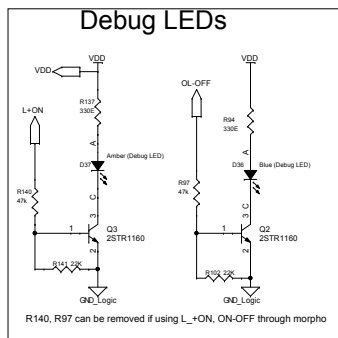
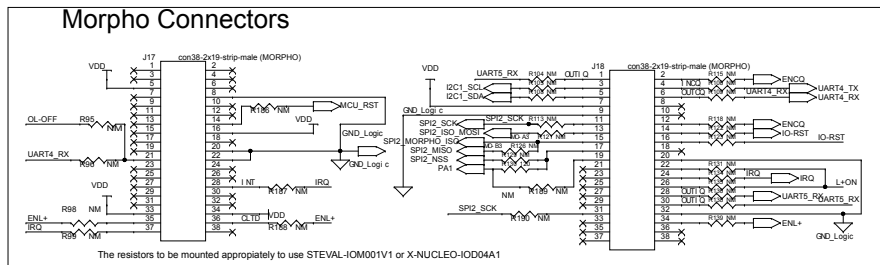

Figure 9. STEVAL-PLC001V1 circuit schematic (8 of 9)

### LCD

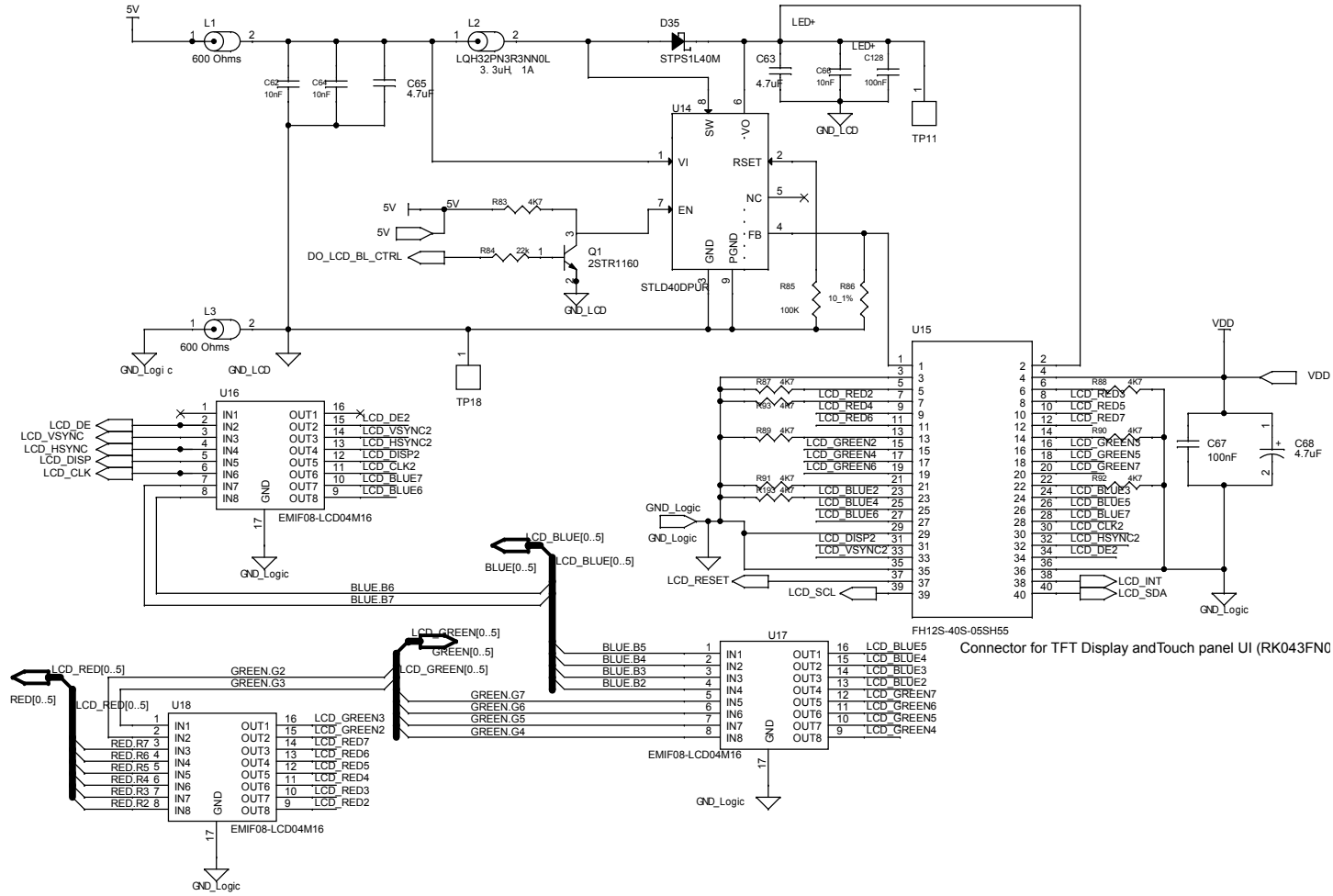
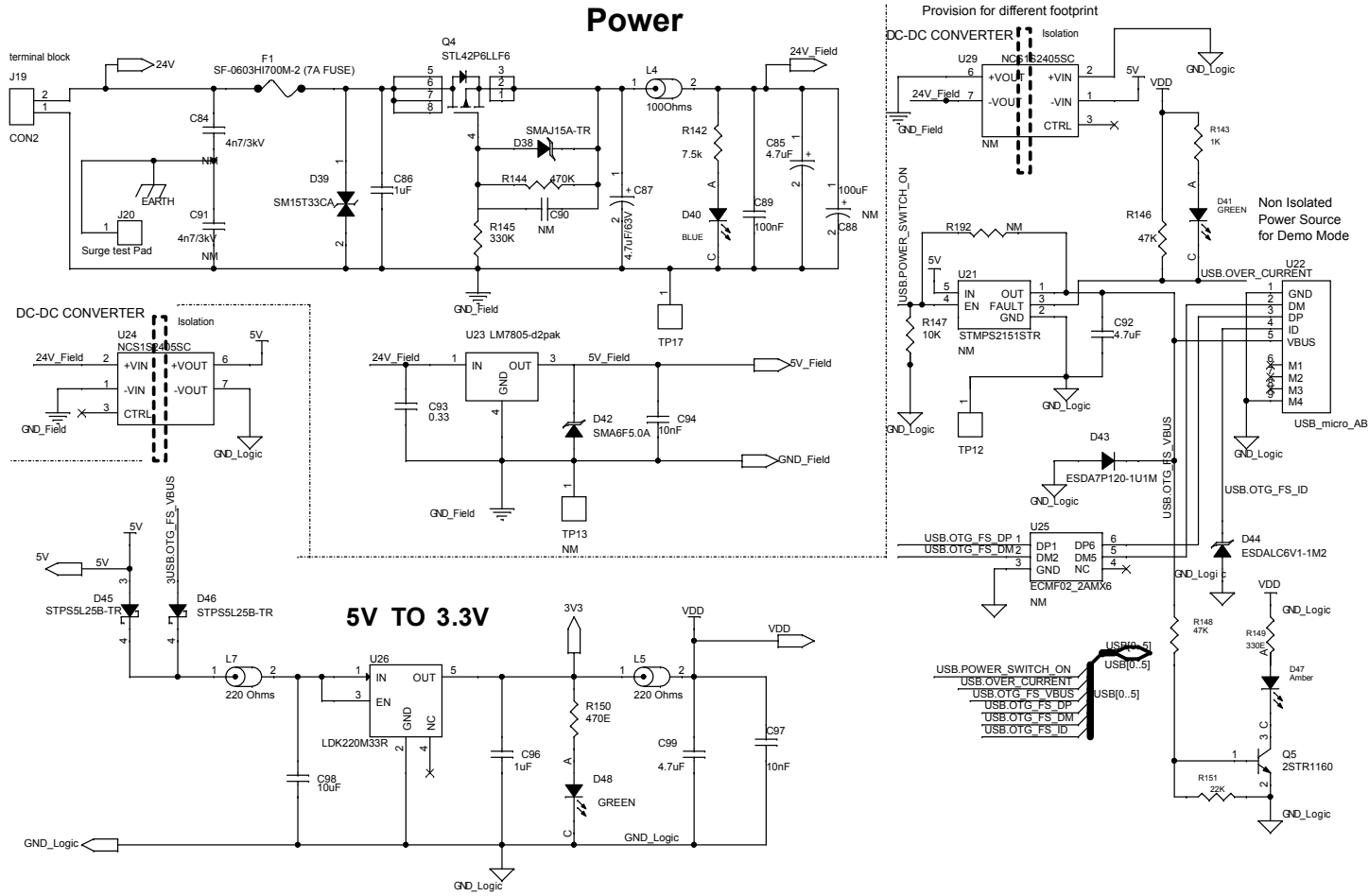

Figure 10. STEVAL-PLC001V1 circuit schematic (9 of 9)



### 3 Board versions

Table 1. STEVAL-PLC001V1 versions

Finished good	Schematic diagrams	Bill of materials
STEVAL\$PLC001V1A <sup>(1)</sup>	STEVAL\$PLC001V1A schematic diagrams	STEVAL\$PLC001V1A bill of materials

1. This code identifies the STEVAL-PLC001V1 evaluation board first version.

## Revision history

**Table 2. Document revision history**

Date	Revision	Changes
25-Oct-2021	1	Initial release.