

## NFC dynamic tag sensor and processing node evaluation board

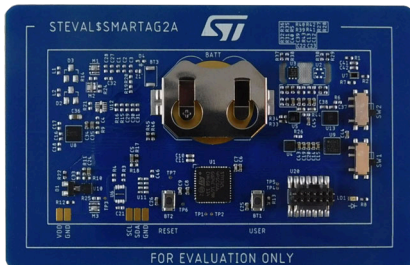

### Features

- **NFCSENSORTAG.BOX**: optimized form factor and encapsulated in a plastic case for testing
- **ST25DV64KC-JF6D3** dynamic NFC/RFID tag IC with 64-Kbit EEPROM and fast transfer mode capability
- **STM32L4P5-CGU6** ultra-low-power Arm® Cortex®-M4 32-bit MCU+FPU, 150 DMIPS, up to 1-MB flash memory, 320-KB SRAM, LCD-TFT, external SMPS
- **LSM6DSO32X** iNEMO 6 DoF inertial module with 32 g accelerometer and embedded machine learning core
- **LIS2DUXS12** ultra-low-power 3-axis smart accelerometer with machine learning core and Qvar
- **H3LIS331DL** MEMS motion sensor: low-power high-g 3-axis digital accelerometer
- **LPS22DF** low-power and high-precision MEMS nano pressure sensor: 260-1260 hPa absolute digital output barometer
- **STTS22H** low-voltage, ultra-low-power, 0.5 °C accuracy I<sup>2</sup>C/SMBus 3.0 temperature sensor
- **VD6283TX** Ambient Light Sensor with Hybrid filter multispectral and with embedded light flicker engine
- **STLQ020** 200 mA ultra-low quiescent current LDO
- **STBC15** ultra-low current consumption linear battery charger (optional component, not populated)
- **STSAFE-A110** authentication, state-of-the-art security for peripherals and IoT devices (optional component, not populated)
- **M41T62LC** low-power serial real-time clocks (RTCs) with alarm (optional component, not populated)
- CR2032 or LIR2032 battery powered (not included)
- STM32Cube function pack (**FP-SNS-SMARTAG2**)
- End-to-end proof of concept ecosystem mobile app and cloud dashboard:
  - **DSH-ASSETTRACKING** web cloud dashboard
  - **STAssetTracking** mobile app available on Google Play and App store
- Suitable for the following applications:
  - Internet of things
  - Supply chain and cold-chain management
  - Smart building, home, and city
  - Retail and apparel
  - Smart packaging
  - Medical and pharmaceutical
  - Batteryless sensing
  - Smart agriculture (soil control, animal tracking)
  - Asset tracking
  - Impact detection

### Product summary

| Product summary  |                                  |
|--|----------------------------------|
| NFC dynamic tag sensor and processing node evaluation board  | <a href="#">STEVAL-SMARTAG2</a>  |
| Dynamic NFC/RFID tag IC with 64-Kbit EEPROM, and fast transfer mode capability   | <a href="#">ST25DV64KC-JF6D3</a> |
| Ultra-low-power 3-axis smart accelerometer with machine learning core and Qvar   | <a href="#">LIS2DUXS12TR</a>     |
| Low-power and high-precision MEMS nano pressure sensor: 260-1260 hPa absolute digital output barometer                             | <a href="#">LPS22DFTR</a>        |
| Ambient Light Sensor with Hybrid filter multispectral and with embedded light flicker engine                                       | <a href="#">VD6283TX45/1</a>     |
| Low power High-g 3-axis accelerometer, SPI/I2C digital output MEMS motion sensor, user-selectable full scales of ±100g/±200g/±400g | <a href="#">H3LIS331DLTR</a>     |
| iNEMO inertial module: always-on 3D accelerometer and 3D gyroscope   | <a href="#">LSM6DSO32XTR</a>     |

| Product summary                                       |                                   |
|---|-----------------------------------|
| Cloud Amazon-based web application for asset tracking | <a href="#">DSH-ASSETTRACKING</a> |
| ST Asset Tracking application for Android and iOS     | <a href="#">STassetTracking</a>   |
| Applications  | <a href="#">IoT Applications</a>  |

## Description

The **STEVAL-SMARTAG2** is an NFC-enabled sensor node with inertial MEMS sensors and environmental sensors, an STM32 microcontroller, and a dynamic NFC tag for communication with NFC readers, such as tablets and smartphones.

Optionally, the **STEVAL-SMARTAG2** can be equipped with: a battery charger fed by a full-wave rectifier for NFC energy harvesting (on top of the energy harvester already embedded in the dynamic NFC tag), a secure element to support authentication and state-of-the-art crypto security, and a real-time clock (RTC) with an embedded crystal oscillator to enable an accurate timekeeping and time stamping.

The board has a small and thin form factor, comparable to the size of a credit card, which makes it particularly fit for deployment in the field and data collection.

# 1 Schematic diagrams

Figure 1. STEVAL-SMARTAG2 circuit schematic (1 of 6)

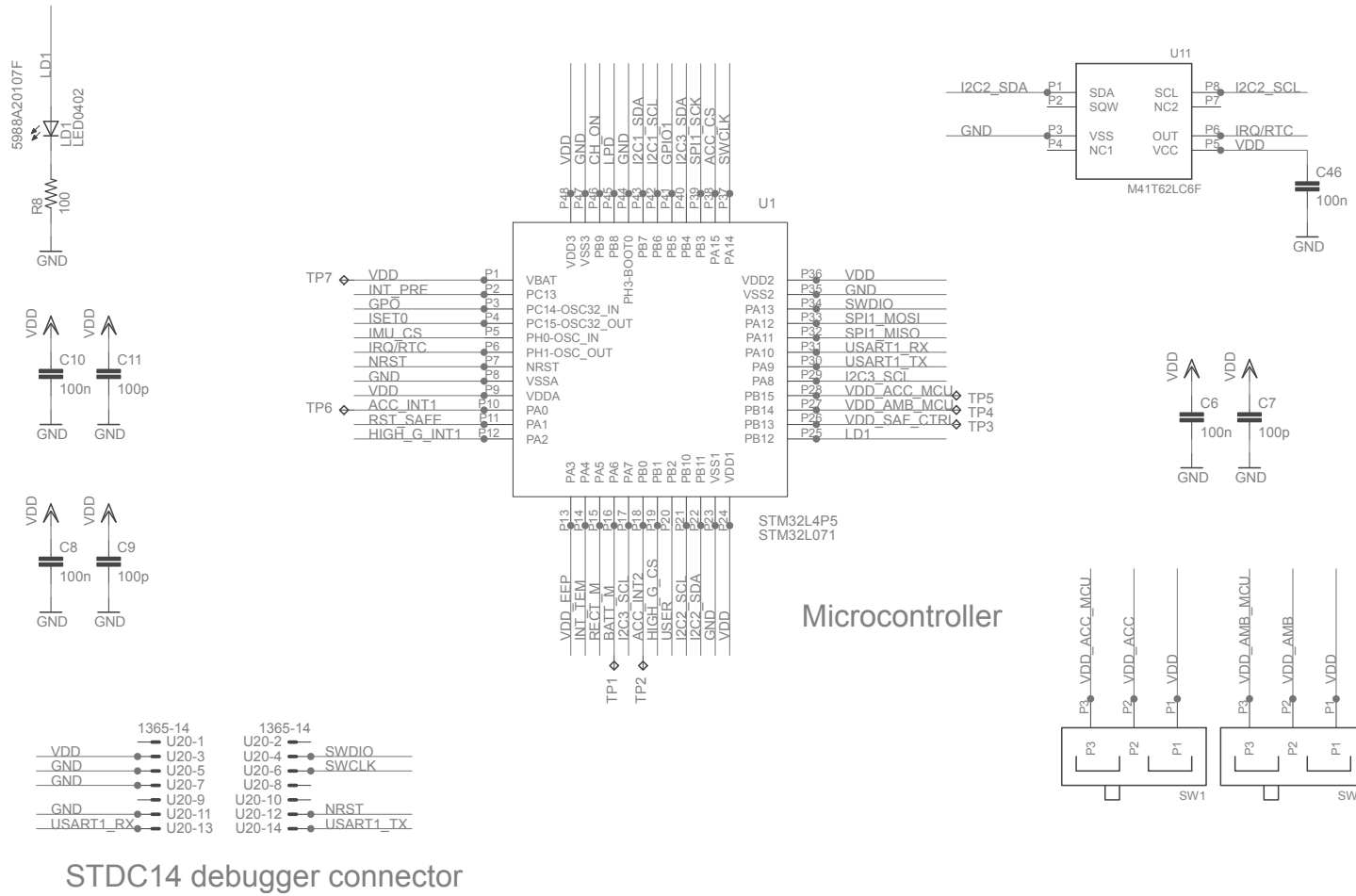

Figure 2. STEVAL-SMARTAG2 circuit schematic (2 of 6)

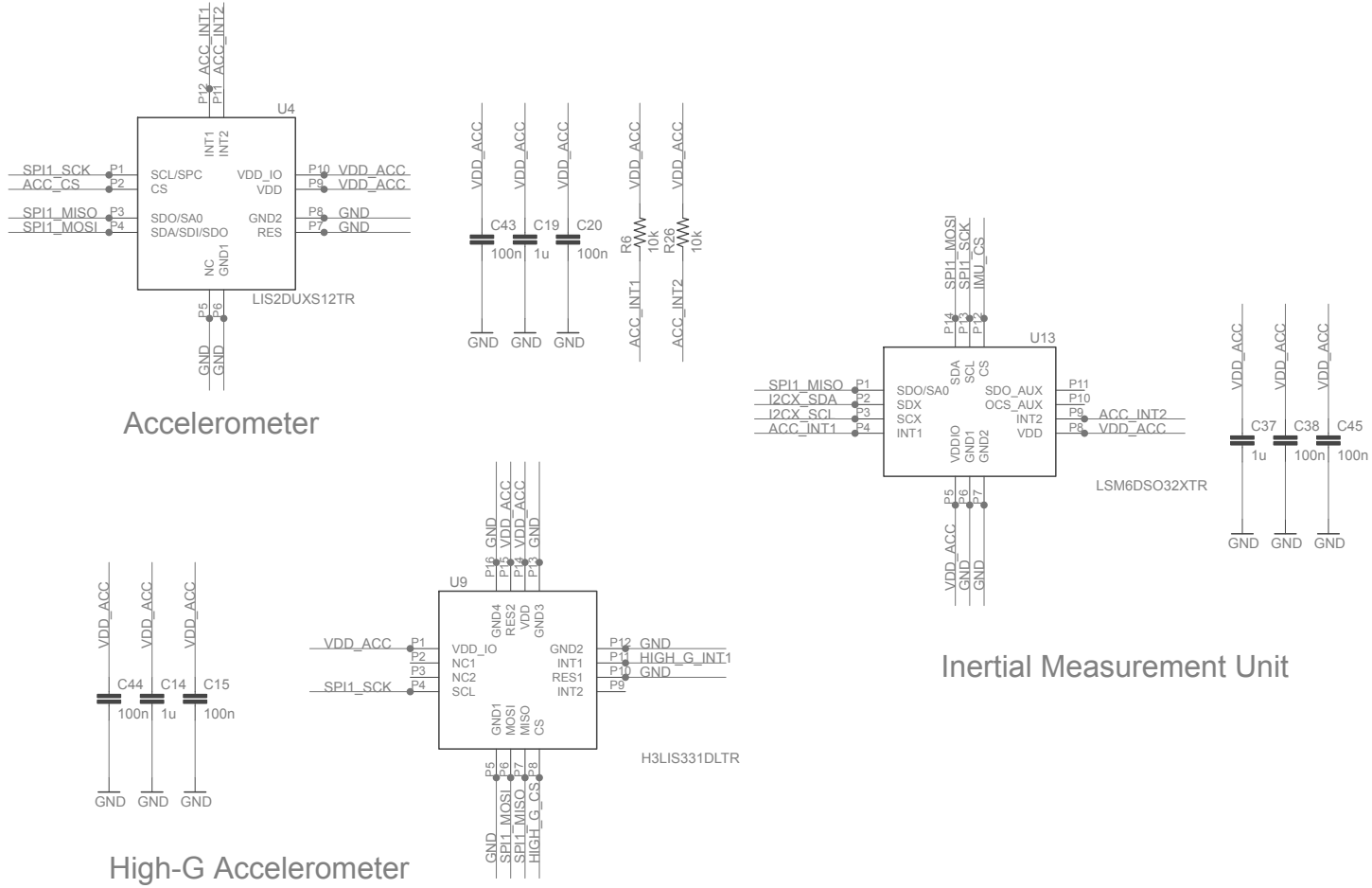

Figure 3. STEVAL-SMARTAG2 circuit schematic (3 of 6)

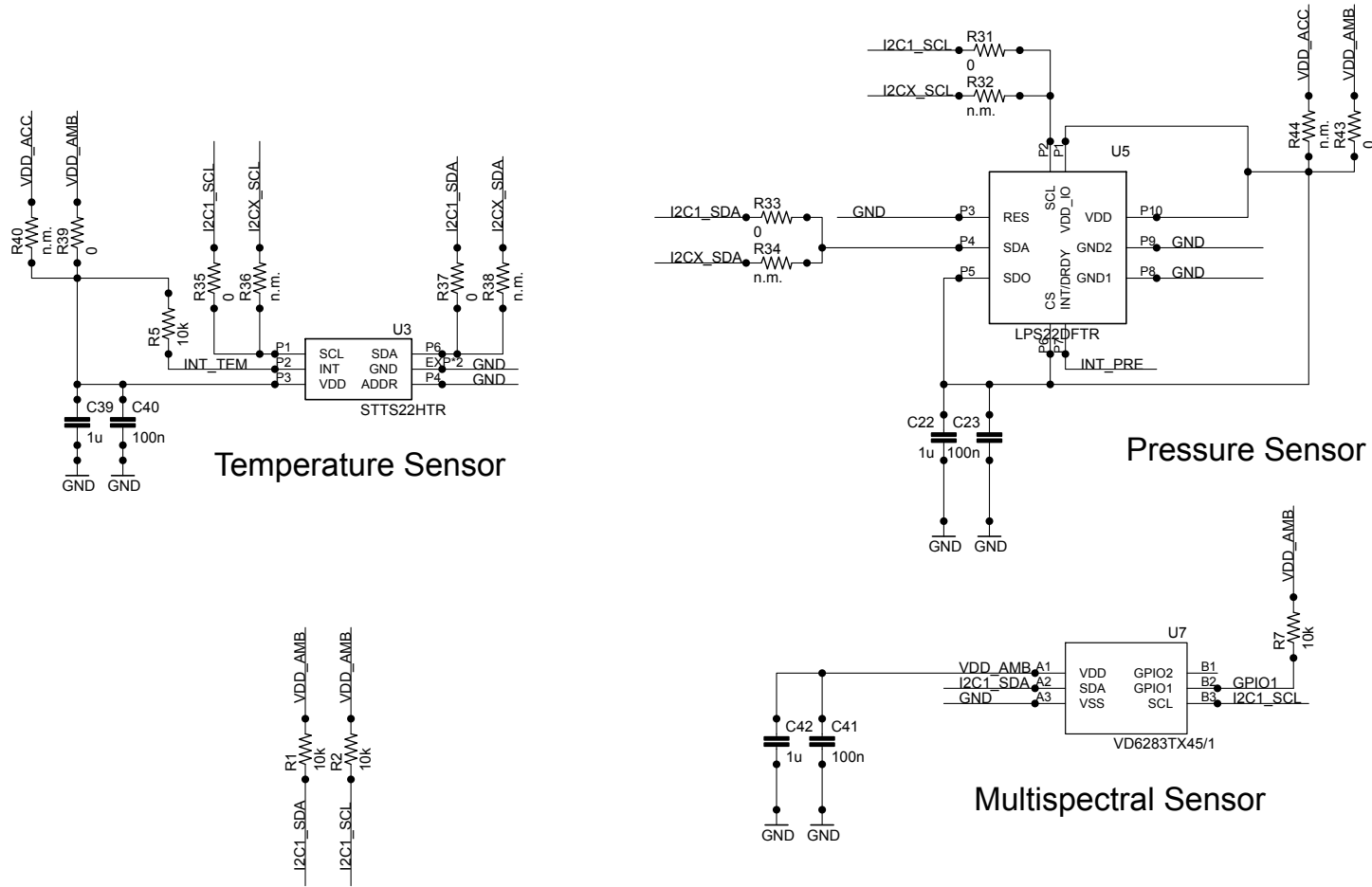
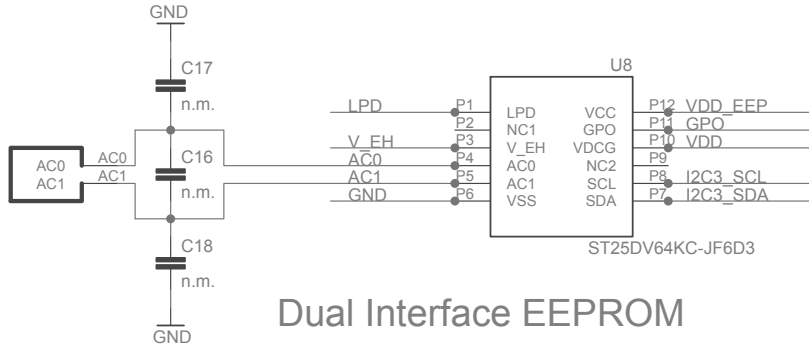
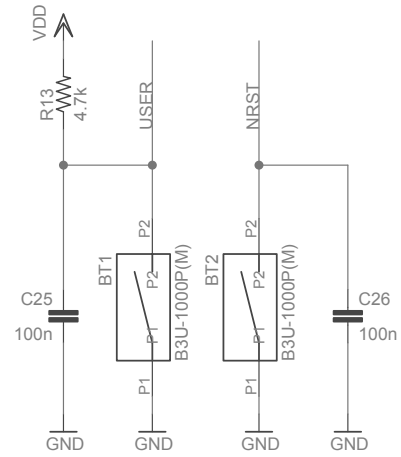
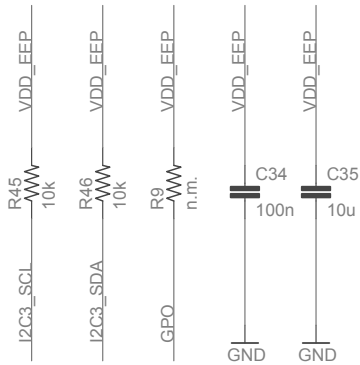

Figure 4. STEVAL-SMARTAG2 circuit schematic (4 of 6)



Dual Interface EEPROM



Push Buttons



Figure 5. STEVAL-SMARTAG2 circuit schematic (5 of 6)

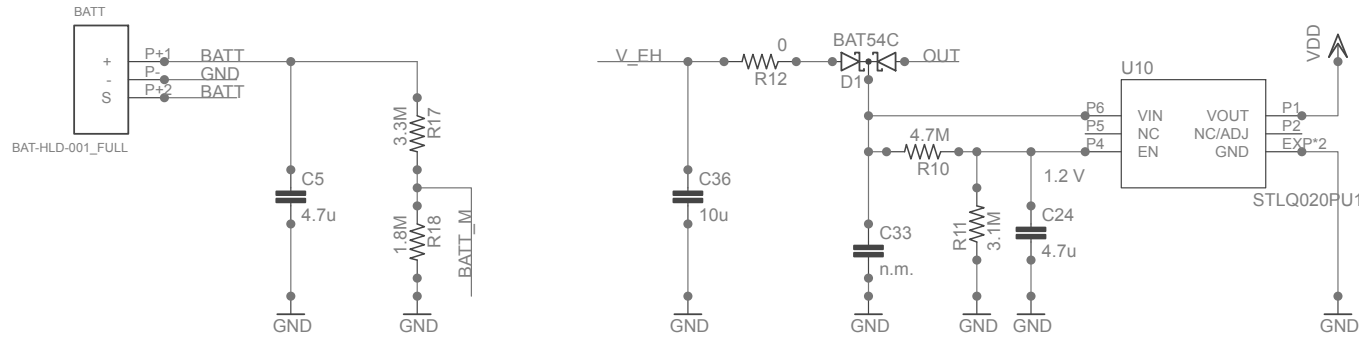

LIR2032 Battery

$$BATT\_M(v) = BATT * 0.353$$

Linear regulator (1.9 V)

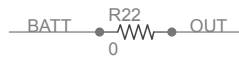

PAD3  
X I2C2\_SCL

PAD4  
X I2C2\_SDA

PAD5  
X VDD

PAD6  
X GND

PAD8  
X GND



Figure 6. STEVAL-SMARTAG2 circuit schematic (6 of 6)

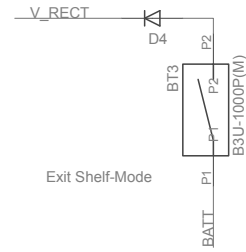
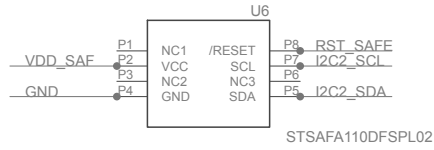
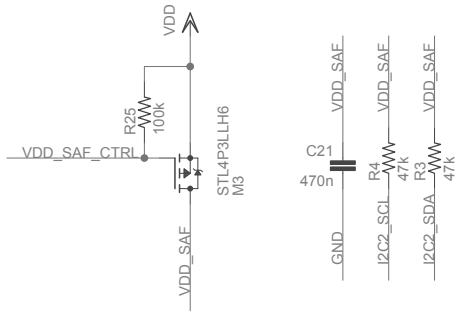
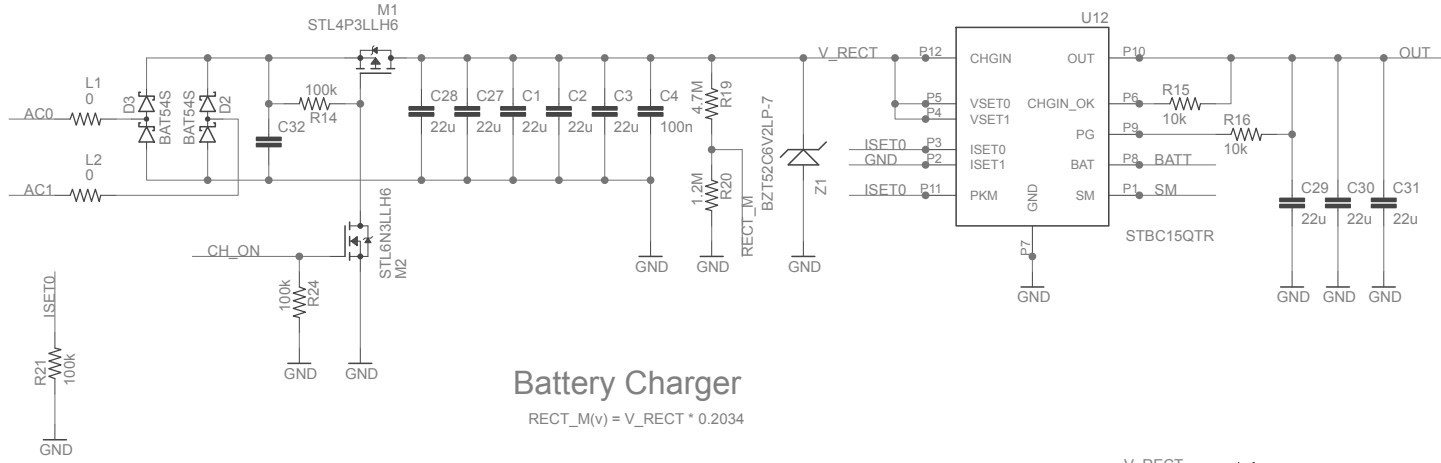



## 2 Board versions

**Table 1. STEVAL-SMARTAG2 versions**

| PCB version                      | Schematic diagrams                   | Bill of materials                   |
|----------------------------------|--------------------------------------|-------------------------------------|
| STEVAL\$SMARTAG2A <sup>(1)</sup> | STEVAL\$SMARTAG2A schematic diagrams | STEVAL\$SMARTAG2A bill of materials |

1. This code identifies the STEVAL-SMARTAG2 evaluation board first version. It is printed on the board PCB.

## Revision history

Table 2. Document revision history

| Date        | Revision | Changes          |
|-------------|----------|------------------|
| 09-Nov-2022 | 1        | Initial release. |