

Six-step brushless motor driver evaluation board for applications based on the STSPIN32F0B BLDC controller

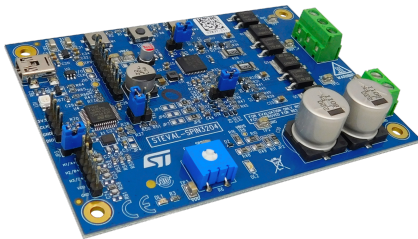

Features

- Input voltage from 7 to 45 V
- Output current up to 15 A_{RMS}
- Power stage based on [STD140N6F7](#) MOSFET
- Embedded 3.3 V buck regulator
- Embedded 12 V LDO regulator
- Single shunt current sensing
- Digital Hall sensors and encoder input
- Overcurrent comparator
- Bus voltage sensing
- Embedded ST-LINK/V2-1
- Easy user interface with buttons and trimmer
- RoHS and WEEE compliant

Applications

- Battery powered power tools
- Home appliances
- Pumps and fans
- Industrial automation

Product summary	
Motor driver evaluation board based on the STSPIN32F0B 3-phase BLDC controller	STEVAL-SPIN3204
N-channel 60 V, 3.1 mΩ typ., 80 A STripFET F7 Power MOSFET in a DPAK package	STD140N6F7
Advanced single shunt BLDC controller with embedded STM32 MCU	STSPIN32F0B
Mainstream ARM Cortex-M0 Access line MCU with 32 Kbytes Flash, 48 MHz CPU, motor control	STM32F031C6
STM32 Motor Control SDK	X-CUBE-MCSDK-Y
Applications	Smart Home/ Industrial Motor Control/Industrial Tools

Description

The [STEVAL-SPIN3204](#) three-phase brushless DC motor driver board is based on the [STSPIN32F0B](#) 3-phase BLDC controller with triple half-bridge gate driver, single shunt resistor current sensing topology and programmable overcurrent protection.

The motor controller system-in-package includes an [STM32F031C6](#) microcontroller ready to execute 6-step, field oriented control (FOC) and other advanced driving algorithms in the firmware, which can be downloaded onto the chip flash memory via the board USB port.

The board is designed to help you test and develop motor control designs for applications such as power tools, home appliances, fans and pumps, with a flexible evaluation platform that even allows you to toggle between external sensor and sensorless position feedback data methods.

1 Solution overview

The STEVAL-SPIN3204 motor control board can be set up to control a three-phase brushless DC (BLDC) motor based on position feedback data from one of the following sources:

- external quadrature encoders or Hall Effect sensors
- on-board circuitry that senses the back electromotive force (BEMF) generated by the load motor.

Figure 1. STEVAL-SPIN3204 motor control block diagram

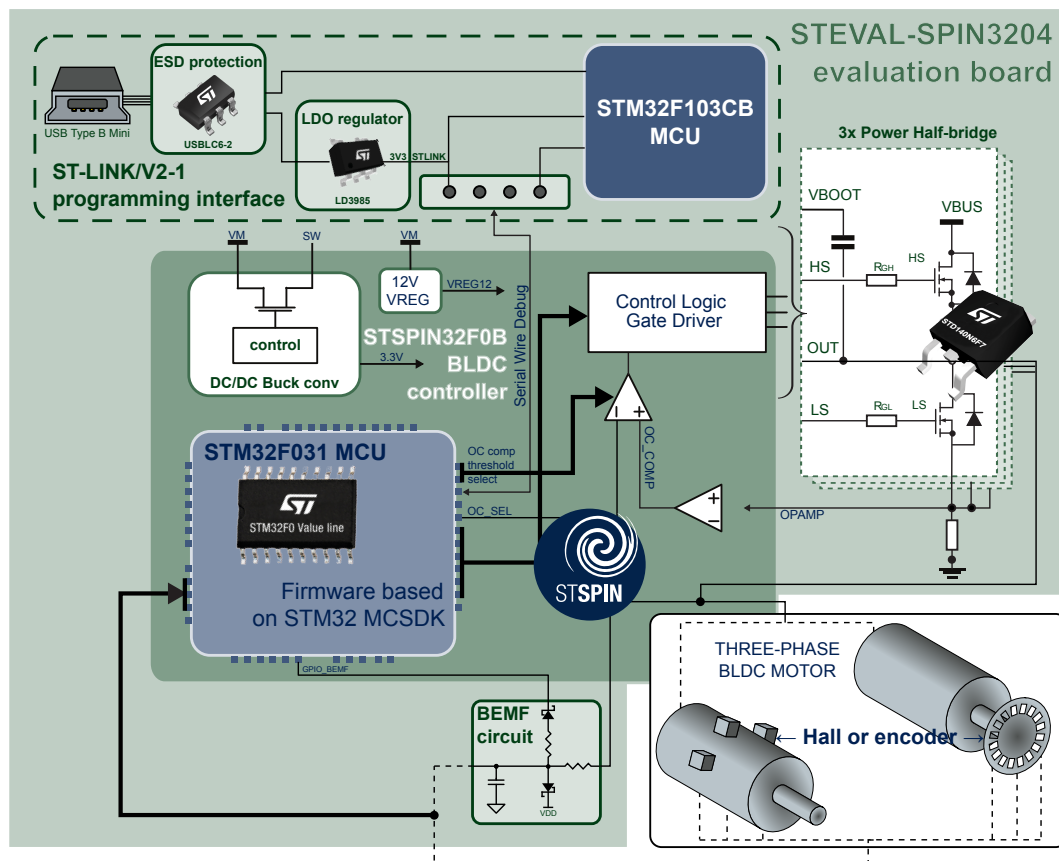

The power stage on the board delivers 15 A_{RMS} DC current from three STD140N6F7 MOSFETs in half-bridge configuration managed by the triple half-bridge gate driver on the BLDC controller.

The board senses the current flowing into the motor phases through a shunt resistor, and the resulting signal is amplified, filtered and forwarded to the STSPIN32F0B BLDC controller MCU and control logic gate driver for monitoring and peak current limitation or overcurrent protection, depending on the driving method implemented in the firmware (voltage mode or current mode, respectively). Voltage sensing is implemented through a voltage divider from the motor supply voltage (VBUS) and sent to the BLDC controller MCU for monitoring purposes.

The board also features an embedded ST-LINK/V2-1 programmer/debugger to help you load, test and modify the motor controller firmware.

2 Schematic diagrams

Figure 2. STEVAL-SPIN3204 schematic - motor controller MCU and interfaces

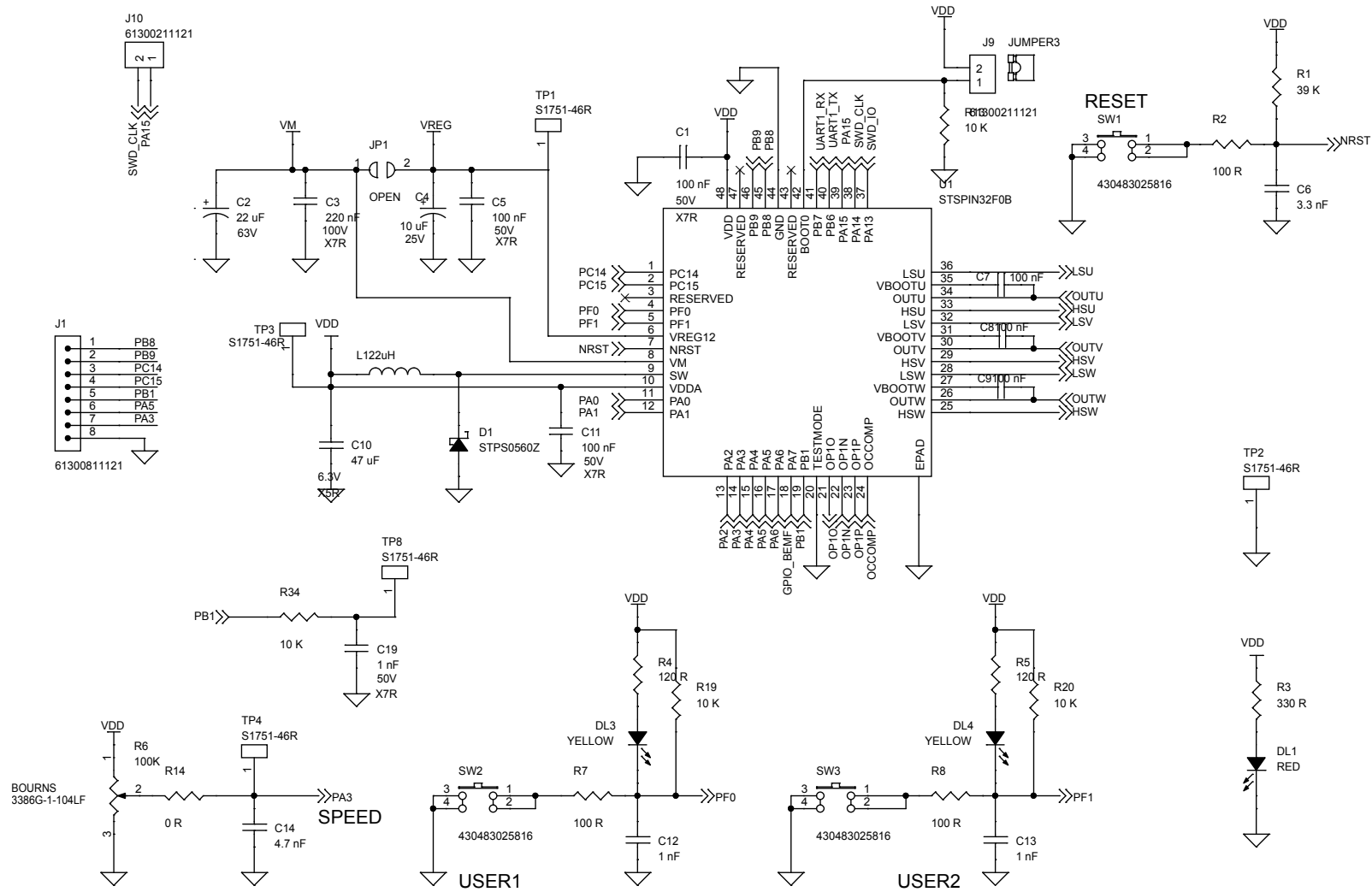

Figure 3. STEVAL-SPIN3204 schematic - power stage and external sensor inputs

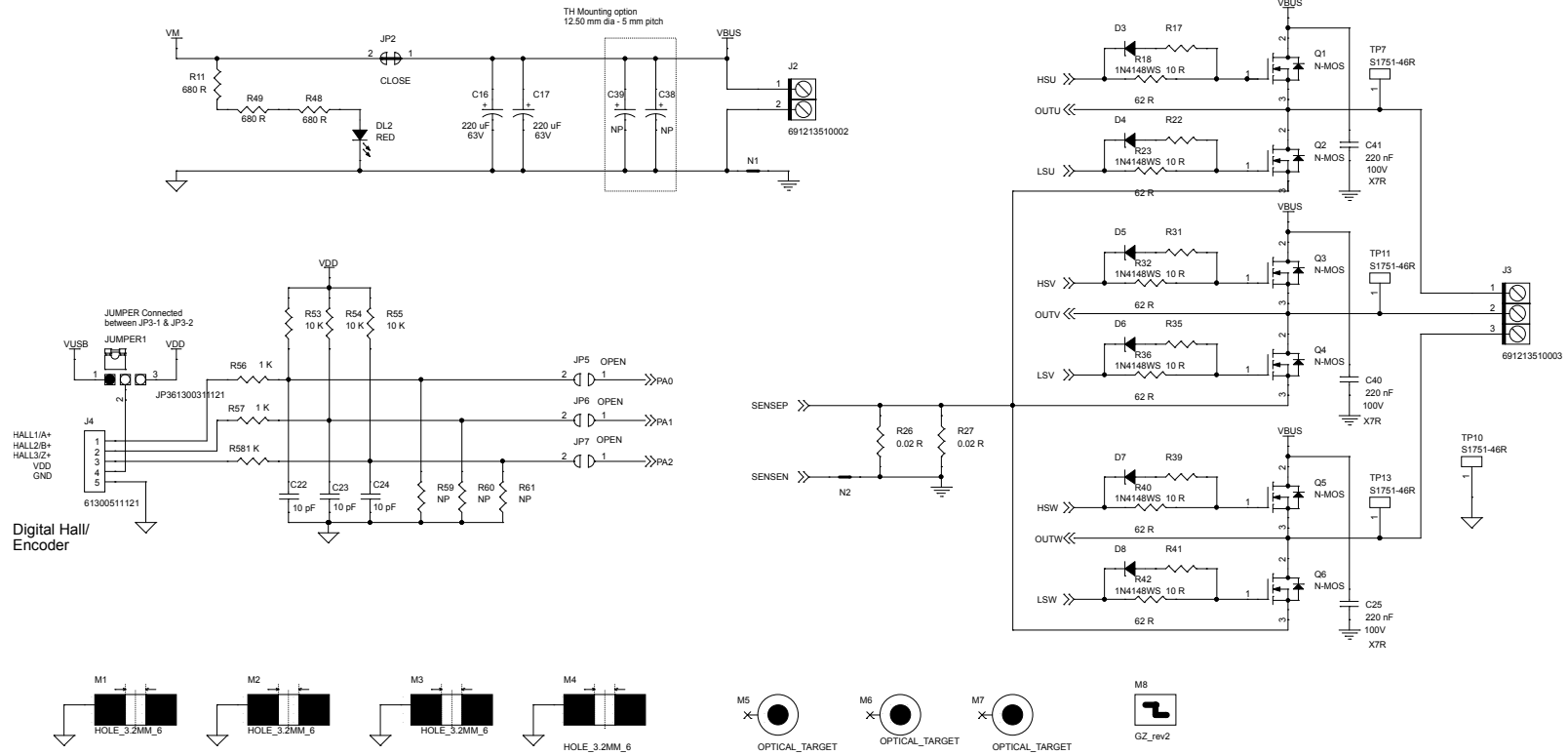

Figure 4. STEVAL-SPIN3204 schematic - current and voltage feedback, and BEMF sensing circuits

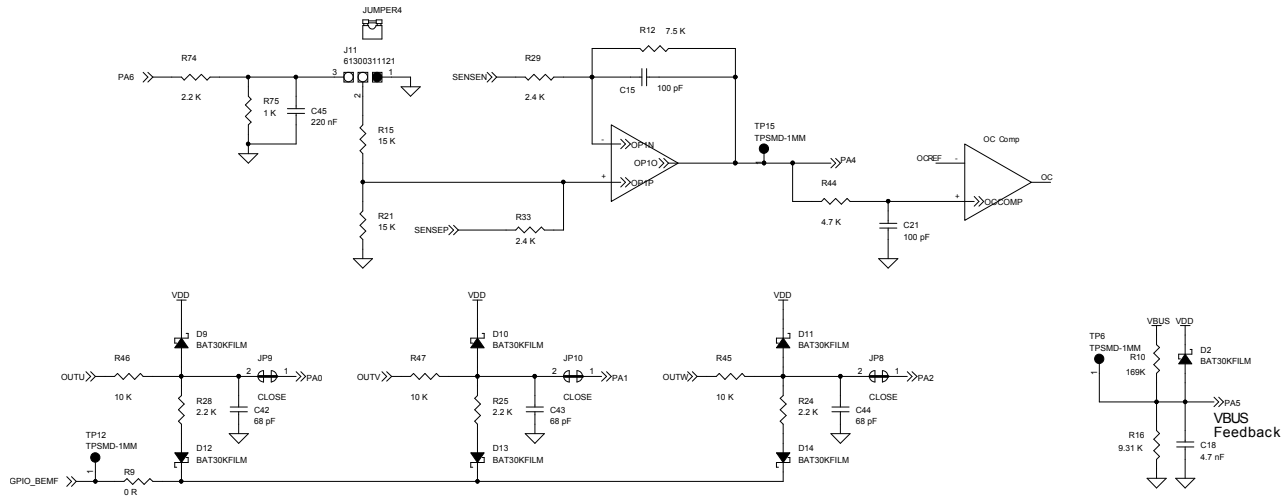
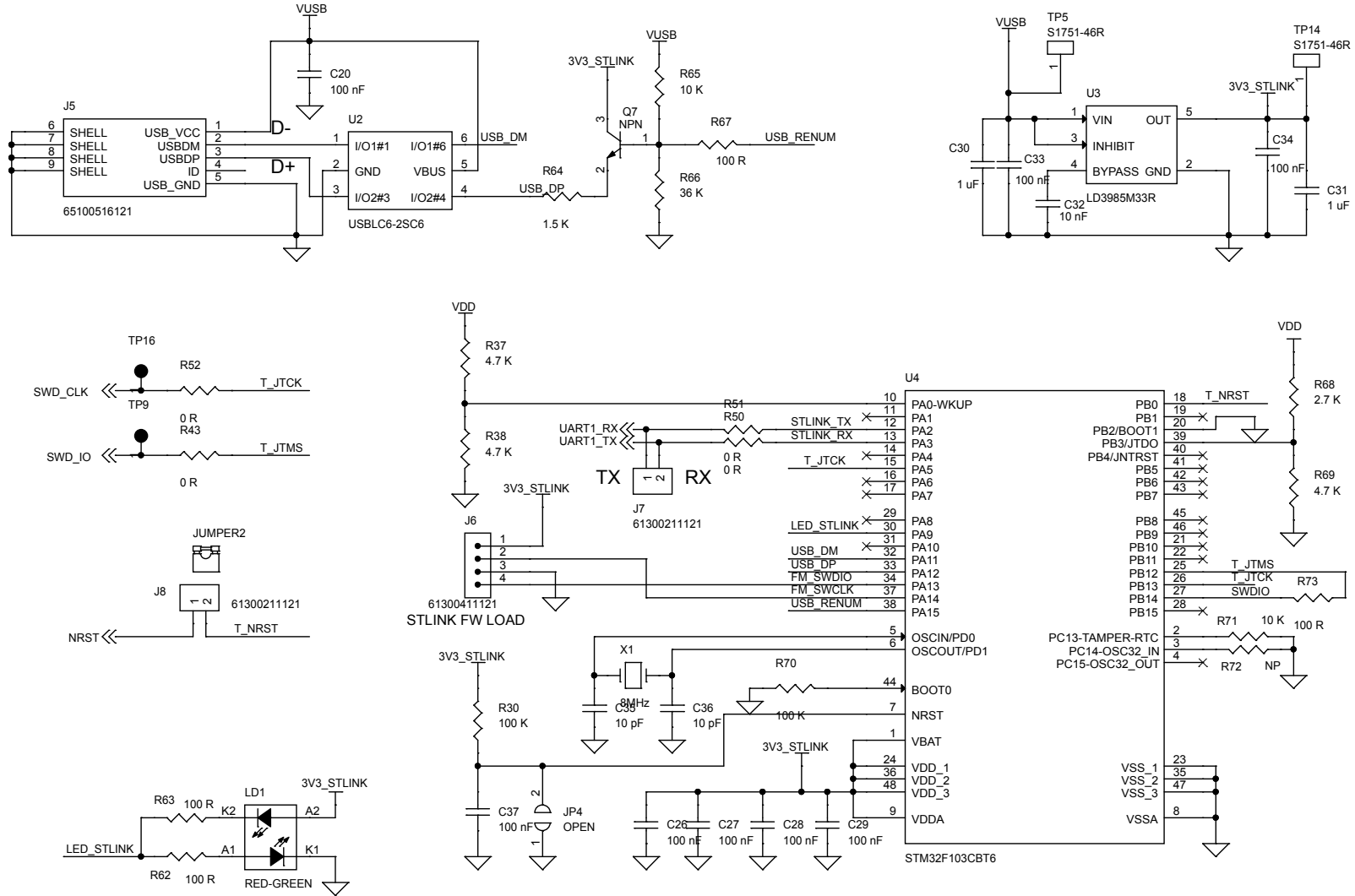

Figure 5. STEVAL-SPIN3204 schematic - ST-LINK



Revision history

Table 1. Document revision history

Date	Version	Changes
06-May-2019	1	Initial release.
19-Jul-2021	2	Updated cover page product summary table and Section 1 Solution overview . Added references to X-CUBE-MCSDK-Y.