

STWIN SensorTile Wireless Industrial Node development kit and reference design for industrial IoT applications

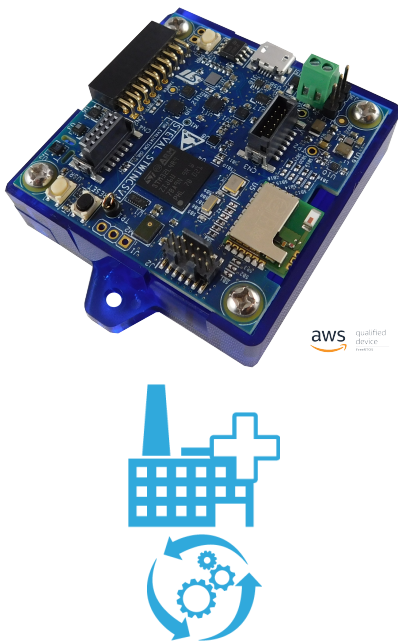

Features

- Multi-sensing wireless platform implementing vibration monitoring and ultrasound detection
- Updated version of STEVAL-STWINKT1, now including STSAFE-A110 populated, BlueNRG-M2SA module and IMP23ABSU MEMS microphone
- Built around STWIN core system board with processing, sensing, connectivity and expansion capabilities
- Ultra-low-power ARM Cortex-M4 MCU at 120 MHz with FPU, 2048 kbytes Flash memory (STM32L4R9)
- Micro SD Card slot for standalone data logging applications
- On-board Bluetooth® low energy v5.0 wireless technology and Wi-Fi (with STEVAL-STWINWFV1 expansion board), and wired RS485 and USB OTG connectivity
- Option to implement Authentication and Brand protection secure solution with STSAFE-A110
- Wide range of industrial IoT sensors:
 - ultra-wide bandwidth (up to 6 kHz), low-noise, 3-axis digital vibration sensor (IIS3DWB)
 - 3D accelerometer + 3D Gyro iNEMO inertial measurement unit (ISM330DHCX) with machine learning core
 - ultra-low-power high performance MEMS motion sensor (IIS2DH)
 - ultra-low-power 3-axis magnetometer (IIS2MDC)
 - digital absolute pressure sensor (LPS22HH)
 - relative humidity and temperature sensor (HTS221)
 - low-voltage digital local temperature sensor (STTS751)
 - industrial grade digital MEMS microphone (IMP34DT05)
 - analog MEMS microphone with frequency response up to 80 kHz (IMP23ABSU)
- Modular architecture, expandable via on-board connectors:
 - STMOD+ and 40-pin flex general purpose expansions
 - 12-pin male plug for connectivity expansions
 - 12-pin female plug for sensing expansions
- Other kit components:
 - Li-Po battery 480 mAh
 - STLINK-V3MINI debugger with programming cable
 - Plastic box

Product summary	
STWIN SensorTile Wireless Industrial Node development kit and reference design for industrial IoT applications	STEVAL-STWINKT1B
Firmware for STEVAL-STWINKT1B evaluation kit	STSW-STWINKT01
Ultra-low-power ARM Cortex-M4 MCU with FPU	STM32L4R9ZIJ6
iNEMO inertial module with machine learning core and finite state machine with digital output for industrial applications	ISM330DHCX
Ultra-wide bandwidth (up to 6 kHz), low-noise, 3-axis digital vibration sensor	IIS3DWB

Description

The STWIN SensorTile wireless industrial node (STEVAL-STWINKT1B) is a development kit and reference design that simplifies prototyping and testing of advanced industrial IoT applications such as condition monitoring and predictive maintenance.

Product summary	
Firmware debug and update interface	STLINK-V3MINI debugger
Applications	IoT for Smart industry Condition Monitoring and Predictive Maintenance Industrial Sensors

The kit features a core system board with a range of embedded industrial-grade sensors and an ultra-low-power microcontroller for vibration analysis of 9-DoF motion sensing data across a wide range of vibration frequencies, including very high frequency audio and ultrasound spectra, and high precision local temperature and environmental monitoring.

The development kit is complemented with a rich set of software packages and optimized firmware libraries, as well as a cloud dashboard application, all provided to help speed up design cycles for end-to-end solutions.

The kit supports Bluetooth® low energy wireless connectivity through an on-board module, and Wi-Fi connectivity through a special plugin expansion board (STEVAL-STWINWFV1). Wired connectivity is also supported via an on-board RS485 transceiver. The core system board also includes an STMod+ connector for compatible, low cost, small form factor daughter boards associated with the STM32 family, such as the LTE Cell pack.

Apart from the core system board, the kit is provided complete with a 480 mAh Li-Po battery, an STLINK-V3MINI debugger and a plastic box.

1 Application overview

Predictive maintenance applications collect and process data from a wide variety of sensors in order to identify potential failures in machinery before they happen. A principal requirement of such applications is that the condition monitoring equipment is placed very close to relevant machine componentry for the data to be reliable, which is why the STWIN node is designed to be small but robust, self-powered and capable of wireless communication.

Another application issue is the high volumes of preferably real-time data processing involved, which can overwhelm centralized monitoring and control systems, and corresponding communication networks. Distributed (or decentralized) computing architectures represent a valid solution to this problem by performing data pre-processing and analytical operations directly on the node. The STWIN kit supports and can demonstrate this concept through sample applications in the firmware package running on the STM32L4+ ultra-low-power microcontroller embedded on the core system board.

Figure 1. STEVAL-STWINKT1B functional block diagram

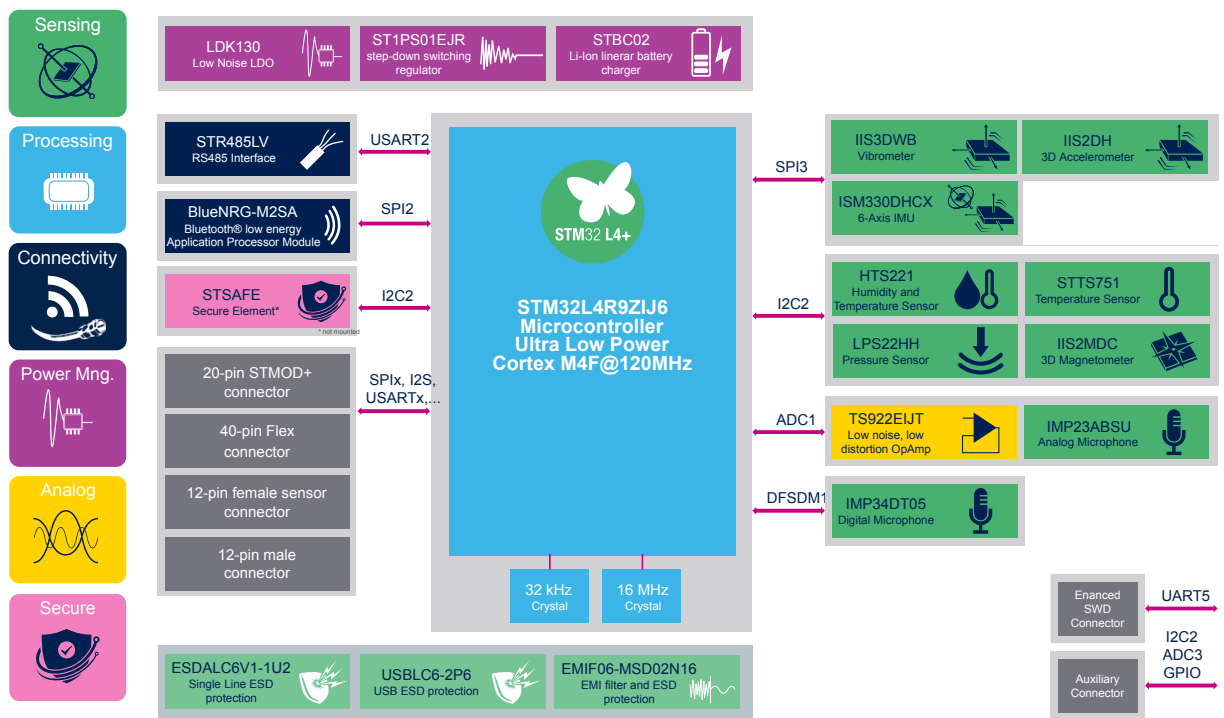

Finally, the actual sensing equipment can be subject to a very wide range of low frequency (imbalance or misalignment), medium frequency (worn gears or bearings) and high frequency (worn cooling fan bearings) vibrations, which is why our node carries several high performance accelerometers, IMUs and magnetometers, capable of detecting movement along 9 axes to a very high degree of sensitivity. For very high frequencies in the order of tens of kilohertz, vibration analysis is covered by sound and ultrasound applications based on data coming from a digital microphone and a high performance analog microphone, respectively.

2 Schematic diagrams

Figure 2. STEVAL-STWINKT1B schematic (1 of 7)

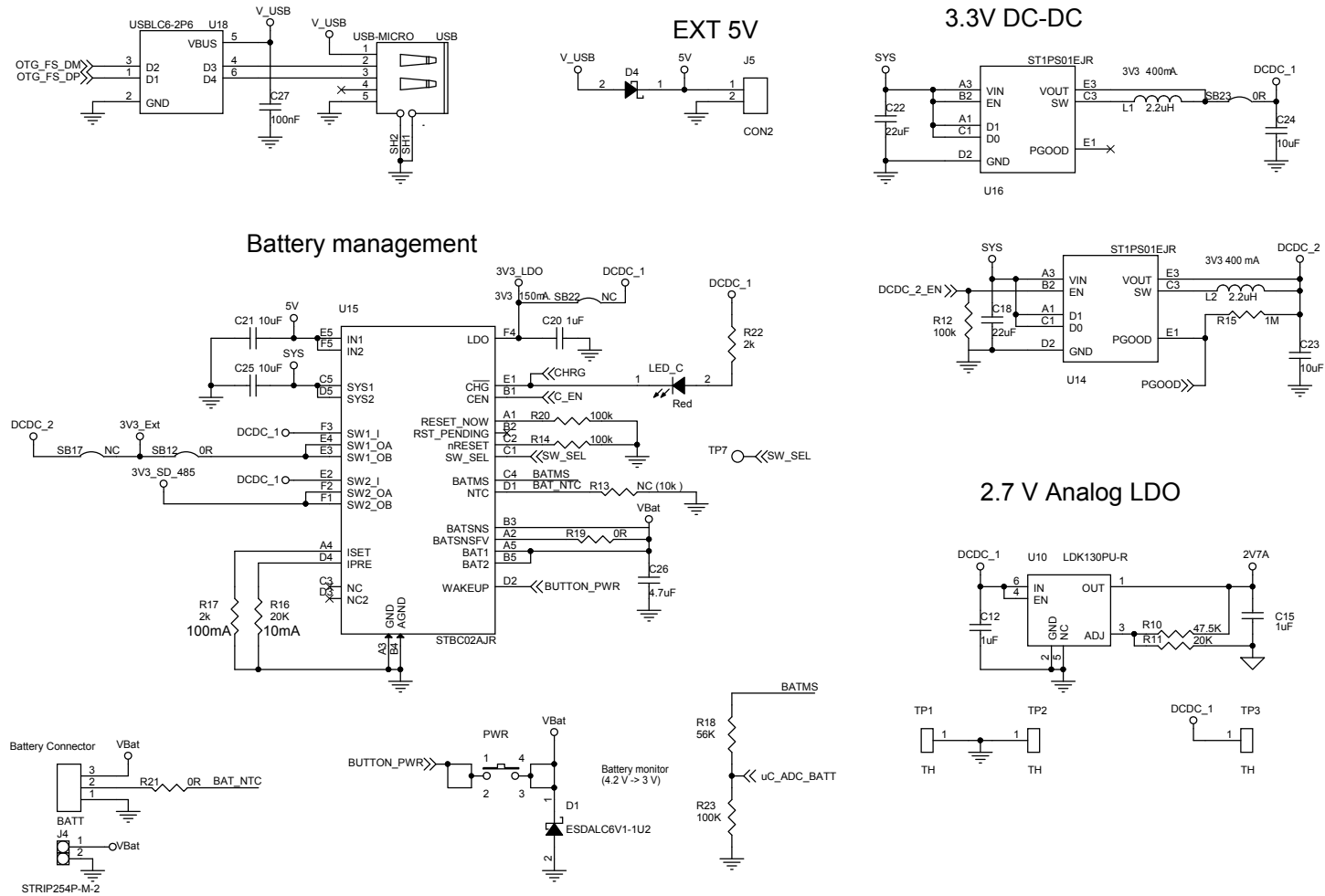

Figure 3. STEVAL-STWINKT1B schematic (2 of 7)

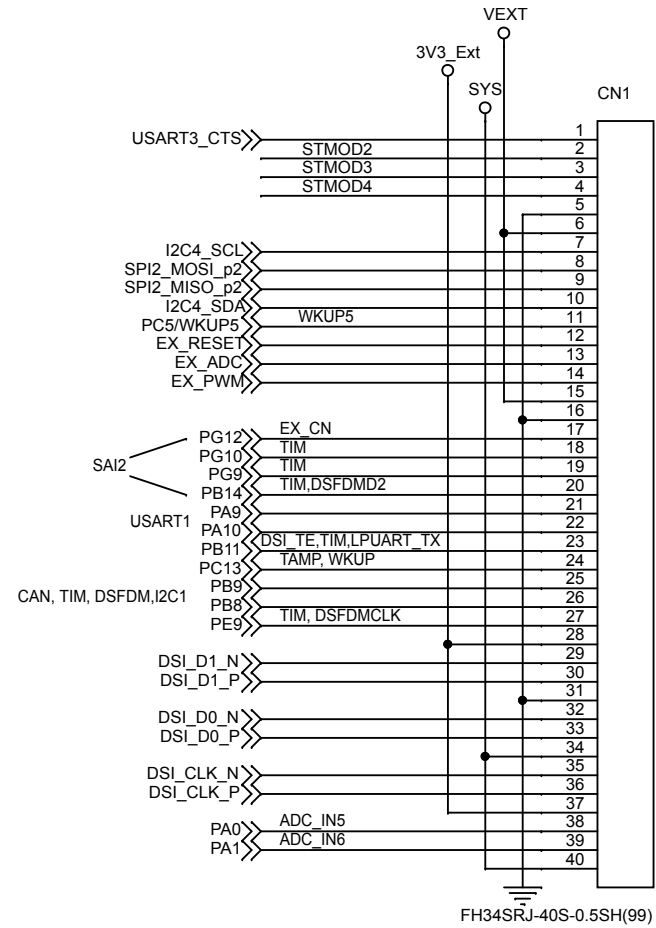
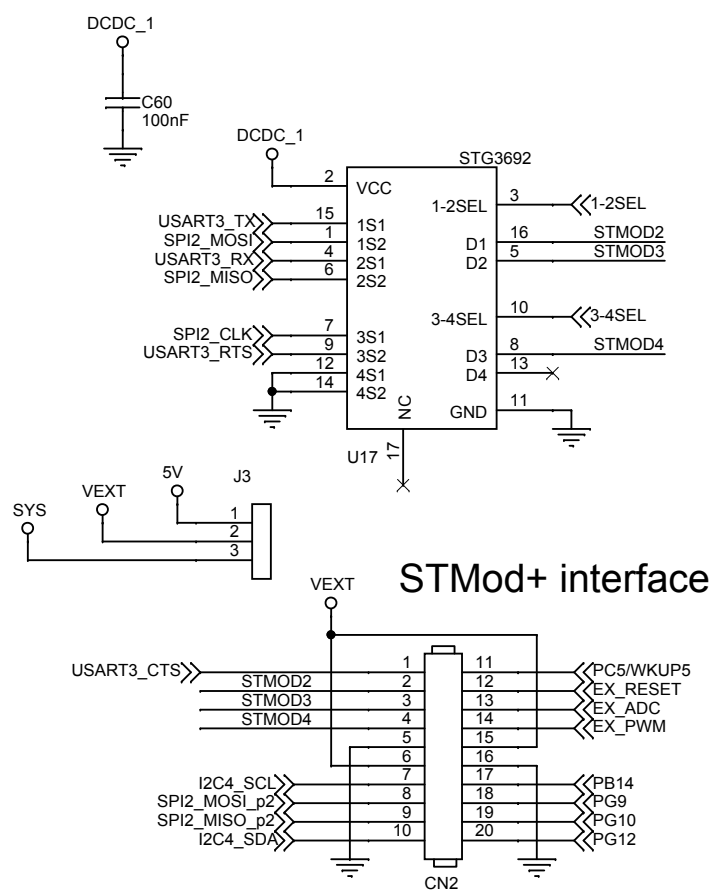

Figure 4. STEVAL-STWINKT1B schematic (3 of 7)

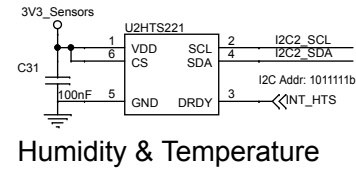
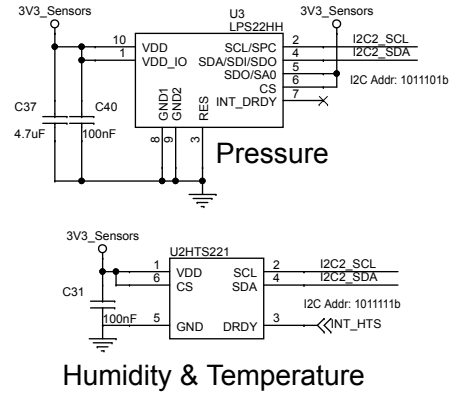
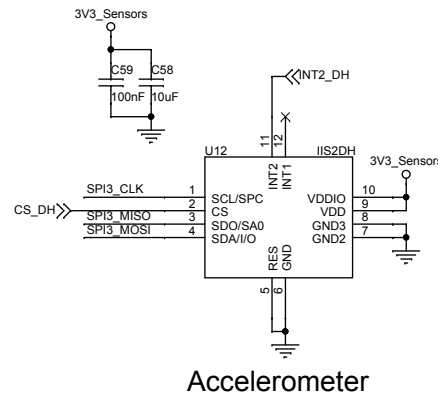
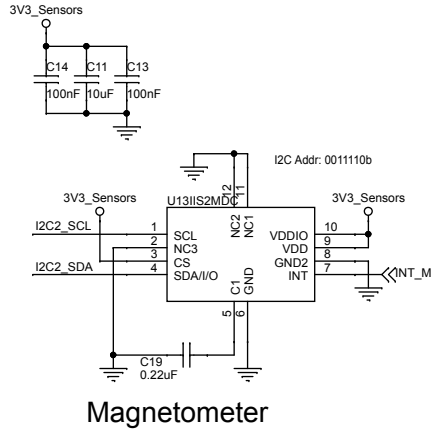
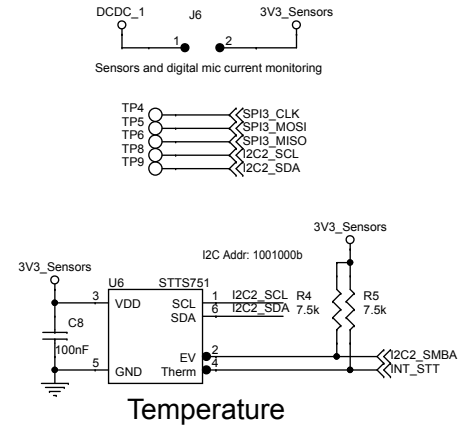
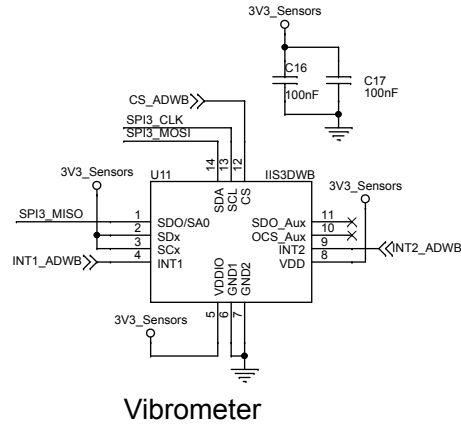
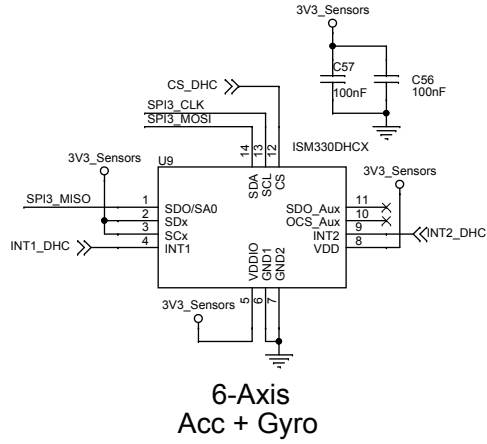

Figure 5. STEVAL-STWINKT1B schematic (4 of 7)

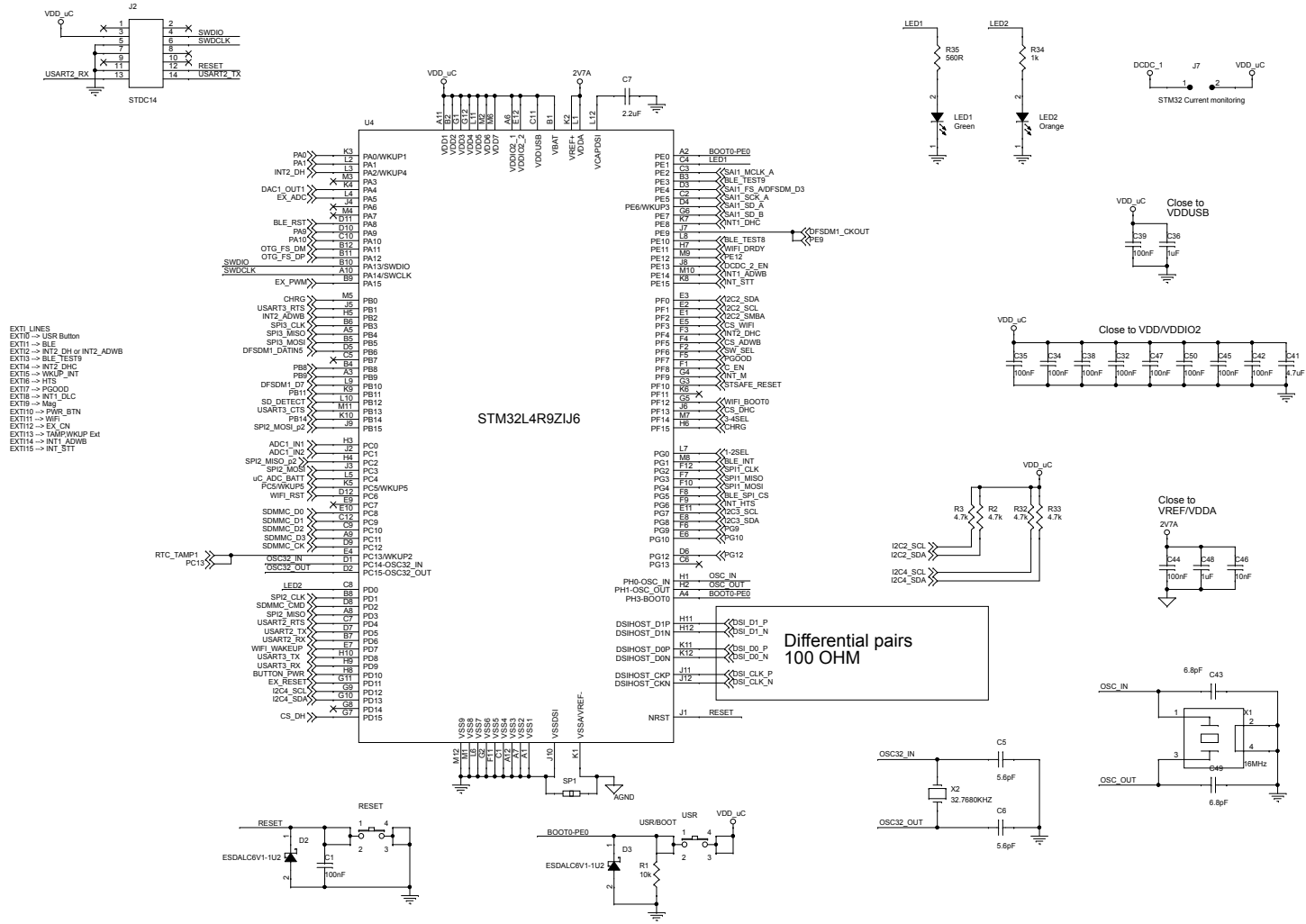

Figure 6. STEVAL-STWINKT1B schematic (5 of 7)

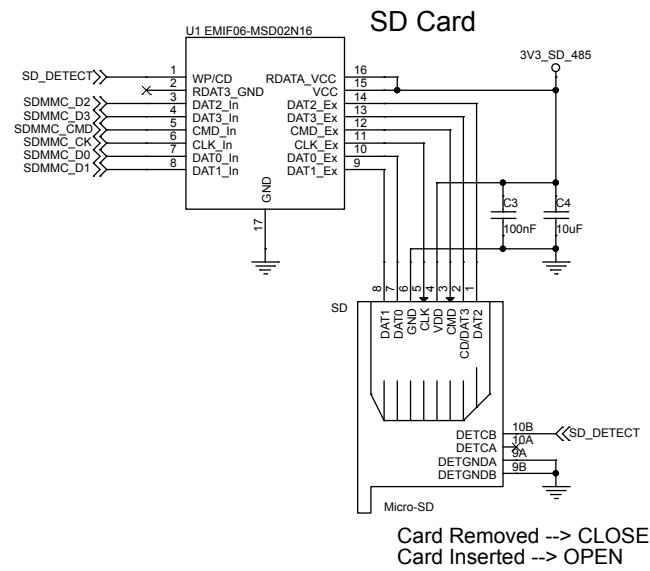
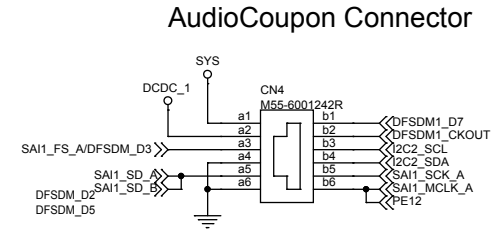
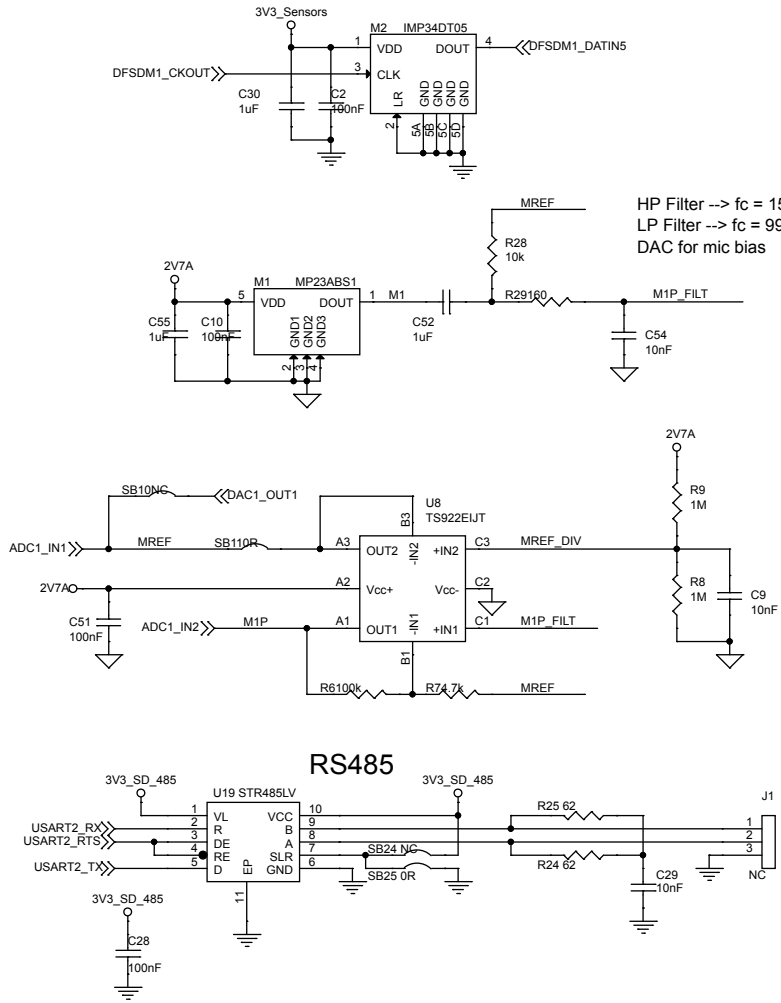

Figure 7. STEVAL-STWINKT1B schematic (6 of 7)

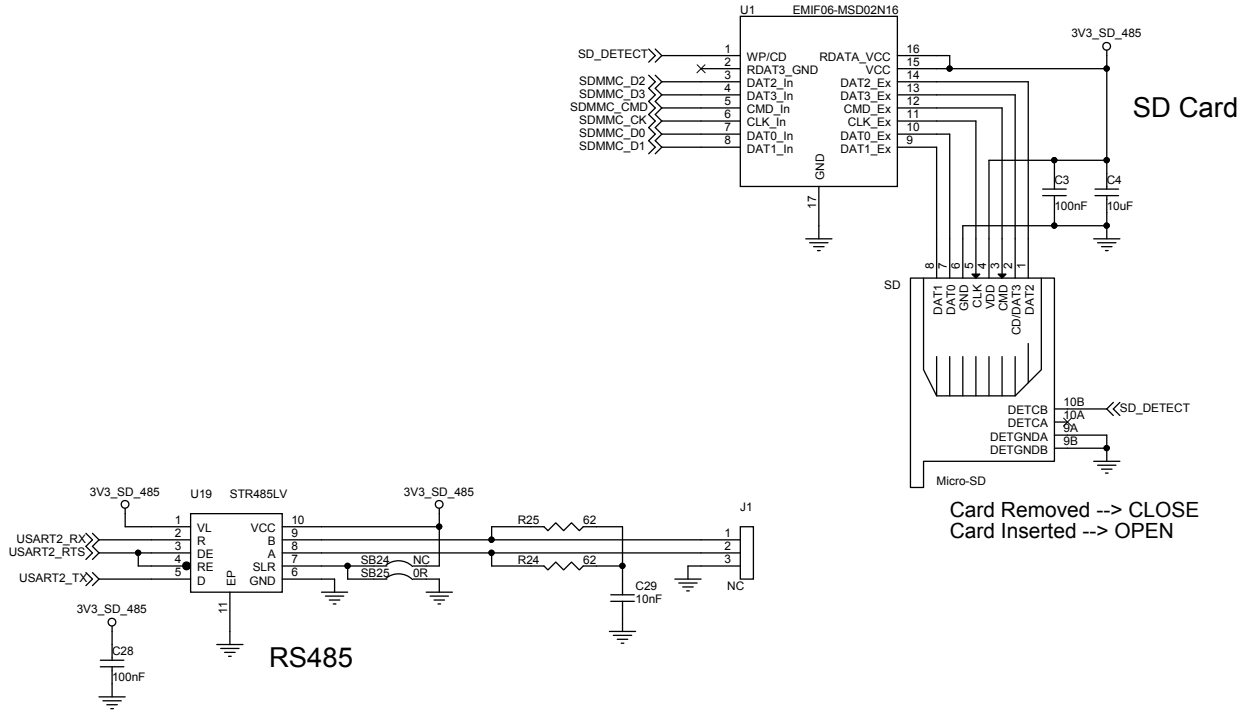
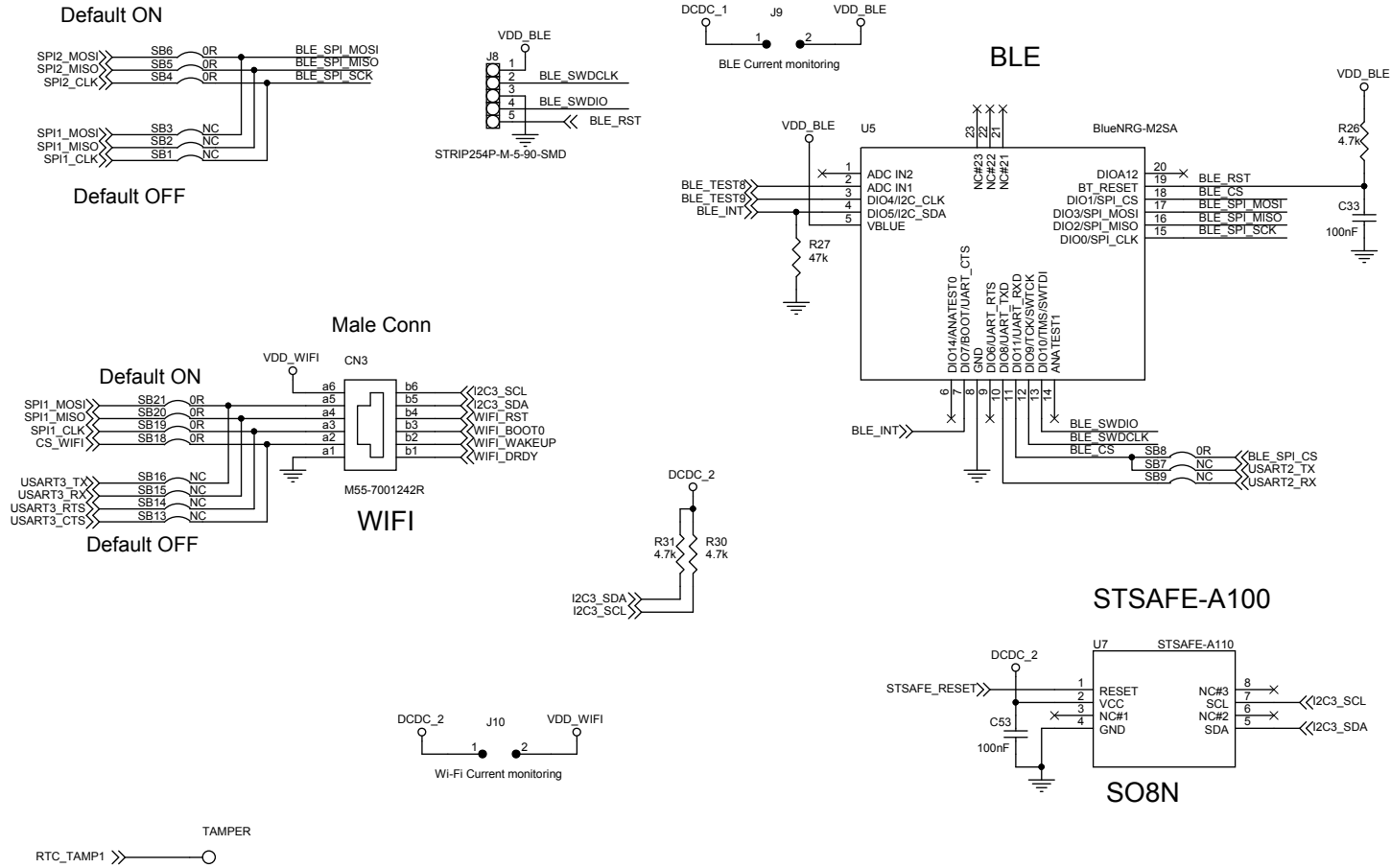

Figure 8. STEVAL-STWINKT1B schematic (7 of 7)



Revision history

Table 1. Document revision history

Date	Version	Changes
16-Nov-2020	1	Initial release.
15-Dec-2020	2	Updated cover page features and description.
01-Dec-2021	3	Updated document title.
02-Dec-2021	4	Updated document title.