

## Wi-Fi expansion for the SensorTile Wireless Industrial Node (STWIN) kit

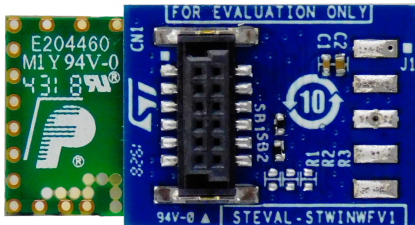

### Features

- Wi-Fi adapter for [STEVAL-STWINKT1B](#) (and [STEVAL-STWINKT1](#))
- Plugs into STWIN core system board through dedicated 12-pin connector
- Single 3.3 V power supply input
- ISM43362-M3G-L44-E Wi-Fi module:
  - 802.11 b/g/n Compatible based on Broadcom MAC/Baseband/Radio device
  - Fully contained TCP/IP stack
  - Host interface: SPI up to 25 MHz
  - Network features ICMP ( Ping), ARP, DHCP,TCP, UDP
  - Low power operation (3.3 V supply) with built-in low power modes
  - Secure Wi-Fi authentication WEP-128, WPA-PSK (TKIP), WPA2-PSK
  - CE certified
  - FCC certified
  - IC certified
- RoHS and China RoHS compliant
- WEEE compliant

### Description

The STEVAL-STWINWFV1 expansion board adds 2.4 GHz Wi-Fi connectivity to the [STEVAL-STWINKT1B](#) (and [STEVAL-STWINKT1](#)).

Application examples that take advantage of this expansion board can be found in [STSW-STWINKT01](#) firmware package as well as in the [FP-IND-PREDMNT1](#) Predictive Maintenance Function Pack.

Product summary	
Wi-Fi expansion board for the STWIN development kit	<a href="#">STEVAL-STWINWFV1</a>
STWIN SensorTile Wireless Industrial Node development kit and reference design for industrial IoT applications	<a href="#">STEVAL-STWINKT1/</a> <a href="#">STEVAL-STWINKT1B</a>
Firmware for <a href="#">STEVAL-STWINKT1B</a> evaluation kit	<a href="#">STSW-STWINKT01</a>
Applications	Factory Automation Connectivity

# 1 Schematic diagrams

Figure 1. STEVAL-STWINWFV1 schematic

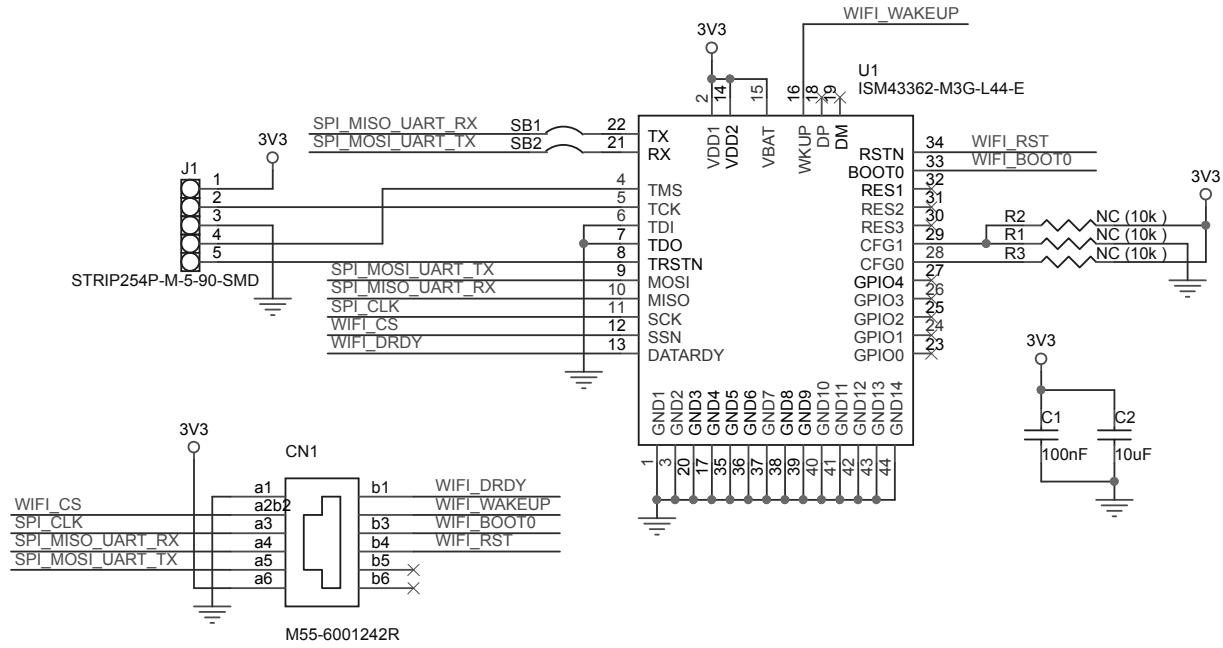

## Revision history

**Table 1. Document revision history**

Date	Version	Changes
29-Jul-2019	1	Initial release.
11-Jan-2021	2	Updated cover page features, description and product summary table.