

Motor driver evaluation board based on VNH5019A

Data brief

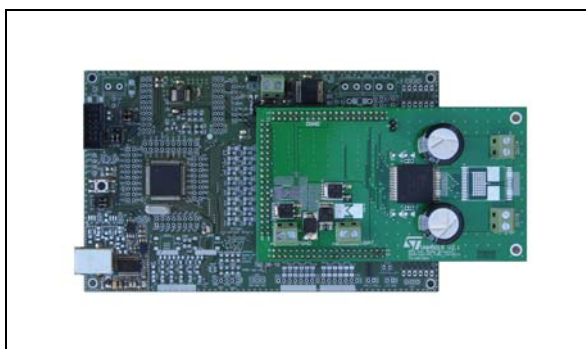

Description

STEVAL-VNH5019A offers dedicated power stage and controls suitable for electric DC motor driving. This evaluation board comes pre-assembled with VNH5019A H-bridge belonging to the VNH Motor Driver series based on VIPower® proprietary technology. Typical applications are Windows Lift, Sliding Door, Seat regulation.

This Evaluation Board consists of a motherboard (STM8 Universal Board) and a daughterboard.

The motherboard, based on STM8 microcontroller, provides the logic section for monitoring and driving the VNH5019A assembled in the daughterboard.

With the aim to make simpler the board usage and settings, ST provides a dedicated and user-friendly software with a Graphic User Interface (GUI). This enables the user to set VNH5019A parameters (PWM, Motor direction...) and at the same time it shows real time device diagnostic information like current output evolution, battery voltage monitoring, board temperature and much more.

Features

Type	$R_{DS(on)}$	I_{out}	$V_{CC(max)}$
VNH5019A-E	18 mΩ typ (per leg)	30 A	41 V

- Handling up to 30 A of maximum motor current output
- Undervoltage and overvoltage shutdown
- Device thermal protection
- Cross-conduction protection
- Very low standby power consumption
- Programmable PWM operation (up to 20 kHz)
- Protection against loss of ground and loss of V_{CC}
- Motor current monitoring (thanks to VNH5019A current sense output)
- On-board charge pump output for reverse polarity protection
- Device output protected against short to ground and short to V_{CC}
- Graphic User Interface (GUI)

Table 1. Device summary

Order code	Reference
STEVAL-VNH5019A	VNH5019A evaluation board



1 Application schematics and layouts

1.1 VNH5019A daughterboard

Figure 1. VNH5019A daughterboard top layer

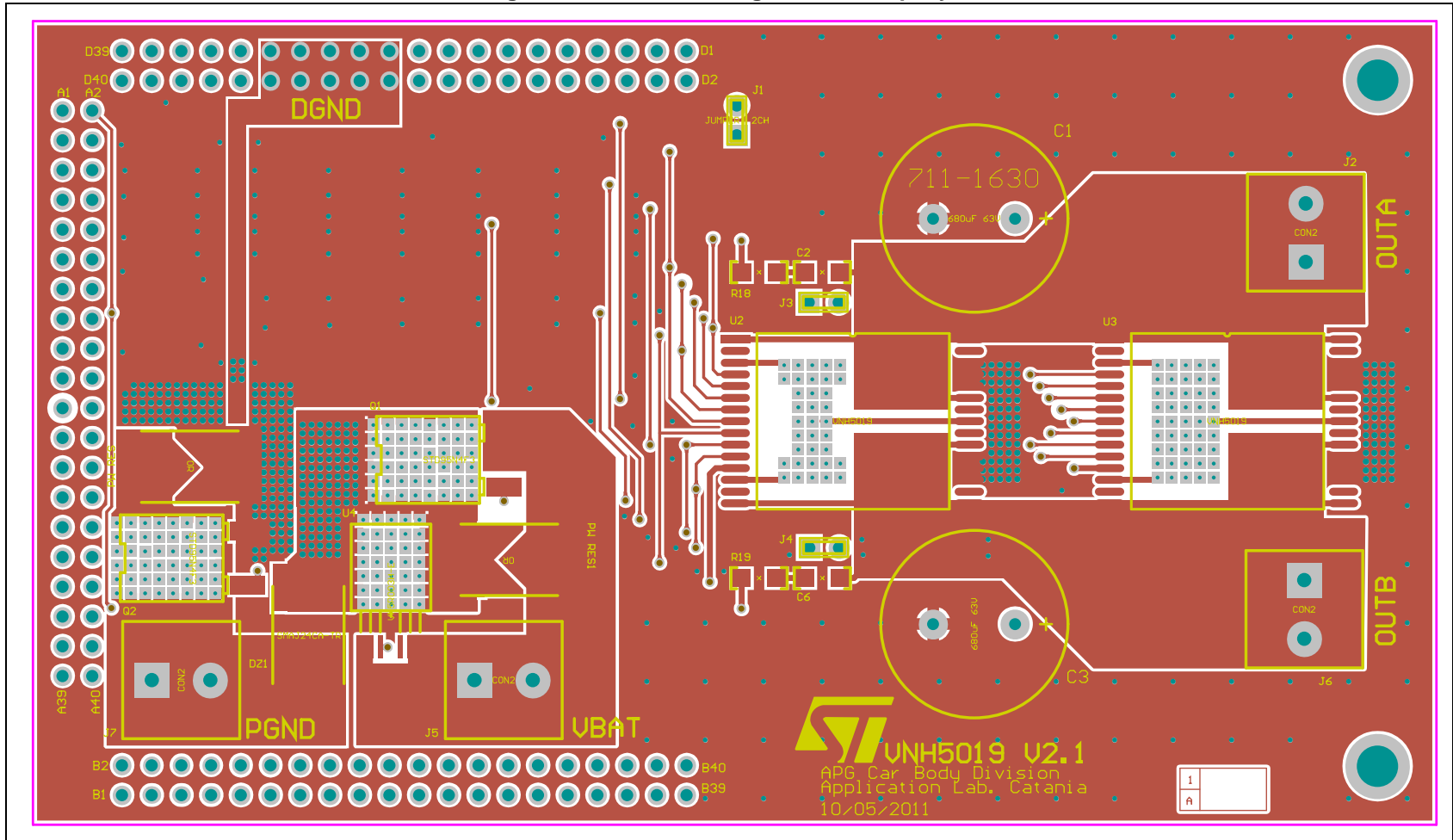

Figure 2. VNH5019A daughterboard bottom layer

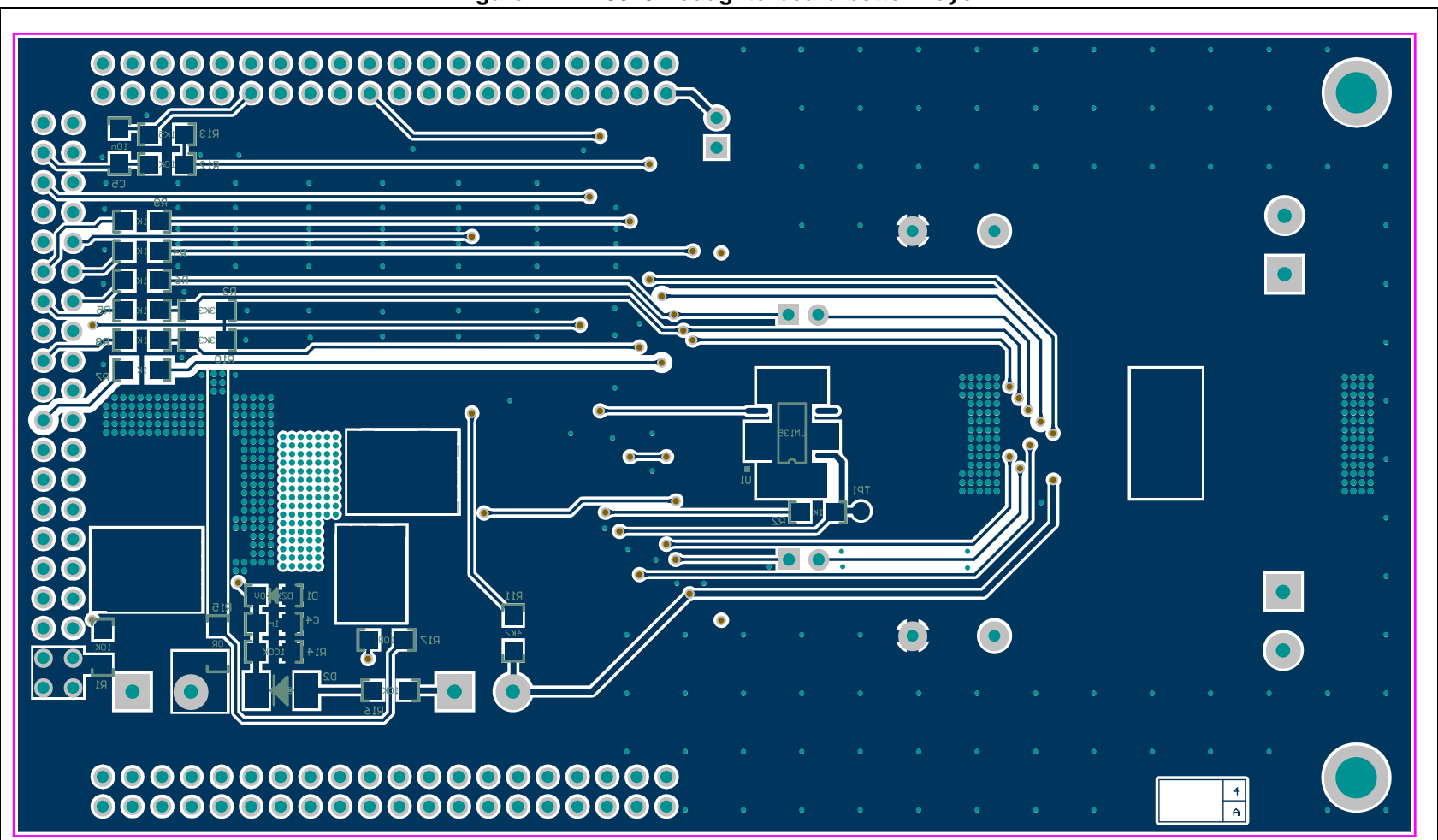

Figure 3. VNH5019A daughterboard application schematic (part 1)

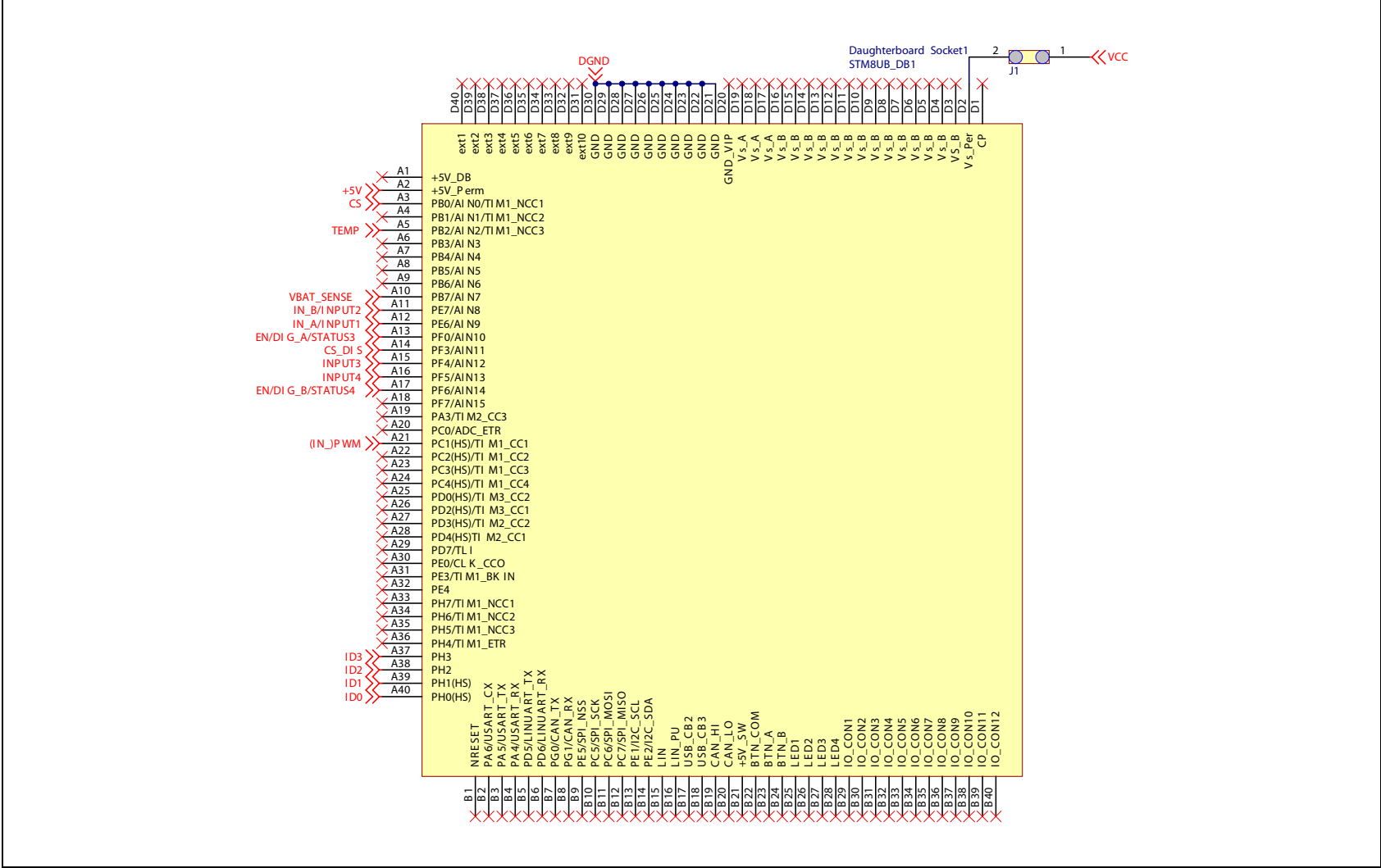
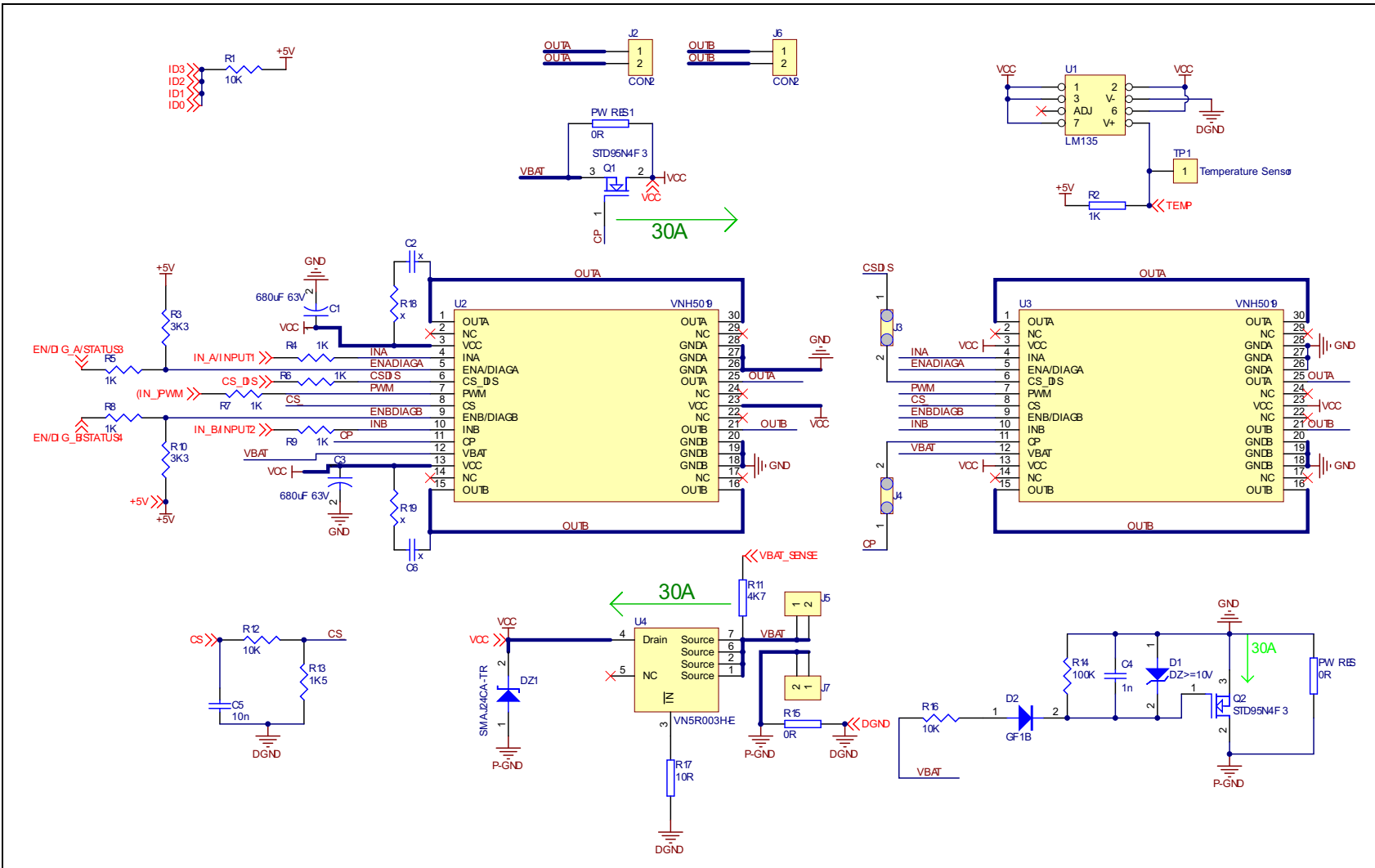

Figure 4. VN5019A daughterboard application schematic (part 2)



1.2 STM8 motherboard

Figure 5. STM8 motherboard top layer

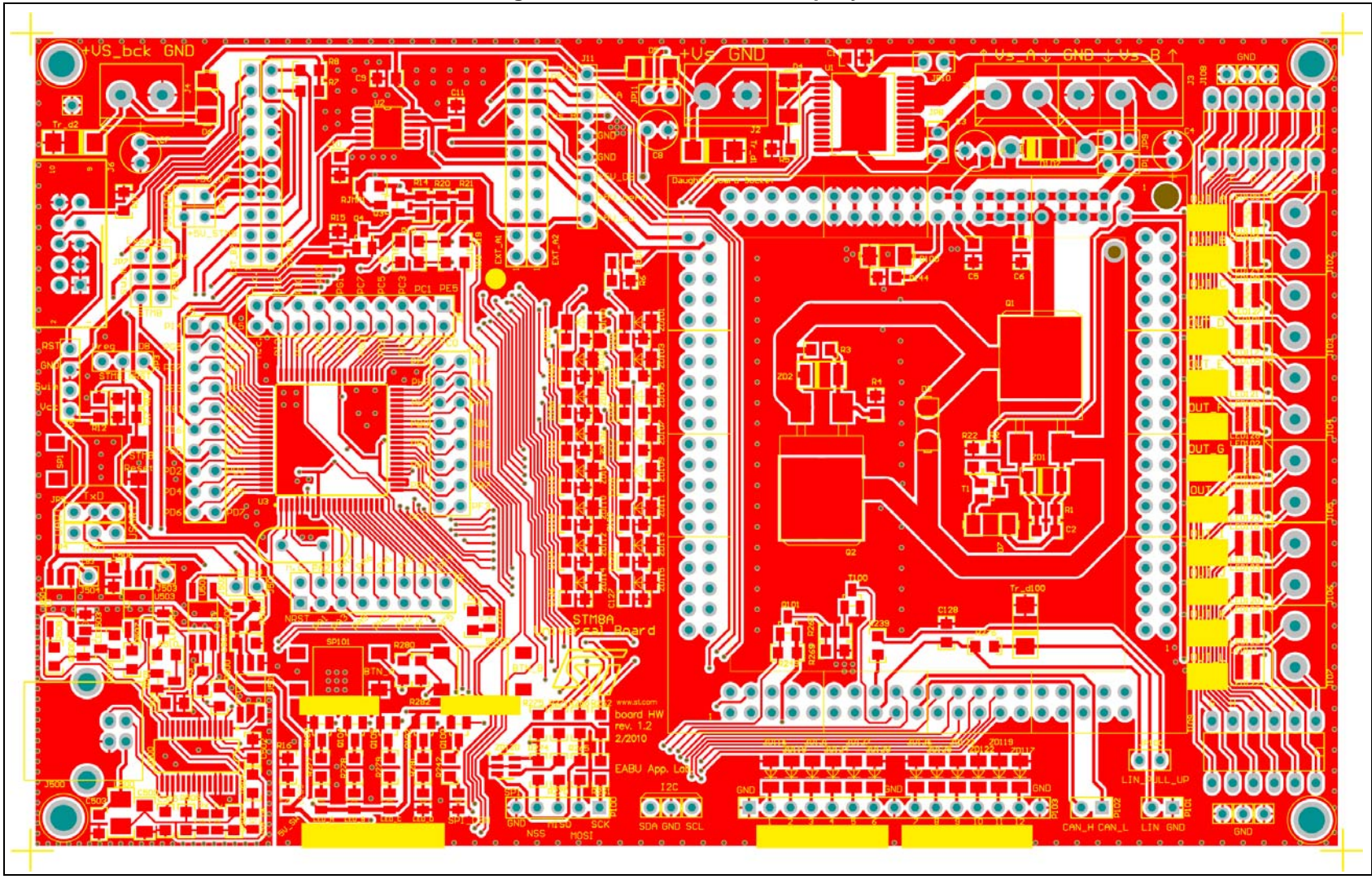

Figure 6. STM8 motherboard bottom layer

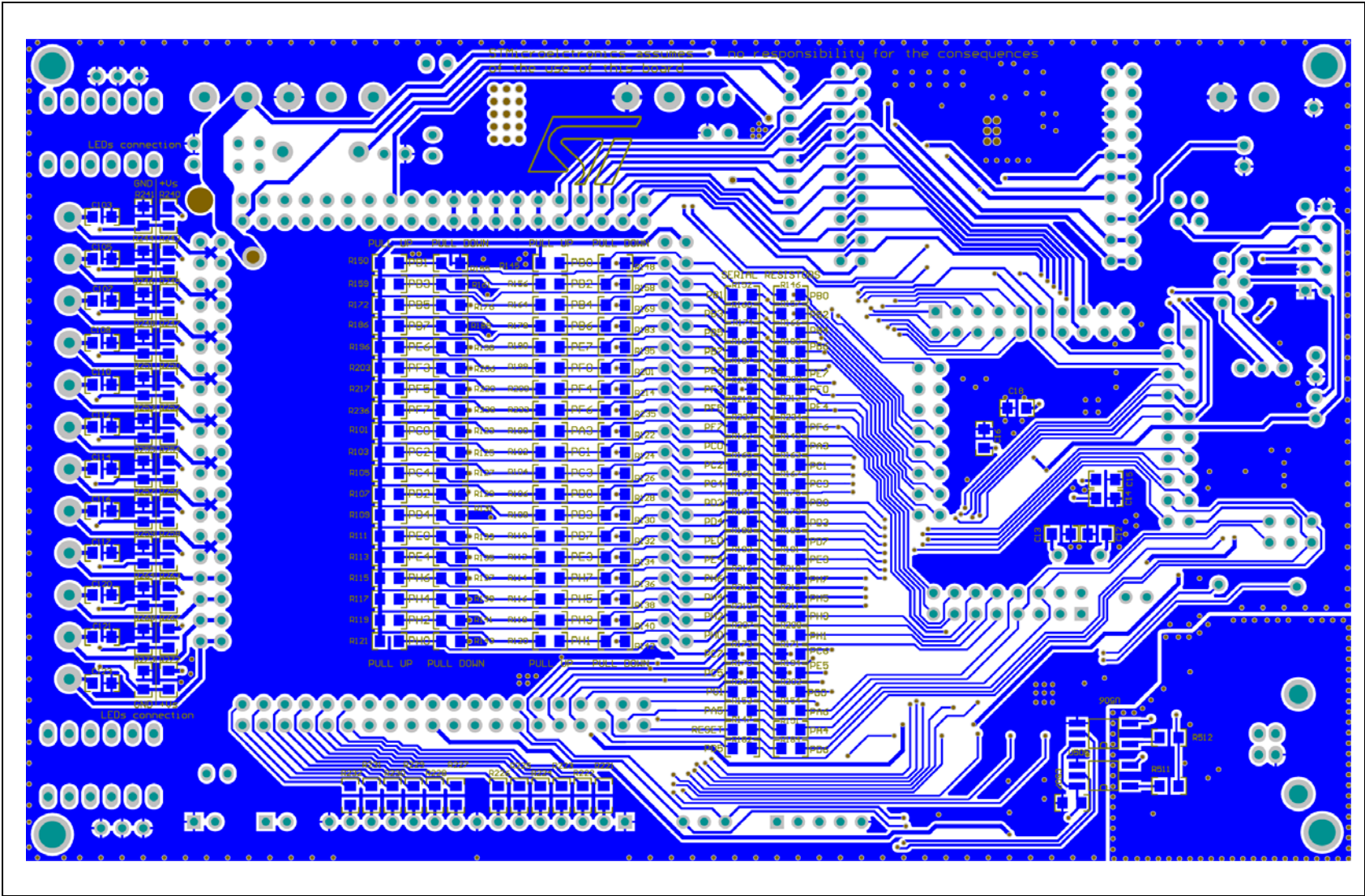

Figure 7. STM8 motherboard - I/O & Body application schematic

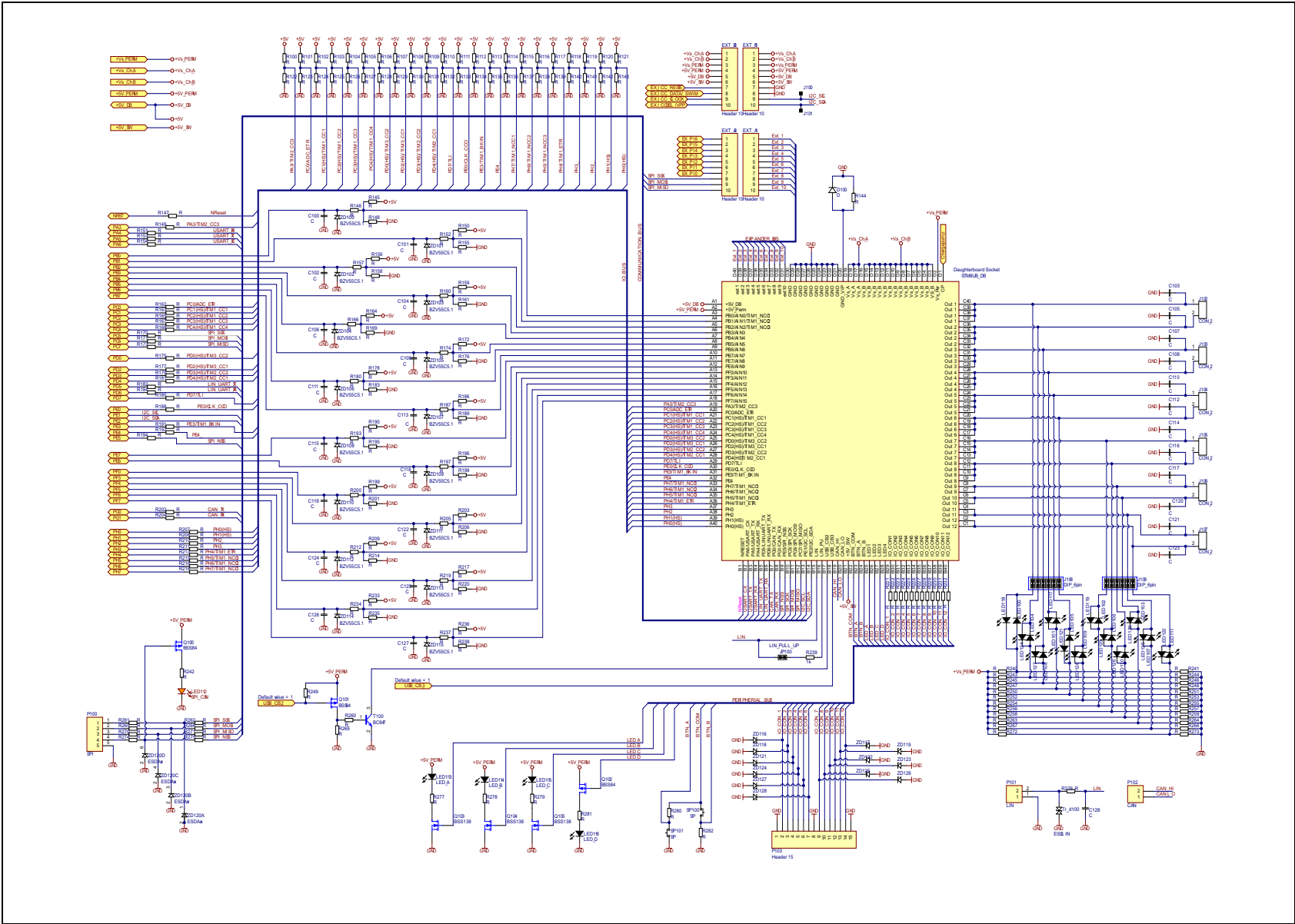

Figure 8. STM8 motherboard - STM8 & Supply application schematic

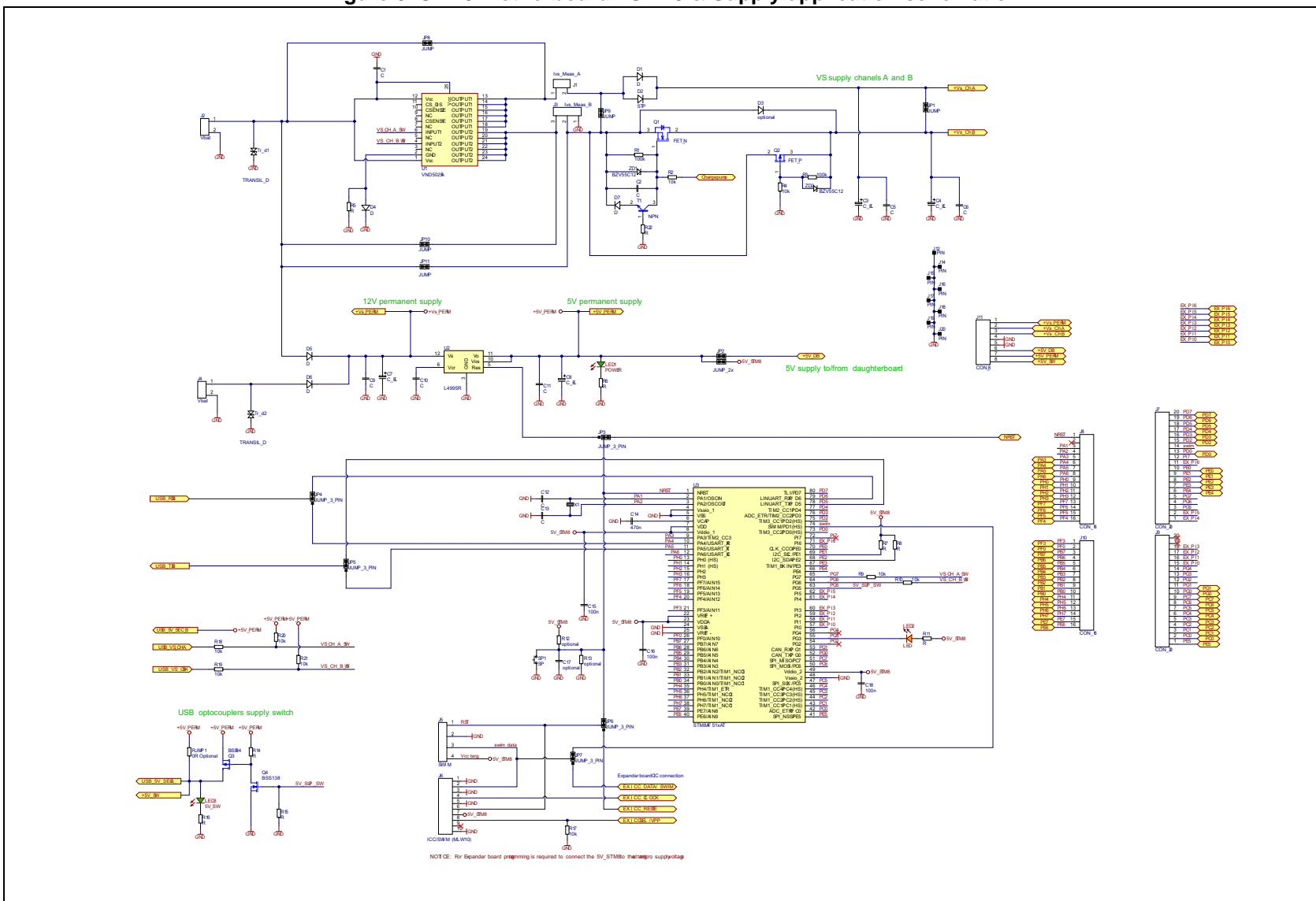
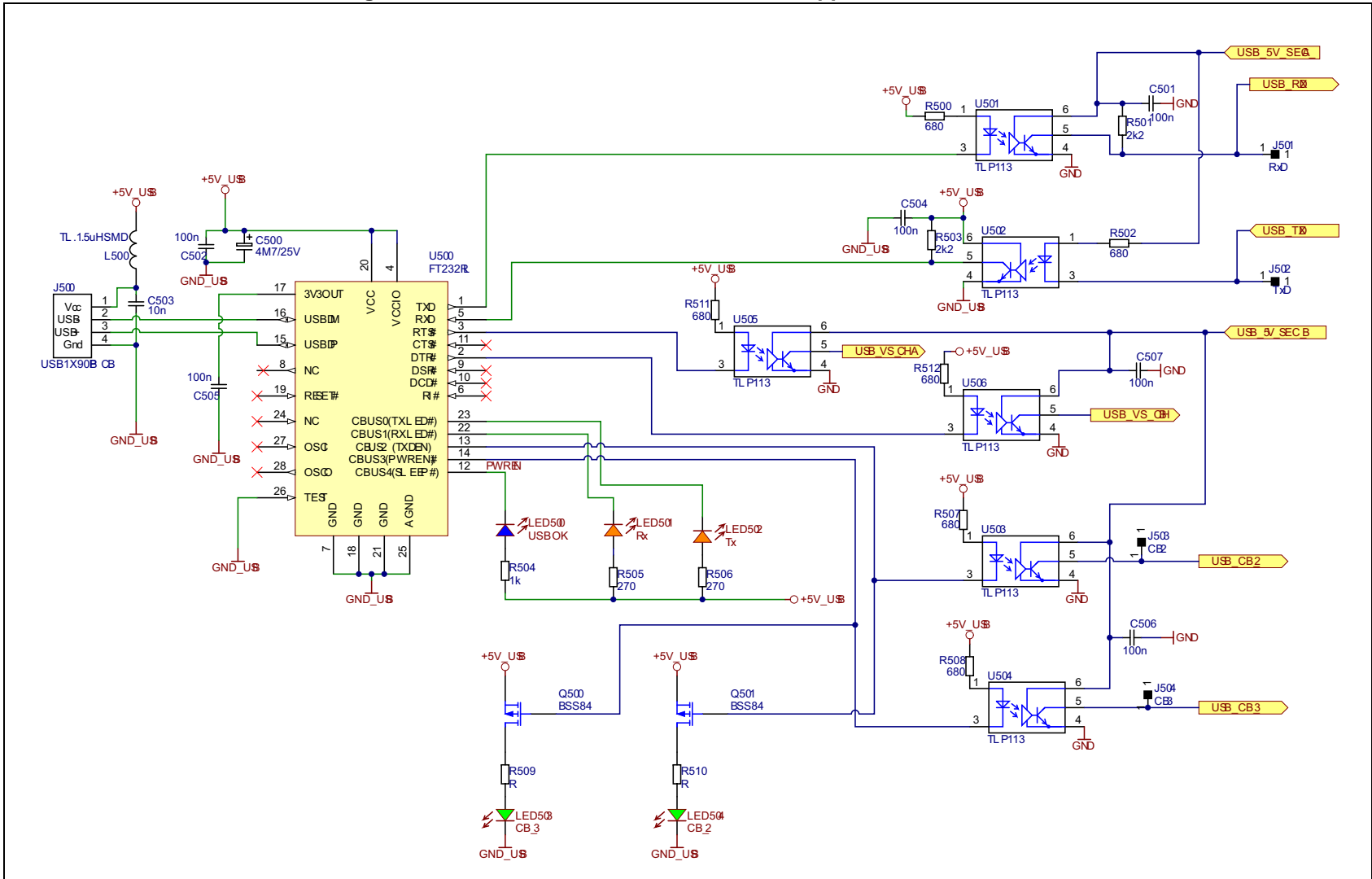



Figure 9. STM8 motherboard - USB Interface application schematic



2 Revision history

Table 2. Document revision history

Date	Revision	Changes
22-Jul-2013	1	Initial release.
06-Sep-2013	2	Updated Section 1.2: STM8 motherboard
16-Sep-2013	3	Updated disclaimer.