

## 15 V/200 mA buck converter based on VIPER122



### Features

- Universal input mains range: 85–265 V<sub>AC</sub>
- Frequency: 50-60 Hz
- Output voltage: 15 V
- Output current: 200 mA
- Very compact size
- Stand-by mains consumption: < 30mW at 230 V<sub>AC</sub>
- Average efficiency: > 77%
- Tight line and load regulation over the entire input and output range
- Meets IEC55022 Class B conducted EMI even with reduced EMI filter, thanks to the frequency jittering feature
- WEEE compliant
- RoHS compliant

### Description

The [STEVAL-VP12201B](#) evaluation board implements a 15 V-3 W buck converter mains designed for general purpose applications, operating from 85 to 265 V<sub>AC</sub>.

It is built around the [VIPER122](#) offline high-voltage converter of the [VIPerPlus](#) family with a 730 V Power MOSFET and PWM current mode control.

The [STEVAL-VP12201B](#) features include its small size and minimal BOM, high efficiency, low standby consumption, and tight line and load regulation over the entire input and output range.

Burst mode operation allows extremely low consumption under no load and reduces the average switching frequency to minimize all frequency related losses.

[VIPER122](#) operates at a fixed frequency of 60 kHz with frequency jittering to meet electromagnetic disturbance standards.

Product summary	
15 V/200 mA buck converter based on VIPER122	<a href="#">STEVAL-VP12201B</a>
High voltage converter	<a href="#">VIPER122</a>

# 1 Schematic diagram

**Figure 1. STEVAL-VP12201B circuit schematic**

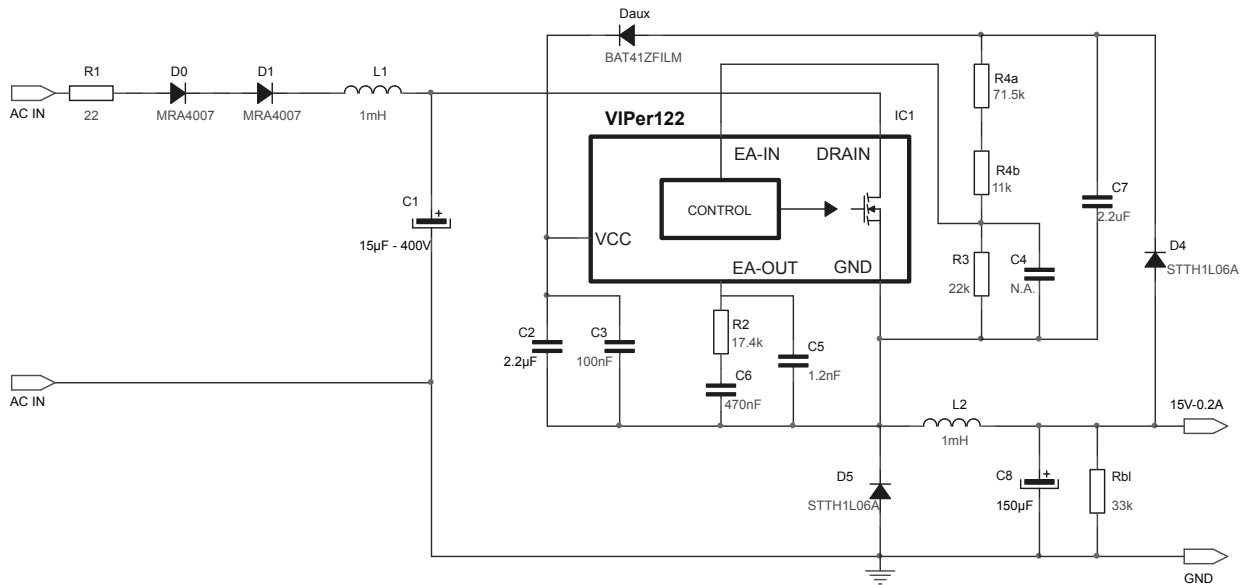

## 2 Line and load regulation, standby consumption and efficiency

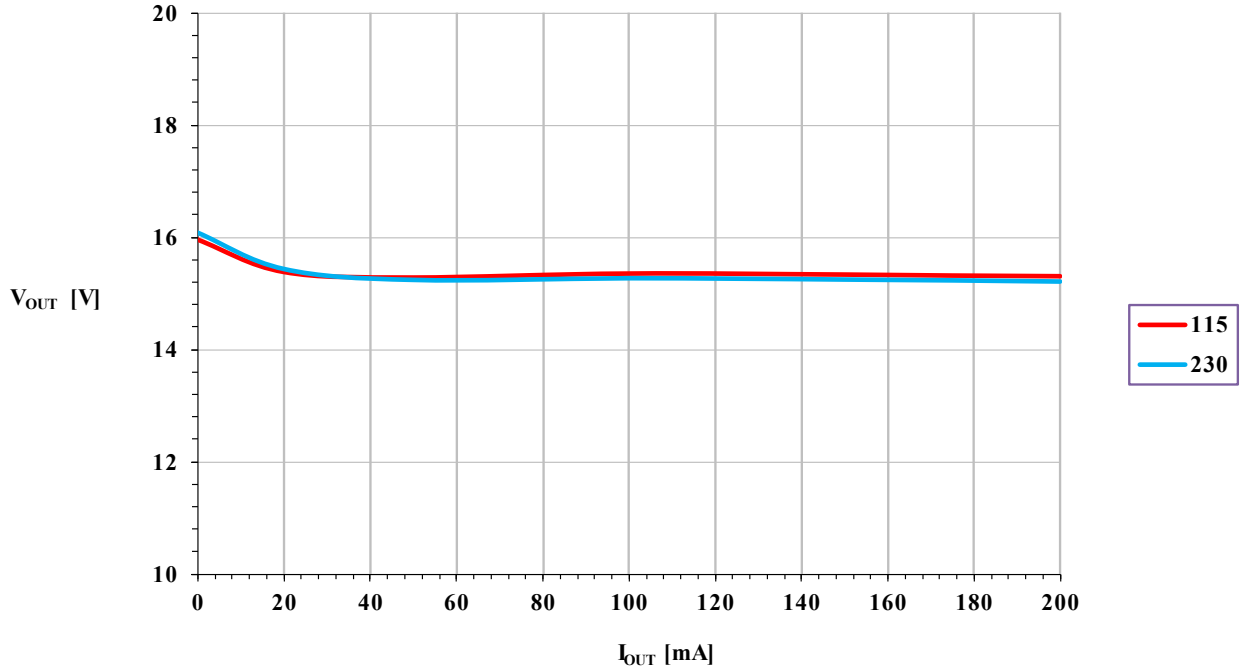
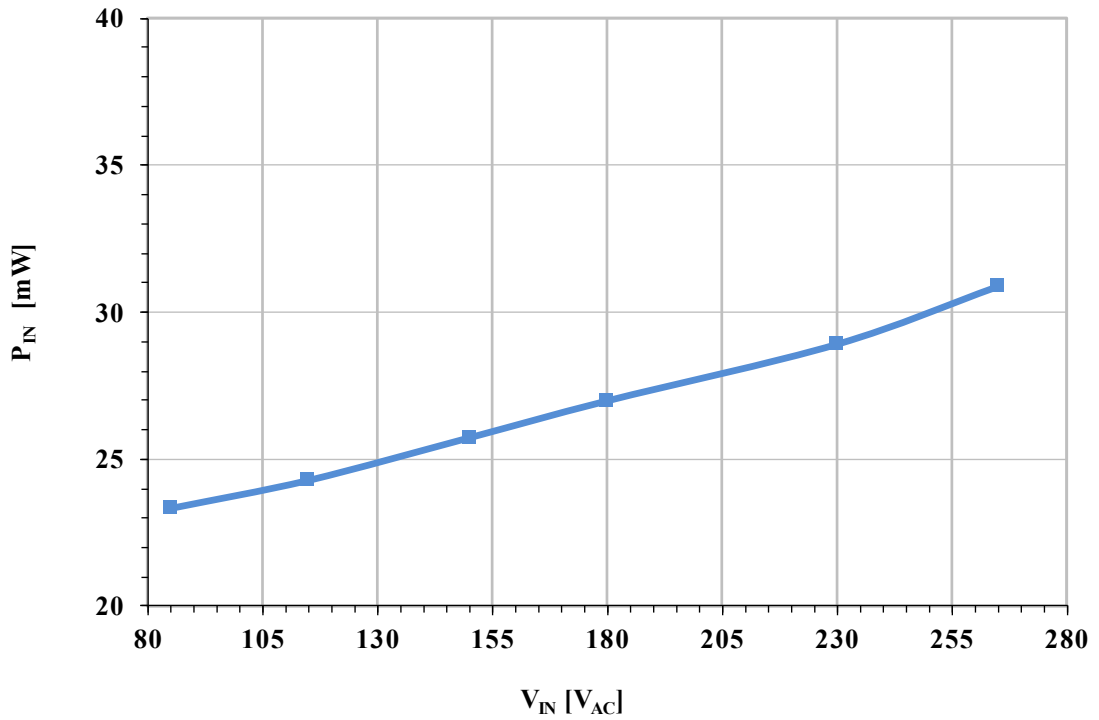
**Figure 2. STEVAL-VP12201B line-load regulation**

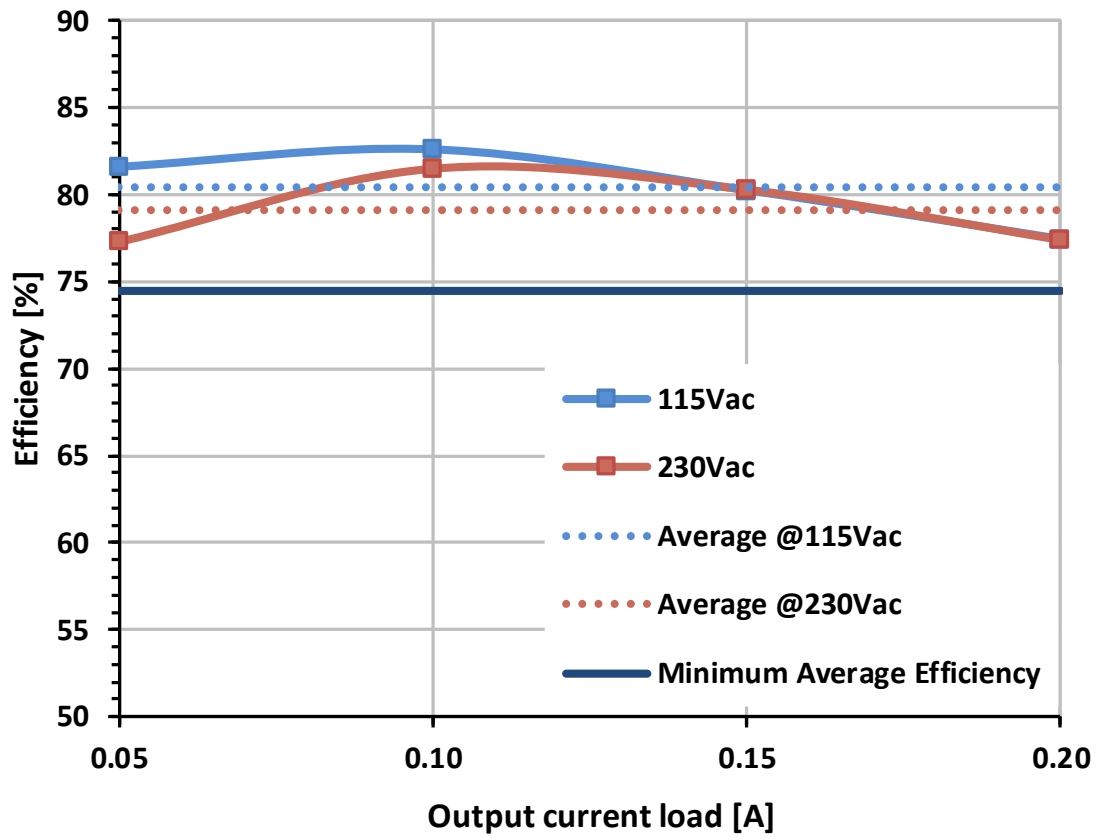
**Figure 3. STEVAL-VP12201B standby consumption**

**Figure 4. STEVAL-VP12201B efficiency**

### 3 Conducted noise measurements

Figure 5. STEVAL-VP12201B CE average measurement at 115 V<sub>AC</sub> full load

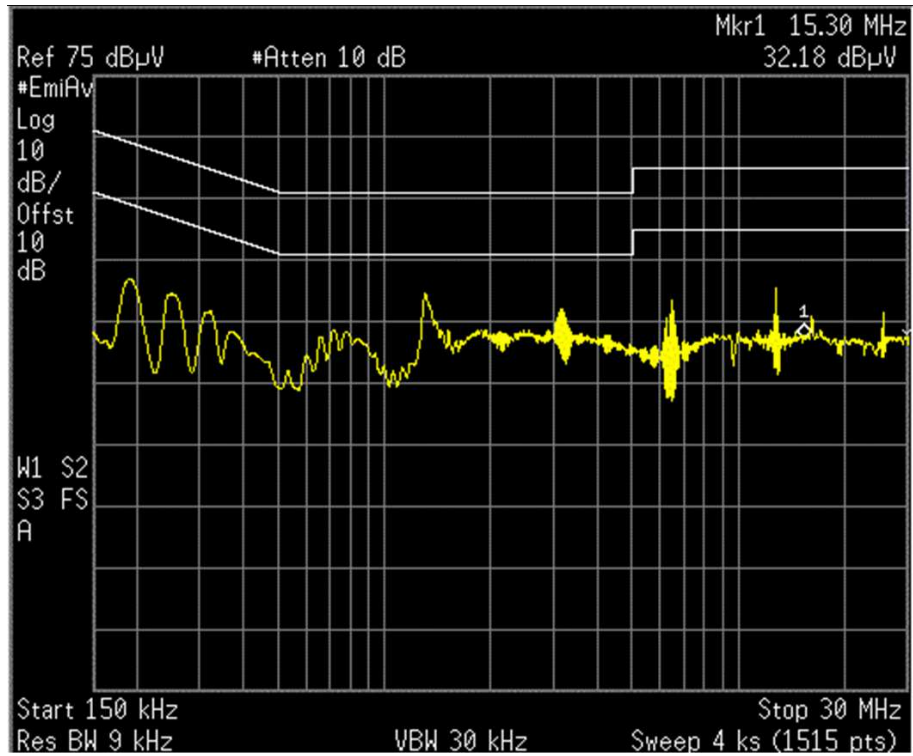
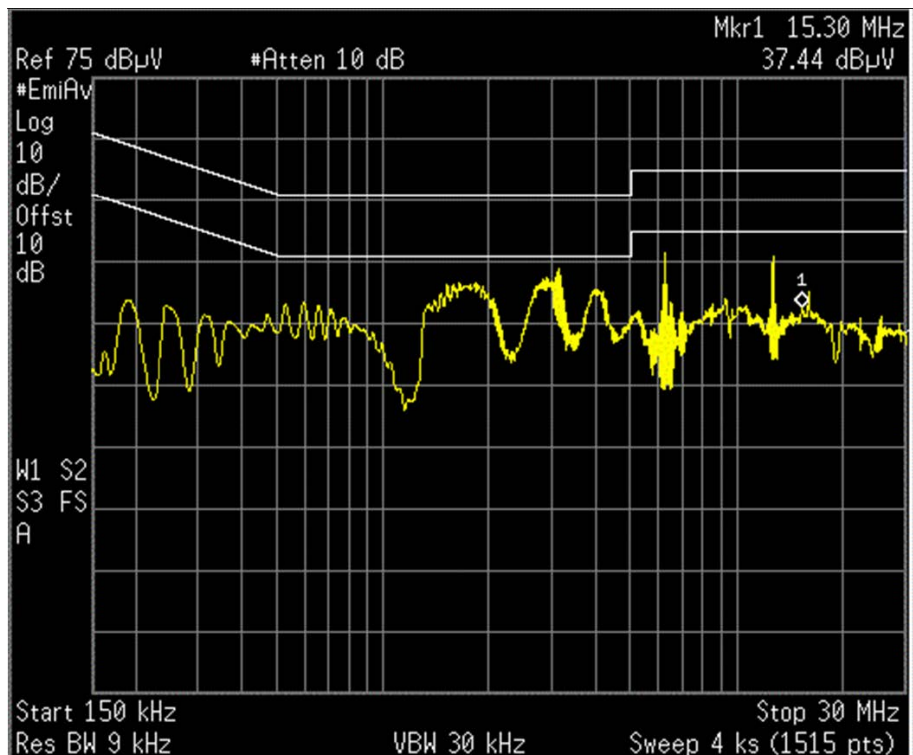

Figure 6. STEVAL-VP12201B CE average measurement at 230 V<sub>AC</sub> full load



## Revision history

**Table 1. Document revision history**

Date	Version	Changes
05-Sep-2019	1	Initial release.