

Automotive-grade 450 V internally clamped IGBT E_{SCIS} 300 mJ

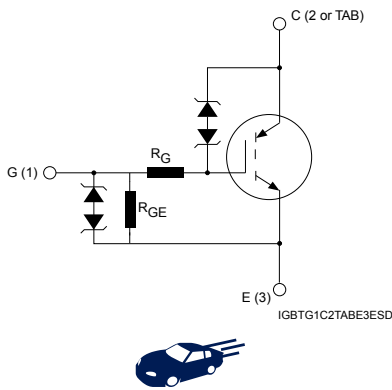
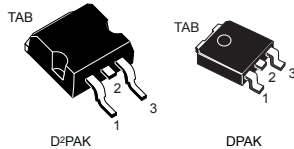

Features

- AEC-Q101 qualified
- SCIS energy of 300 mJ @ $T_J = 25\text{ °C}$
- Parts are 100% tested in SCIS
- ESD gate-emitter protection
- Gate-collector high voltage clamping
- Logic level gate drive
- Very low saturation voltage
- High pulsed current capability
- Gate and gate-emitter resistor

Applications

- Automotive ignition coil driver circuit

Description

This application-specific IGBT utilizes the most advanced PowerMESH™ technology optimized for coil driving in the harsh environment of automotive ignition systems. These devices show very low on-state voltage and very high SCIS energy capability over a wide operating temperature range. Moreover, ESD-protected logic level gate input and an integrated gate resistor means no external protection circuitry is required.

Product status

STGB20N45LZAG

STGD20N45LZAG

Product summary

Order code	STGB20N45LZAG
Marking	GB20N45LZ
Package	D²PAK
Packing	Tape and reel
Order code	STGD20N45LZAG
Marking	GD20N45LZ
Package	DPAK
Packing	Tape and reel

1 Electrical ratings

Table 1. Absolute maximum ratings

Symbol	Parameter	Value	Unit
V_{CES}	Collector-emitter voltage ($V_{GE} = 0\text{ V}$)	$V_{CES(\text{clamped})}$	V
V_{ECS}	Emitter-collector voltage ($V_{GE} = 0\text{ V}$)	20	V
I_C	Continuous collector current at $T_C = 25\text{ °C}$, $V_{GE} = 4\text{ V}$	25	A
	Continuous collector current at $T_C = 100\text{ °C}$, $V_{GE} = 4\text{ V}$	25	A
$I_{CP}^{(1)}$	Pulsed collector current	50	A
V_{GE}	Gate-emitter voltage	$V_{GE(\text{clamped})}$	V
P_{TOT}	Total dissipation at $T_C = 25\text{ °C}$	150	W
$E_{SCIS_25}^{(2)}$	Self-clamping inductive switching energy	300	mJ
$E_{SCIS_150}^{(3)}$	Self-clamping inductive switching energy @ $T_J = 150\text{ °C}$	170	mJ
ESD	Human body model, $R = 1.5\text{ k}\Omega$, $C = 100\text{ pF}$	4	kV
	Charged device model	2	kV
T_{STG}	Storage temperature range	-55 to 175	°C
T_J	Operating junction temperature range		

1. Pulse width limited by maximum junction temperature.
2. Starting $T_J = 25\text{ °C}$, $L = 3\text{ mH}$, $R_g = 1\text{ k}\Omega$, $V_{cc} = 50\text{ V}$ during inductor charging and $V_{cc} = 0\text{ V}$ during the time in clamp. Parts are 100% electrically tested in production.
3. Starting $T_J = 150\text{ °C}$, $L = 3\text{ mH}$, $R_g = 1\text{ k}\Omega$, $V_{cc} = 50\text{ V}$ during inductor charging and $V_{cc} = 0\text{ V}$ during the time in clamp.

Table 2. Thermal data

Symbol	Parameter	Value		Unit
		D ² PAK	DPAK	
$R_{thj\text{-case}}$	Thermal resistance junction-case	1		°C/W
$R_{thj\text{-amb}}$	Thermal resistance junction-ambient	62.5	100	°C/W

2 Electrical characteristics

$T_C = 25\text{ °C}$ unless otherwise specified

Table 3. Static characteristics

Symbol	Parameter	Test conditions	Min.	Typ.	Max.	Unit
$V_{CES(\text{clamped})}$	Collector-emitter clamped voltage	$I_C = 2\text{ mA}, V_{GE} = 0\text{ V}$		450		V
		$I_C = 2\text{ mA}, V_{GE} = 0\text{ V}, T_J = -40\text{ °C to }175\text{ °C}$	415		475	V
$V_{(BR)ECS}$	Emitter-collector break-down voltage	$I_C = 75\text{ mA}, V_{GE} = 0\text{ V}$	20			V
$V_{GE(\text{clamped})}$	Gate-emitter clamped voltage	$I_G = \pm 2\text{ mA}, T_J = -40\text{ °C to }175\text{ °C}$	12		16	V
$V_{CE(\text{sat})}$	Collector-emitter saturation voltage	$V_{GE} = 4\text{ V}, I_C = 6\text{ A}$		1.1	1.25	V
		$V_{GE} = 4.5\text{ V}, I_C = 10\text{ A}, T_J = 175\text{ °C}$		1.25	1.55	V
$V_{GE(\text{th})}$	Gate-threshold voltage	$V_{GE} = V_{CE}, I_C = 1\text{ mA}$	1.3	1.7	2.1	V
		$V_{GE} = V_{CE}, I_C = 1\text{ mA}, T_J = 175\text{ °C}$		1.05		V
I_{CES}	Collector cut-off current	$V_{CE} = 15\text{ V}, V_{GE} = 0\text{ V}, T_J = 150\text{ °C}$			20	μA
		$V_{CE} = 200\text{ V}, V_{GE} = 0\text{ V}, T_J = 150\text{ °C}$			100	μA
I_{GES}	Gate-emitter leakage current	$V_{GE} = \pm 10\text{ V}, V_{CE} = 0\text{ V}$		625		μA
		$V_{GE} = \pm 10\text{ V}, V_{CE} = 0\text{ V}, T_J = -40\text{ °C to }175\text{ °C}$	450		900	μA
R_{GE}	Gate emitter resistance		11	16	22	k Ω
R_G	Gate resistance			120		Ω

Table 4. Dynamic characteristics

Symbol	Parameter	Test conditions	Min.	Typ.	Max.	Unit
C_{ies}	Input capacitance	$V_{CE} = 25\text{ V}, f = 1\text{ MHz}, V_{GE} = 0\text{ V}$	-	1011	-	pF
C_{oes}	Output capacitance		-	87	-	
C_{res}	Reverse transfer capacitance		-	14	-	
Q_g	Total gate charge	$V_{CE} = 13\text{ V}, I_C = 10\text{ A}, V_{GE} = 0\text{ to }5\text{ V}$	-	26	-	nC

Table 5. Resistive load switching characteristics

Symbol	Parameter	Test conditions	Min.	Typ.	Max.	Unit
$t_{d(on)}$	Turn-on delay time	$V_{CC} = 14\text{ V}$, $V_{GE} = 5\text{ V}$,	-	1.1	-	μs
t_r	Current rise time	$R_L = 1\ \Omega$, $R_G = 1\ \text{k}\Omega$ (see Figure 17. Test circuit for resistive load switching)	-	3.6	-	μs
$t_{d(on)}$	Turn-on delay time	$V_{CC} = 14\text{ V}$, $V_{GE} = 5\text{ V}$,	-	1.06	-	μs
t_r	Current rise time	$R_L = 1\ \Omega$, $R_G = 1\ \text{k}\Omega$, $T_J = 150\text{ }^\circ\text{C}$ (see Figure 17. Test circuit for resistive load switching)	-	3.5	-	μs

Table 6. Inductive load switching characteristics

Symbol	Parameter	Test conditions	Min.	Typ.	Max.	Unit
$t_{d(off)}$	Turn-off delay time	$V_{CC} = 300\text{ V}$, $L = 1\ \text{mH}$,	-	4.6	-	μs
t_f	Current fall time	$I_C = 10\text{ A}$, $V_{GE} = 5\text{ V}$, $R_G = 1\ \text{k}\Omega$	-	8.4	-	μs
dV/dt	Turn-off voltage slope	(see Figure 16. Test circuit for inductive load switching)	-	165	-	$\text{V}/\mu\text{s}$
$t_{d(off)}$	Turn-off delay time	$V_{CC} = 300\text{ V}$, $L = 1\ \text{mH}$,	-	4.7	-	μs
t_f	Current fall time	$I_C = 10\text{ A}$, $V_{GE} = 5\text{ V}$, $R_G = 1\ \text{k}\Omega$, $T_J = 150\text{ }^\circ\text{C}$	-	9.8	-	μs
dV/dt	Turn-off voltage slope	(see Figure 16. Test circuit for inductive load switching)	-	116	-	$\text{V}/\mu\text{s}$

2.1 Electrical characteristics (curves)

Figure 1. $V_{CE(sat)}$ vs junction temperature ($I_C = 6\text{ A}$)

Figure 2. $V_{CE(sat)}$ vs junction temperature ($I_C = 10\text{ A}$)

Figure 3. Self-clamped inductive switching current

Figure 4. Output characteristics ($T_J = 25\text{ }^\circ\text{C}$)

Figure 5. Output characteristics ($T_J = -40\text{ }^\circ\text{C}$)

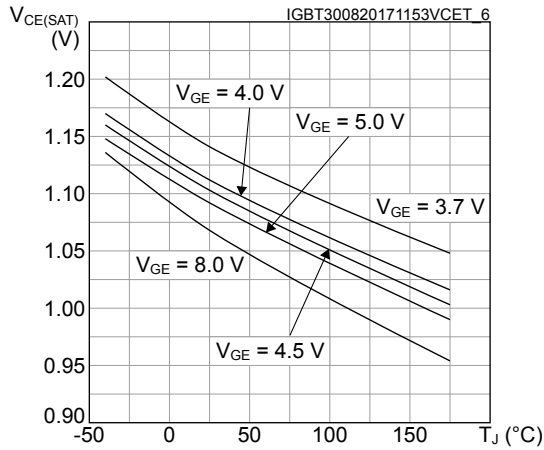
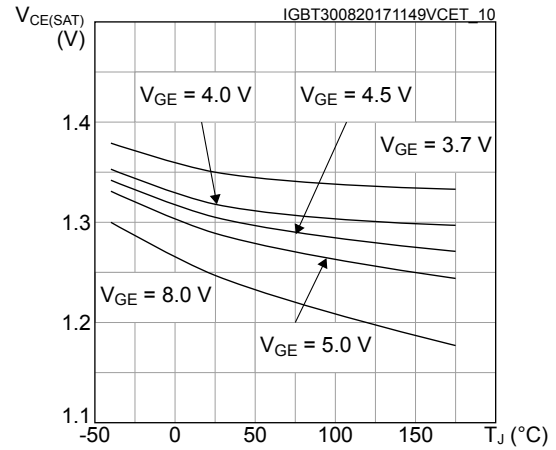
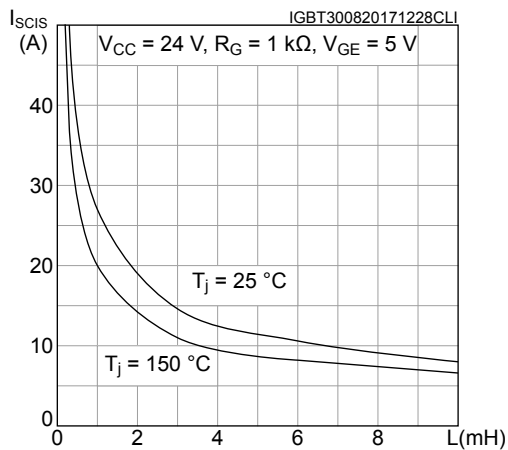
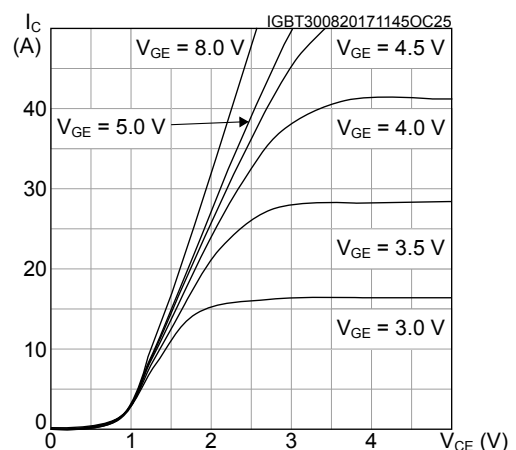
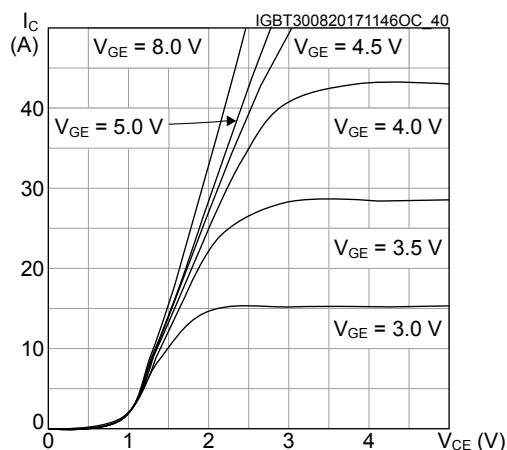
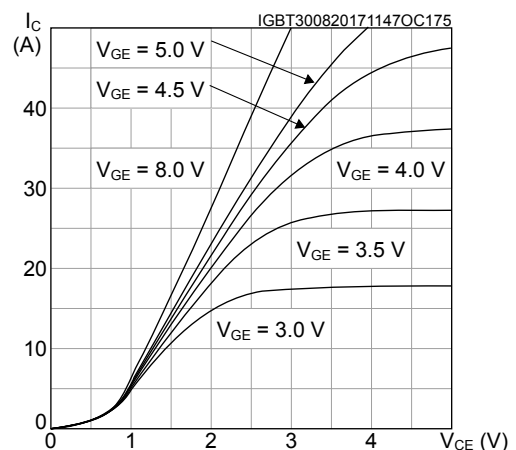
Figure 6. Output characteristics ($T_J = 175\text{ }^\circ\text{C}$)

Figure 7. Transfer characteristics

Figure 8. Collector current vs case temperature

Figure 9. Leakage current vs temperature

Figure 10. Normalized $V_{CES}(\text{clamped})$ vs temperature

Figure 11. Normalized $V_{GE(th)}$ vs temperature

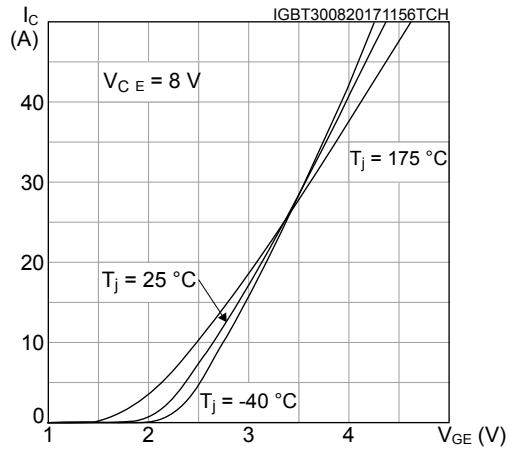
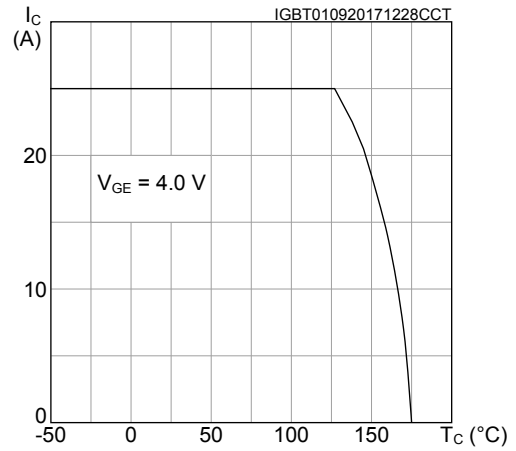
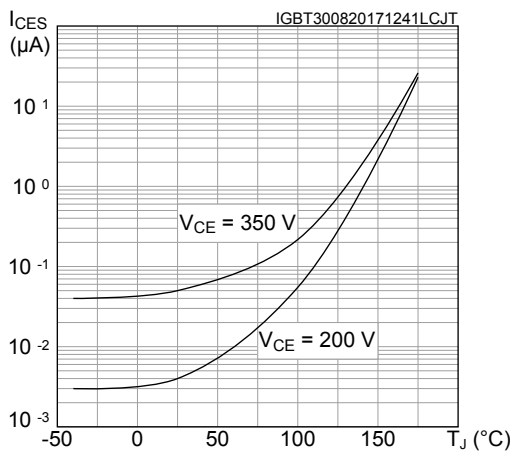
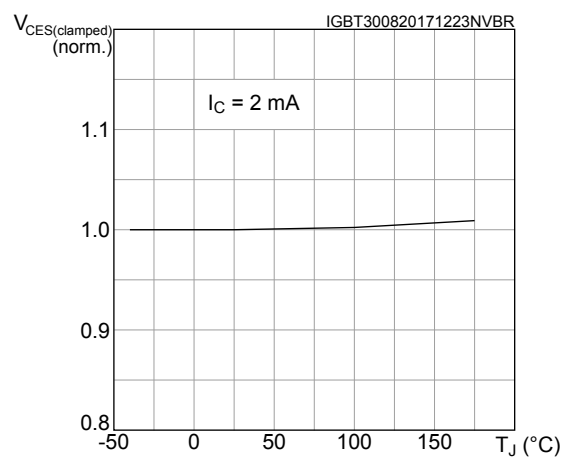
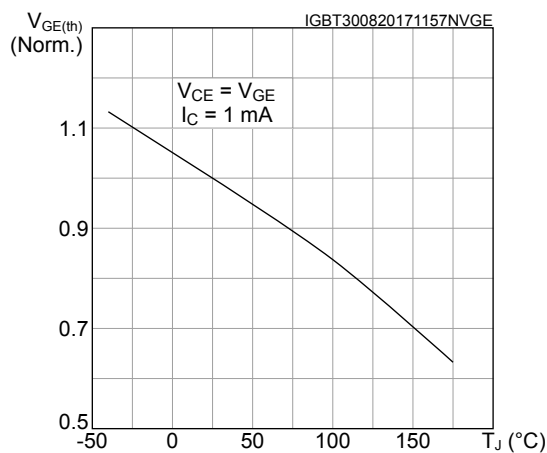
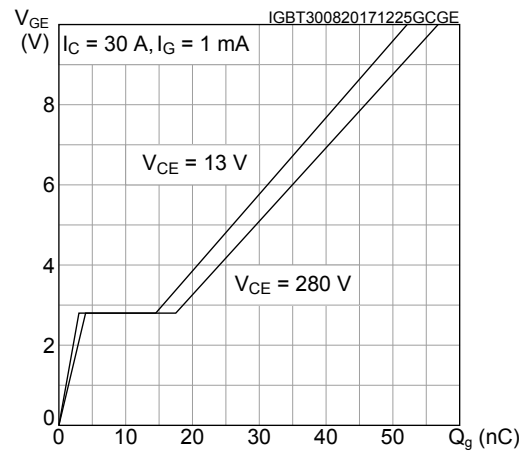
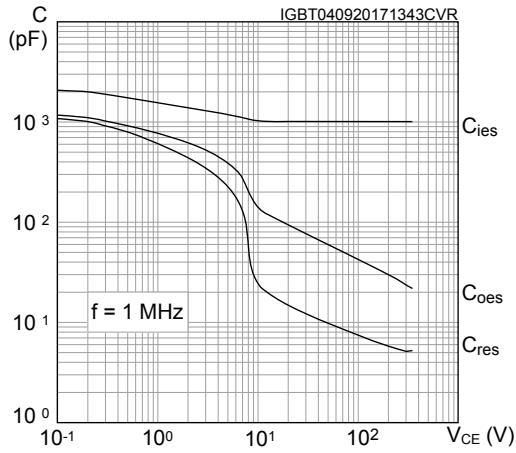
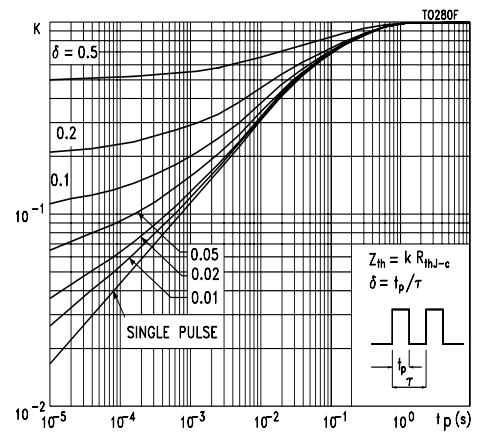
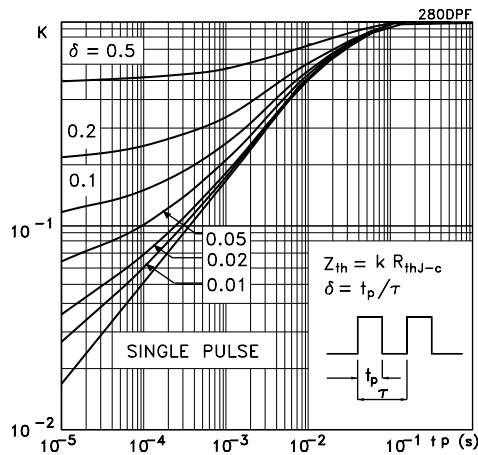
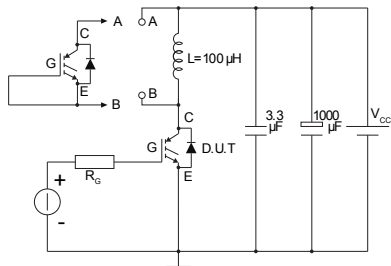
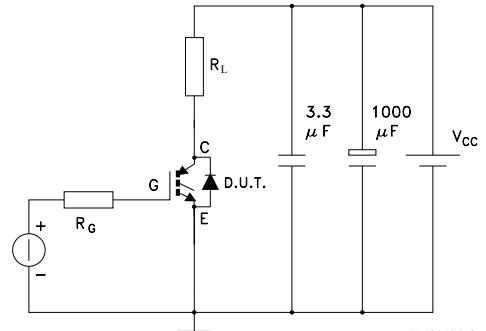
Figure 12. Gate charge vs gate-emitter voltage

Figure 13. Capacitance variations

Figure 14. Thermal impedance for D²PAK

Figure 15. Thermal impedance for DPAK

3 Test circuits

Figure 16. Test circuit for inductive load switching

AM01504v1

Figure 17. Test circuit for resistive load switching

AM01504v2

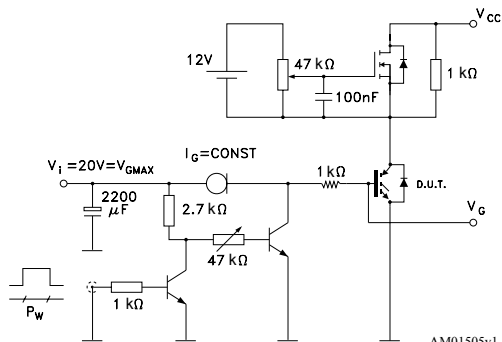
Figure 18. Gate charge test circuit

AM01505v1

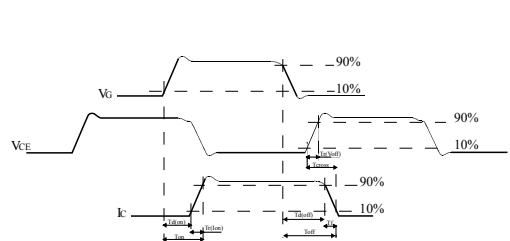
Figure 19. Switching waveform

AM01506v1

4 Package information

In order to meet environmental requirements, ST offers these devices in different grades of ECOPACK® packages, depending on their level of environmental compliance. ECOPACK® specifications, grade definitions and product status are available at: www.st.com. ECOPACK® is an ST trademark.

4.1 D²PAK (TO-263) type A package information

Figure 20. D²PAK (TO-263) type A package outline

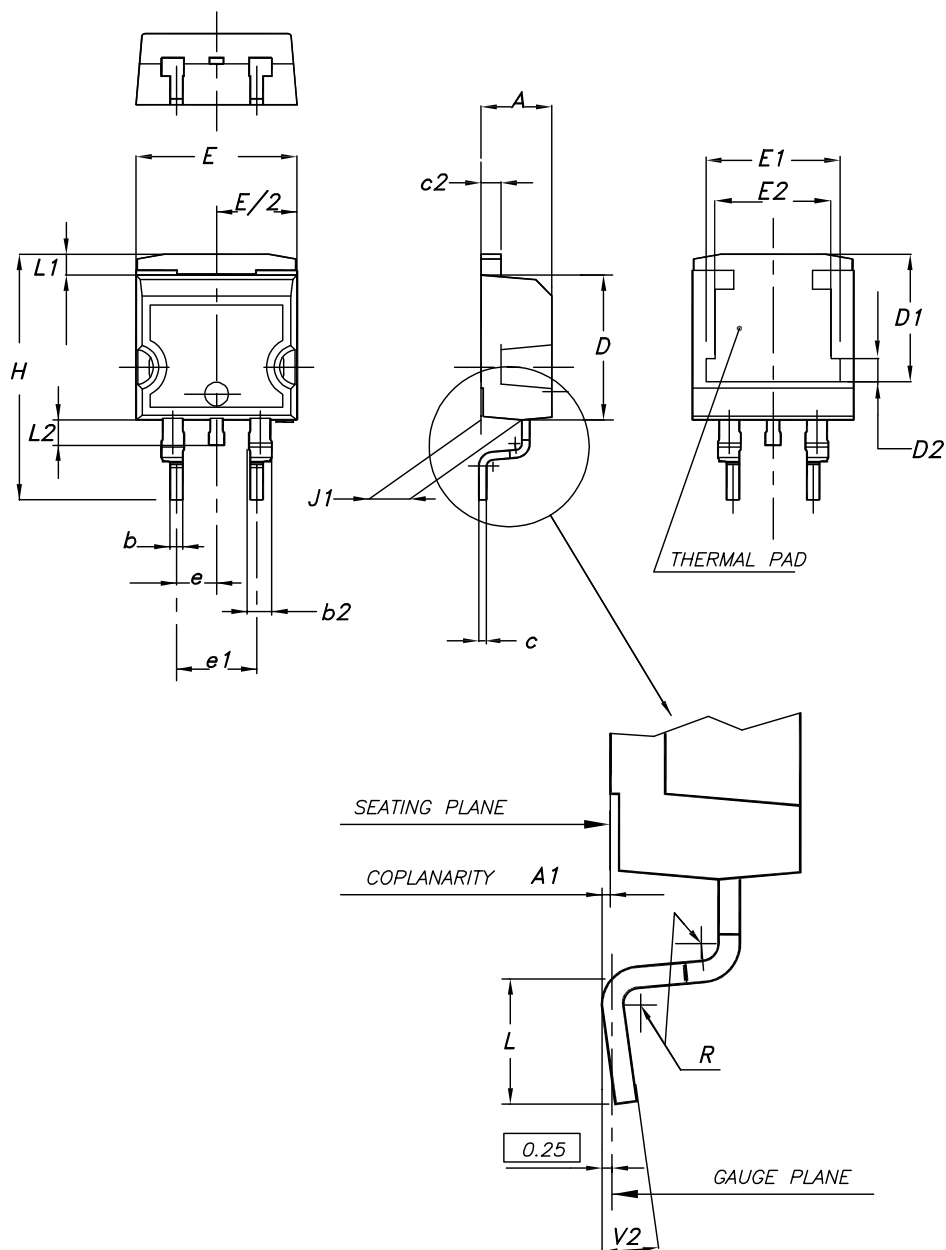

0079457_24

Table 7. D²PAK (TO-263) type A package mechanical data

Dim.	mm		
	Min.	Typ.	Max.
A	4.40		4.60
A1	0.03		0.23
b	0.70		0.93
b2	1.14		1.70
c	0.45		0.60
c2	1.23		1.36
D	8.95		9.35
D1	7.50	7.75	8.00
D2	1.10	1.30	1.50
E	10.00		10.40
E1	8.50	8.70	8.90
E2	6.85	7.05	7.25
e		2.54	
e1	4.88		5.28
H	15.00		15.85
J1	2.49		2.69
L	2.29		2.79
L1	1.27		1.40
L2	1.30		1.75
R		0.40	
V2	0°		8°

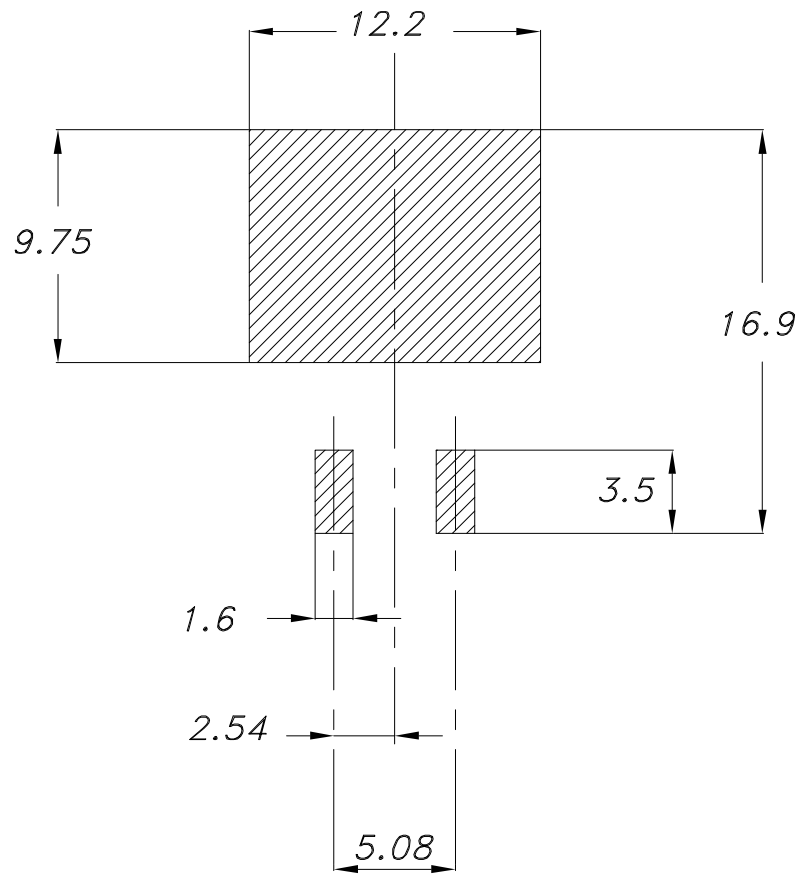
Figure 21. D²PAK (TO-263) recommended footprint (dimensions are in mm)

Footprint

4.2 DPAK (TO-252) type A2 package information

Figure 22. DPAK (TO-252) type A2 package outline



0068772_type-A2_rev24

Table 8. DPAK (TO-252) type A2 mechanical data

Dim.	mm		
	Min.	Typ.	Max.
A	2.20		2.40
A1	0.90		1.10
A2	0.03		0.23
b	0.64		0.90
b4	5.20		5.40
c	0.45		0.60
c2	0.48		0.60
D	6.00		6.20
D1	4.95	5.10	5.25
E	6.40		6.60
E1	5.10	5.20	5.30
e	2.16	2.28	2.40
e1	4.40		4.60
H	9.35		10.10
L	1.00		1.50
L1	2.60	2.80	3.00
L2	0.65	0.80	0.95
L4	0.60		1.00
R		0.20	
V2	0°		8°

Figure 23. DPAK (TO-252) recommended footprint (dimensions are in mm)



FP_0068772_24

4.3 D²PAK and DPAK packing information

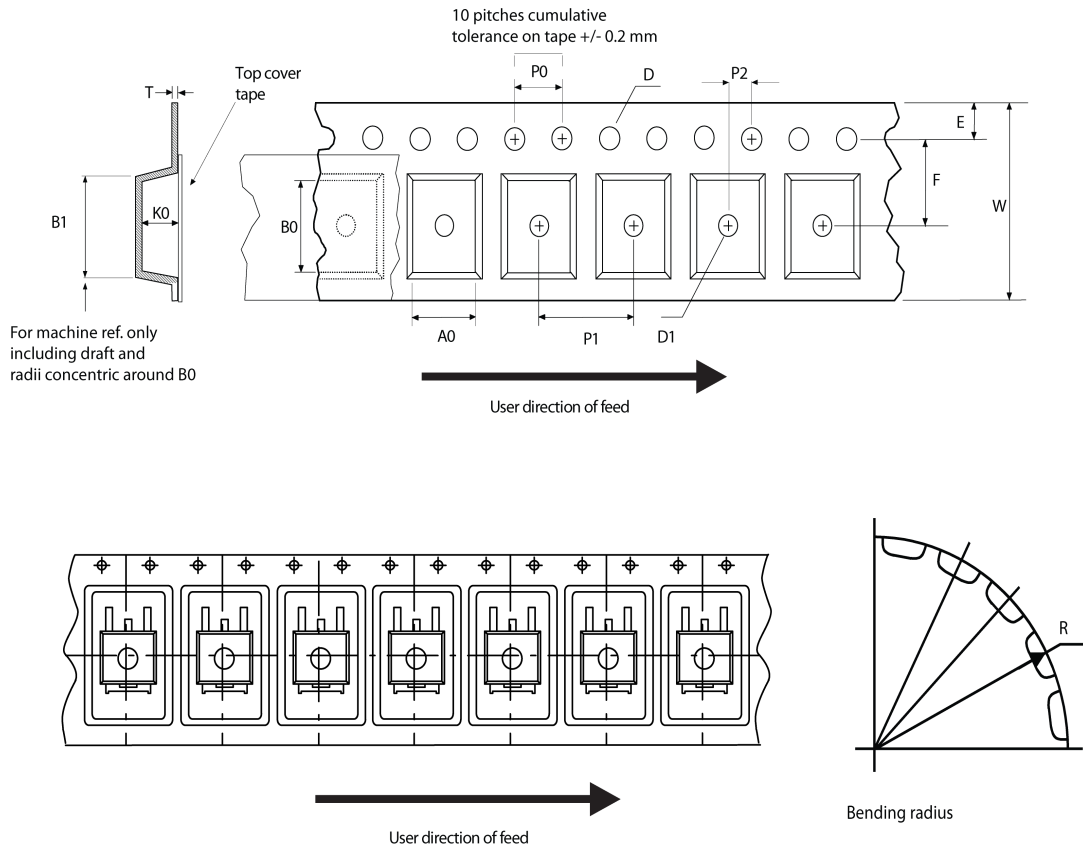
Figure 24. Tape outline

AM08852v1

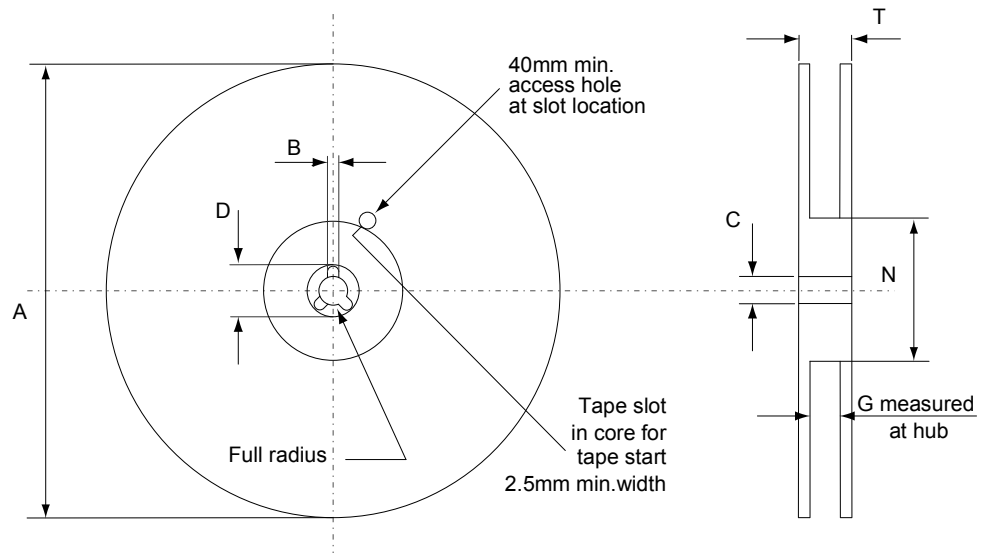
Figure 25. Reel outline

AM06038v1

Table 9. D²PAK tape and reel mechanical data

Tape			Reel			
Dim.	mm		Dim.	mm		
	Min.	Max.		Min.	Max.	
A0	10.5	10.7	A		330	
B0	15.7	15.9	B	1.5		
D	1.5	1.6	C	12.8	13.2	
D1	1.59	1.61	D	20.2		
E	1.65	1.85	G	24.4	26.4	
F	11.4	11.6	N	100		
K0	4.8	5.0	T		30.4	
P0	3.9	4.1	Base quantity Bulk quantity			
P1	11.9	12.1				1000
P2	1.9	2.1				1000
R	50					
T	0.25	0.35				
W	23.7	24.3				

Table 10. DPAK tape and reel mechanical data

Tape			Reel		
Dim.	mm		Dim.	mm	
	Min.	Max.		Min.	Max.
A0	6.8	7	A		330
B0	10.4	10.6	B	1.5	
B1		12.1	C	12.8	13.2
D	1.5	1.6	D	20.2	
D1	1.5		G	16.4	18.4
E	1.65	1.85	N	50	
F	7.4	7.6	T		22.4
K0	2.55	2.75			
P0	3.9	4.1	Base qty.		2500
P1	7.9	8.1	Bulk qty.		2500
P2	1.9	2.1			
R	40				
T	0.25	0.35			
W	15.7	16.3			

Revision history

Table 11. Document revision history

Date	Revision	Changes
30-Oct-2015	1	First release.
01-Sep-2017	2	Modified <i>Table 2: "Absolute maximum ratings"</i> , <i>Table 3: "Thermal data"</i> , <i>Table 4: "Static characteristics"</i> and <i>Table 5: "Dynamic characteristics"</i> . Added <i>Section 2.1: "Electrical characteristics (curves)"</i> . Modified <i>Section 4: "Package information"</i> . Minor text changes.
06-Sep-2017	3	Modified <i>Figure 2: "$V_{CE(sat)}$ vs. junction temperature ($I_C = 6.0\text{ A}$)"</i> , <i>Figure 4: "Self clamped inductive switching current vs. inductance"</i> and <i>Figure 11: "Normalized $V_{CES(clamped)}$ vs. junction temperature"</i> . Minor text changes.
11-Sep-2017	4	Modified <i>Section 4.1: "D²PAK (TO-263) type A package information"</i> . Minor text changes.
02-Nov-2017	5	Updated <i>Table 4: "Static characteristics"</i> . Minor text changes
21-Feb-2018	6	Removed maturity status indication from cover page. The document status is production data. Updated Section 1 Electrical ratings , Table 2. Thermal data and Table 3. Static characteristics . Minor text changes

Contents

1	Electrical ratings	2
2	Electrical characteristics	3
2.1	Electrical characteristics (curves)	5
3	Test circuits	8
4	Package information	9
4.1	D ² PAK (TO-263) type A package information	9
4.2	DPAK (TO-252) type A2 package information	11
4.3	D ² PAK and DPAK packing information	14
	Revision history	18
	Contents	19
	Disclaimer	20