

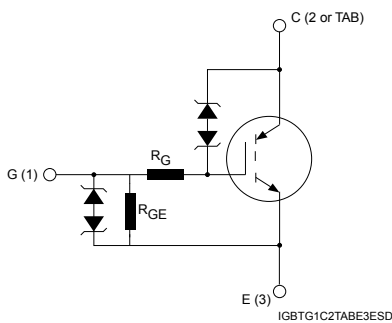

## Automotive-grade 360 V internally clamped IGBT E<sub>SCIS</sub> 300 mJ

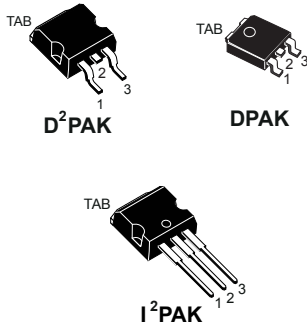

### Features

- AEC-Q101 qualified 
- SCIS energy of 300 mJ @ T<sub>J</sub> = 25 °C
- Parts are 100% tested in SCIS
- ESD gate-emitter protection
- Gate-collector high voltage clamping
- Logic level gate drive
- Very low saturation voltage
- High pulsed current capability
- Gate and gate-emitter resistor

### Applications

- Automotive ignition coil driver circuit

### Description

This application-specific IGBT utilizes the most advanced PowerMESH technology optimized for coil driving in the harsh environment of automotive ignition systems. These devices show very low on-state voltage and very high SCIS energy capability over a wide operating temperature range. Moreover, ESD-protected logic level gate input and an integrated gate resistor means no external protection circuitry is required.

#### Product status link

[STGB25N36LZAG](#)

[STGD25N36LZAG](#)

[STGI25N36LZAG](#)

# 1 Electrical ratings

**Table 1. Absolute maximum ratings**

Symbol	Parameter	Value	Unit
$V_{CES}$	Collector-emitter voltage ( $V_{GE} = 0\text{ V}$ )	$V_{CES(\text{clamped})}$	V
$V_{ECS}$	Emitter-collector voltage ( $V_{GE} = 0\text{ V}$ )	20	V
$I_C$	Continuous collector current at $T_C = 25\text{ °C}$ , $V_{GE} = 4\text{ V}$	25	A
	Continuous collector current at $T_C = 100\text{ °C}$ , $V_{GE} = 4\text{ V}$	25	A
$I_{CP}^{(1)}$	Pulsed collector current	50	A
$V_{GE}$	Gate-emitter voltage	$V_{GE(\text{clamped})}$	V
$P_{TOT}$	Total power dissipation at $T_C = 25\text{ °C}$	150	W
$E_{SCIS\_25}^{(2)}$	Self-clamping inductive switching energy	300	mJ
$E_{SCIS\_150}^{(3)}$	Self-clamping inductive switching energy @ $T_J = 150\text{ °C}$	170	mJ
ESD	Human body model, $R = 1.5\text{ k}\Omega$ , $C = 100\text{ pF}$	4	kV
	Charged device model	2	kV
$T_{STG}$	Storage temperature range	-55 to 175	°C
$T_J$	Operating junction temperature range		°C

1. Pulse width limited by maximum junction temperature.
2. Starting  $T_J = 25\text{ °C}$ ,  $L = 3\text{ mH}$ ,  $R_g = 1\text{ k}\Omega$ ,  $V_{cc} = 50\text{ V}$  during inductor charging and  $V_{cc} = 0\text{ V}$  during the time in clamp. Parts are 100% electrically tested in production.
3. Starting  $T_J = 150\text{ °C}$ ,  $L = 3\text{ mH}$ ,  $R_g = 1\text{ k}\Omega$ ,  $V_{cc} = 50\text{ V}$  during inductor charging and  $V_{cc} = 0\text{ V}$  during the time in clamp.

**Table 2. Thermal data**

Symbol	Parameter	Value			Unit
		D <sup>2</sup> PAK	DPAK	I <sup>2</sup> PAK	
$R_{thj\text{-case}}$	Thermal resistance junction-case	1			°C/W
$R_{thj\text{-amb}}$	Thermal resistance junction-ambient	62.5	100	62.5	°C/W

## 2 Electrical characteristics

$T_C = 25\text{ }^\circ\text{C}$  unless otherwise specified

**Table 3. Static characteristics**

Symbol	Parameter	Test conditions	Min.	Typ.	Max.	Unit
$V_{CES(\text{clamped})}$	Collector-emitter clamped voltage	$I_C = 2\text{ mA}, V_{GE} = 0\text{ V}$		350		V
		$I_C = 2\text{ mA}, V_{GE} = 0\text{ V}, T_J = -40\text{ }^\circ\text{C to } 175\text{ }^\circ\text{C}$	325		385	V
$V_{(BR)ECS}$	Emitter-collector break-down voltage	$I_C = 75\text{ mA}, V_{GE} = 0\text{ V}$	20			V
$V_{GE(\text{clamped})}$	Gate-emitter clamped voltage	$I_G = \pm 2\text{ mA}, T_J = -40\text{ }^\circ\text{C to } 175\text{ }^\circ\text{C}$	12		16	V
$V_{CE(\text{sat})}$	Collector-emitter saturation voltage	$V_{GE} = 4\text{ V}, I_C = 6\text{ A}$		1.1	1.25	V
		$V_{GE} = 4.5\text{ V}, I_C = 10\text{ A}, T_J = 175\text{ }^\circ\text{C}$		1.25	1.55	V
$V_{GE(\text{th})}$	Gate-threshold voltage	$V_{GE} = V_{CE}, I_C = 1\text{ mA}$	1.3	1.7	2.1	V
		$V_{GE} = V_{CE}, I_C = 1\text{ mA}, T_J = 175\text{ }^\circ\text{C}$		1.05		V
$I_{CES}$	Collector cut-off current	$V_{CE} = 15\text{ V}, V_{GE} = 0\text{ V}, T_J = 150\text{ }^\circ\text{C}$			20	$\mu\text{A}$
		$V_{CE} = 200\text{ V}, V_{GE} = 0\text{ V}, T_J = 150\text{ }^\circ\text{C}$			100	$\mu\text{A}$
$I_{GES}$	Gate-emitter leakage current	$V_{GE} = \pm 10\text{ V}, V_{CE} = 0\text{ V}$		625		$\mu\text{A}$
		$V_{GE} = \pm 10\text{ V}, V_{CE} = 0\text{ V}, T_J = -40\text{ }^\circ\text{C to } 175\text{ }^\circ\text{C}$	450		900	$\mu\text{A}$
$R_{GE}$	Gate emitter resistance		11	16	22	k $\Omega$
$R_G$	Gate resistance			120		$\Omega$

**Table 4. Dynamic characteristics**

Symbol	Parameter	Test conditions	Min.	Typ.	Max.	Unit
$C_{ies}$	Input capacitance	$V_{CE} = 25\text{ V}, f = 1\text{ MHz}, V_{GE} = 0\text{ V}$	-	1004	-	pF
$C_{oes}$	Output capacitance		-	86.6	-	
$C_{res}$	Reverse transfer capacitance		-	14	-	
$Q_g$	Total gate charge	$V_{CE} = 13\text{ V}, I_C = 10\text{ A}, V_{GE} = 0\text{ to } 5\text{ V}$	-	25.7	-	nC

**Table 5. Resistive load switching characteristics**

Symbol	Parameter	Test conditions	Min.	Typ.	Max.	Unit
$t_{d(on)}$	Turn-on delay time	$V_{CC} = 14\text{ V}$ , $V_{GE} = 5\text{ V}$ ,	-	1.1	-	$\mu\text{s}$
$t_r$	Current rise time	$R_L = 1\ \Omega$ , $R_G = 1\ \text{k}\Omega$ (see Figure 17. Test circuit for resistive load switching)	-	3.6	-	$\mu\text{s}$
$t_{d(on)}$	Turn-on delay time	$V_{CC} = 14\text{ V}$ , $V_{GE} = 5\text{ V}$ ,	-	1.06	-	$\mu\text{s}$
$t_r$	Current rise time	$R_L = 1\ \Omega$ , $R_G = 1\ \text{k}\Omega$ , $T_J = 150\text{ }^\circ\text{C}$ (see Figure 17. Test circuit for resistive load switching)	-	3.5	-	$\mu\text{s}$

**Table 6. Inductive load switching characteristics**

Symbol	Parameter	Test conditions	Min.	Typ.	Max.	Unit
$t_{d(off)}$	Turn-off delay time	$V_{CC} = 300\text{ V}$ , $L = 1\ \text{mH}$ ,	-	7.4	-	ns
$t_f$	Current fall time	$I_C = 10\text{ A}$ , $V_{GE} = 5\text{ V}$ , $R_G = 1\ \text{k}\Omega$	-	5.1	-	ns
dV/dt	Turn-off voltage slope	(see Figure 16. Test circuit for inductive load switching)	-	160.3	-	V/ns
$t_{d(off)}$	Turn-off delay time	$V_{CC} = 300\text{ V}$ , $L = 1\ \text{mH}$ ,	-	7.5	-	ns
$t_f$	Current fall time	$I_C = 10\text{ A}$ , $V_{GE} = 5\text{ V}$ , $R_G = 1\ \text{k}\Omega$ , $T_J = 150\text{ }^\circ\text{C}$	-	7	-	ns
dV/dt	Turn-off voltage slope	(see Figure 16. Test circuit for inductive load switching)	-	144.7	-	V/ns

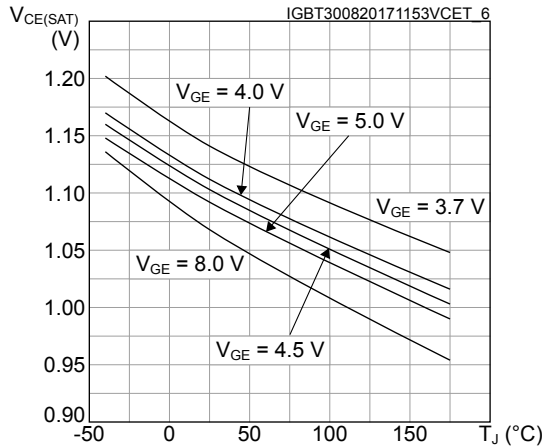
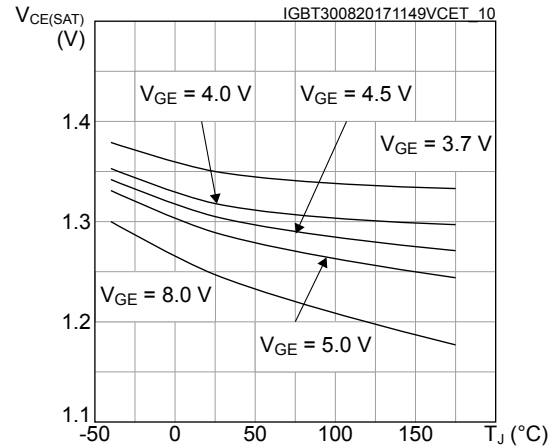
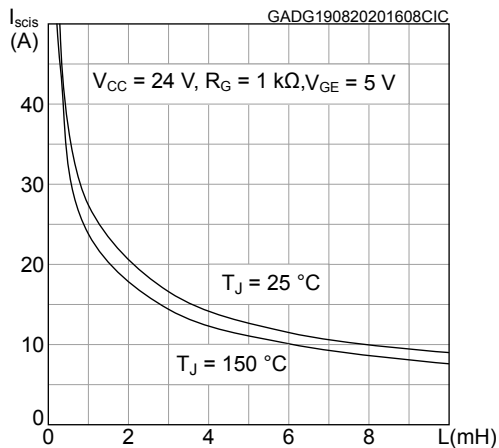
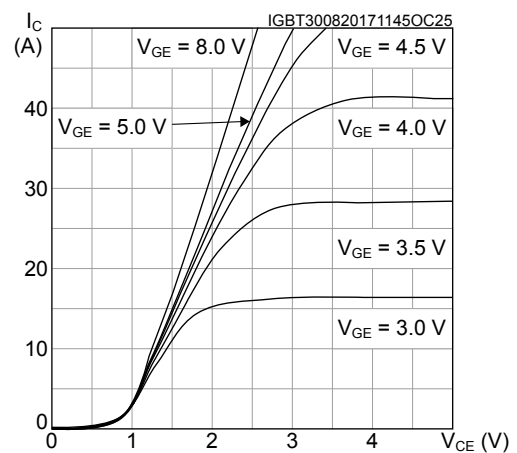
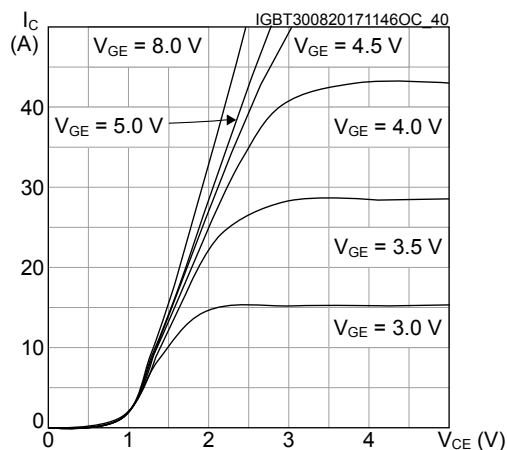
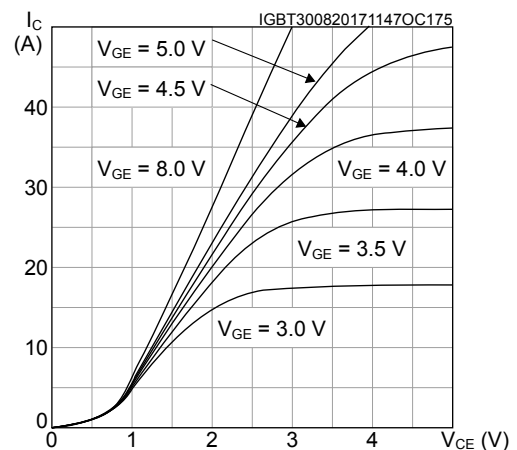
**2.1 Electrical characteristics (curves)**
**Figure 1.  $V_{CE(sat)}$  vs junction temperature ( $I_C = 6\text{ A}$ )**

**Figure 2.  $V_{CE(sat)}$  vs junction temperature ( $I_C = 10\text{ A}$ )**

**Figure 3. Self-clamped inductive switching current**

**Figure 4. Output characteristics ( $T_J = 25\text{ }^{\circ}\text{C}$ )**

**Figure 5. Output characteristics ( $T_J = -40\text{ }^{\circ}\text{C}$ )**

**Figure 6. Output characteristics ( $T_J = 175\text{ }^{\circ}\text{C}$ )**

**Figure 7. Transfer characteristics**

**Figure 8. Collector current vs case temperature**

**Figure 9. Leakage current vs temperature**

**Figure 10. Normalized  $V_{CES(\text{clamped})}$  vs temperature**

**Figure 11. Normalized  $V_{GE(\text{th})}$  vs temperature**

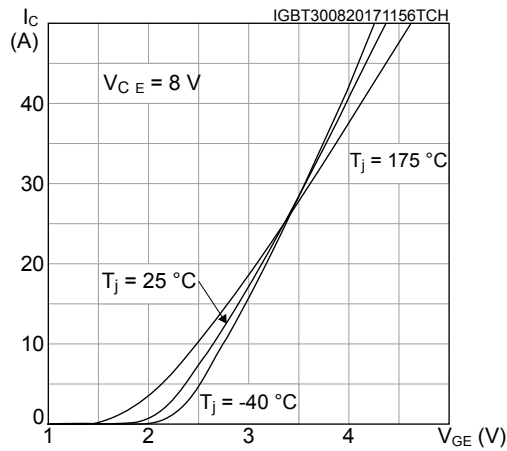
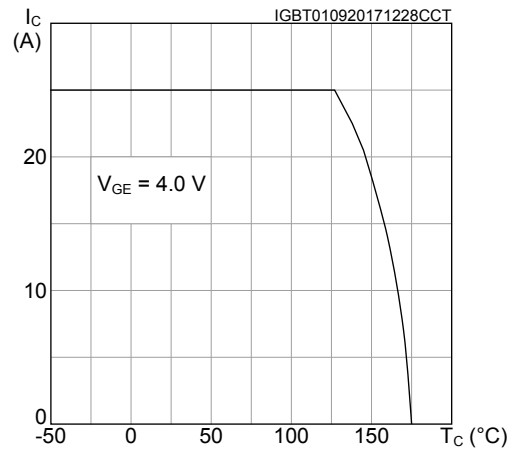
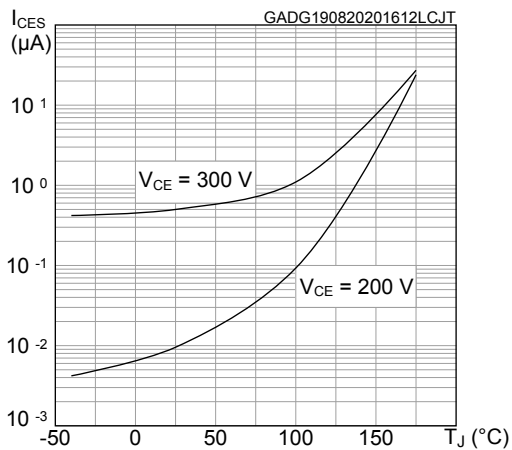
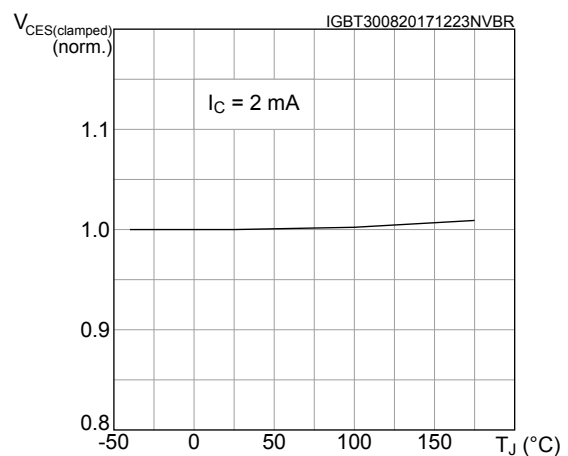
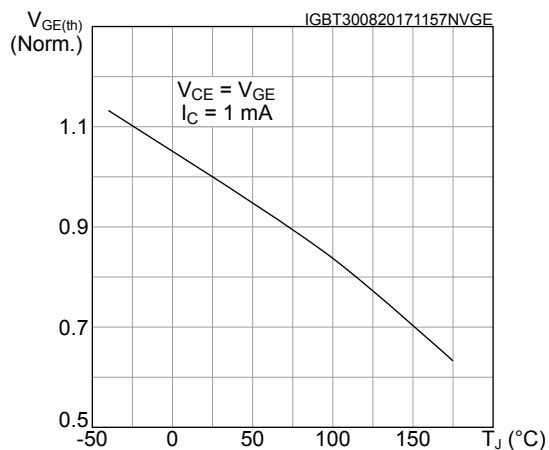
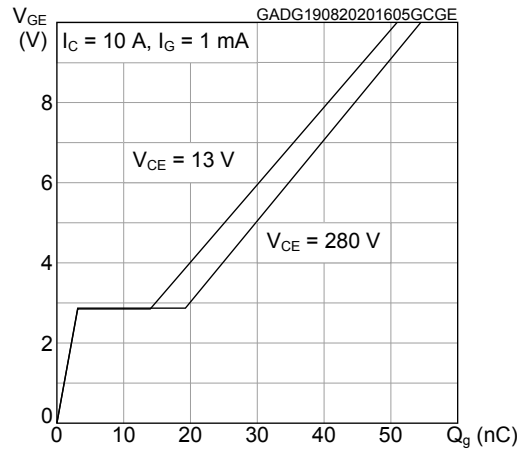
**Figure 12. Gate charge vs gate-emitter voltage**

Figure 13. Capacitance variations

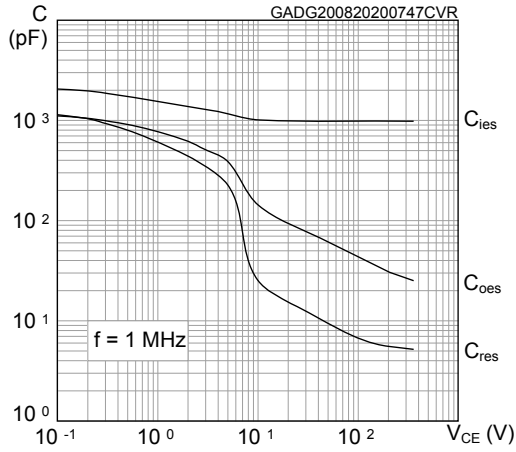

Figure 14. Thermal impedance for D<sup>2</sup>PAK and I<sup>2</sup>PAK

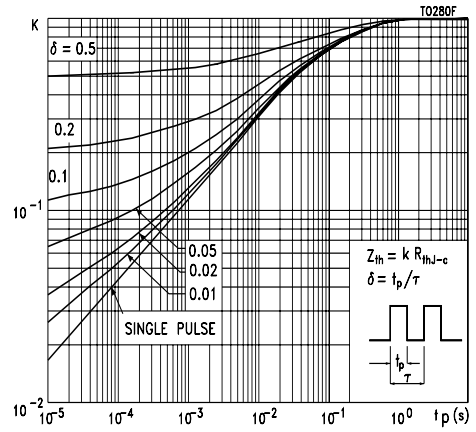
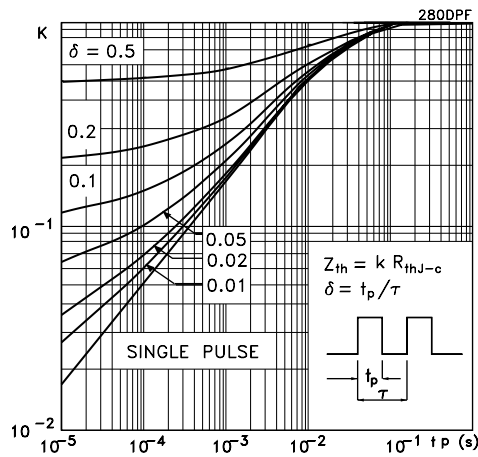

Figure 15. Thermal impedance for DPAK



### 3 Test circuits

Figure 16. Test circuit for inductive load switching

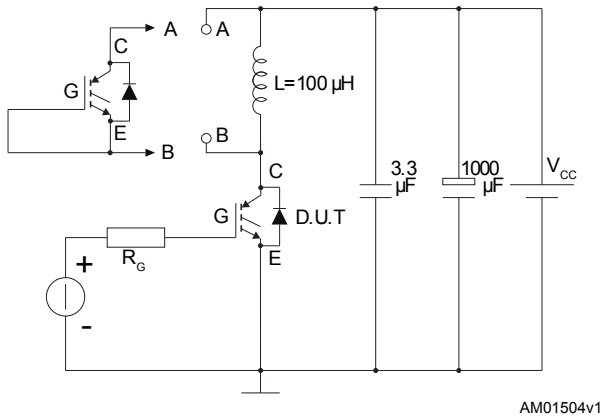

Figure 17. Test circuit for resistive load switching

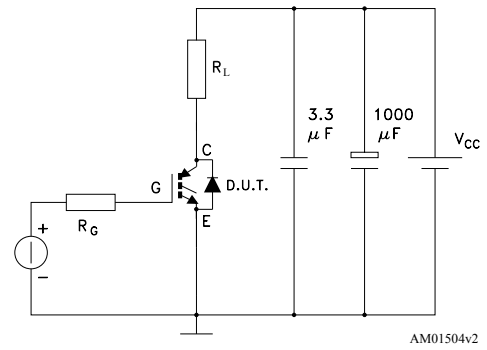

Figure 18. Gate charge test circuit

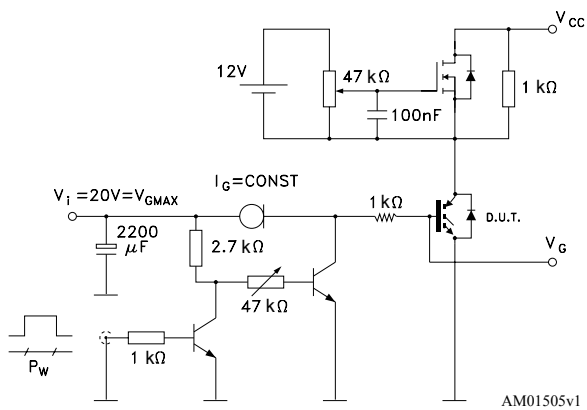
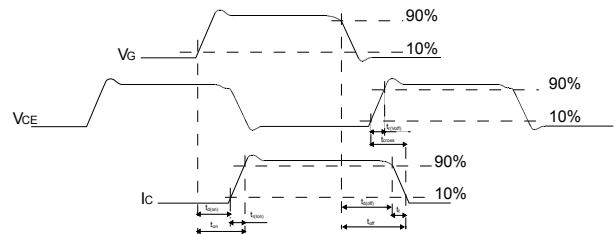

Figure 19. Switching waveform





## 4 Package information

In order to meet environmental requirements, ST offers these devices in different grades of **ECOPACK** packages, depending on their level of environmental compliance. ECOPACK specifications, grade definitions and product status are available at: [www.st.com](http://www.st.com). ECOPACK is an ST trademark.

### 4.1 D<sup>2</sup>PAK (TO-263) type A package information

Figure 20. D<sup>2</sup>PAK (TO-263) type A package outline

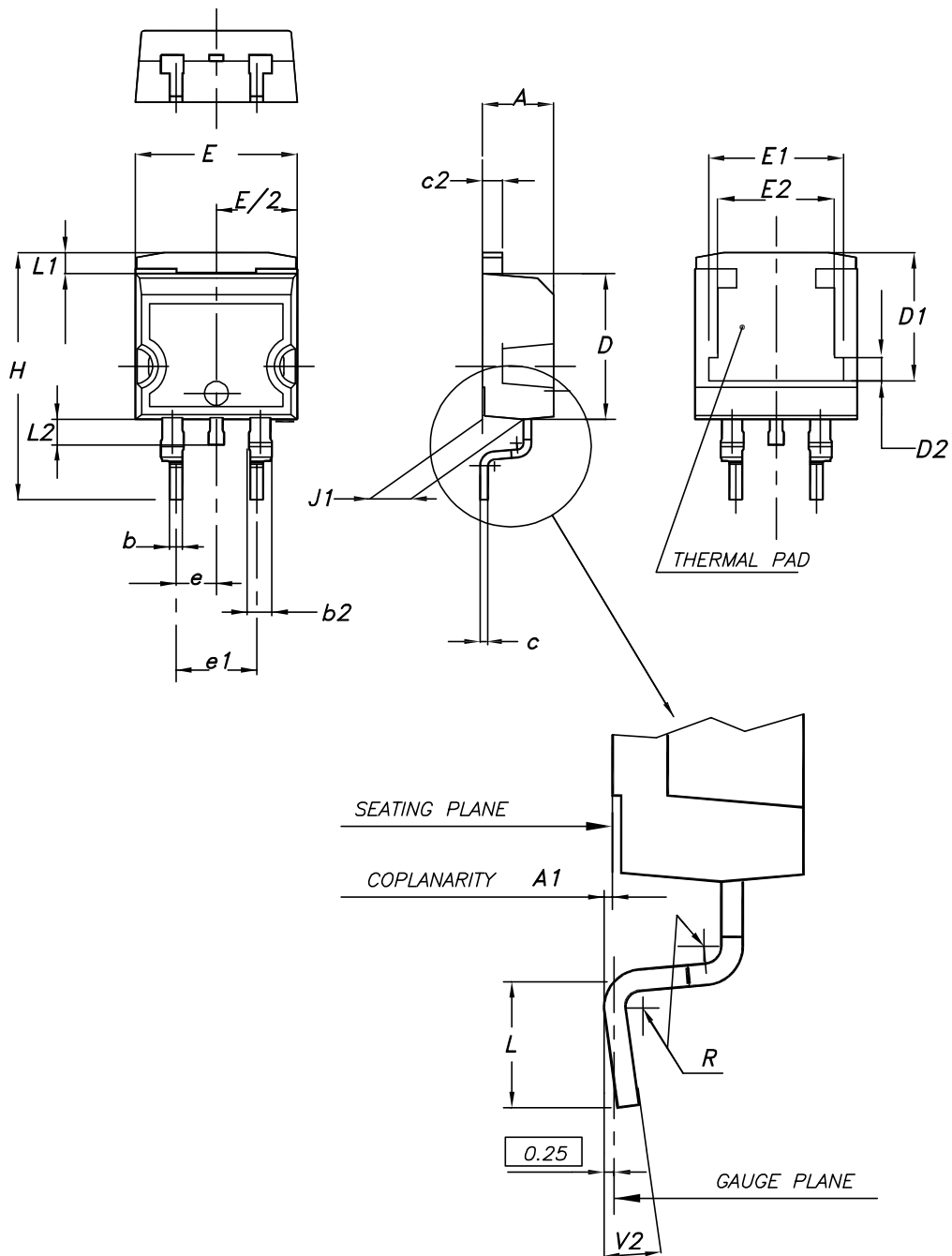

0079457\_26

**Table 7. D<sup>2</sup>PAK (TO-263) type A package mechanical data**

Dim.	mm		
	Min.	Typ.	Max.
A	4.40		4.60
A1	0.03		0.23
b	0.70		0.93
b2	1.14		1.70
c	0.45		0.60
c2	1.23		1.36
D	8.95		9.35
D1	7.50	7.75	8.00
D2	1.10	1.30	1.50
E	10.00		10.40
E1	8.30	8.50	8.70
E2	6.85	7.05	7.25
e		2.54	
e1	4.88		5.28
H	15.00		15.85
J1	2.49		2.69
L	2.29		2.79
L1	1.27		1.40
L2	1.30		1.75
R		0.40	
V2	0°		8°

Figure 21. D<sup>2</sup>PAK (TO-263) recommended footprint (dimensions are in mm)

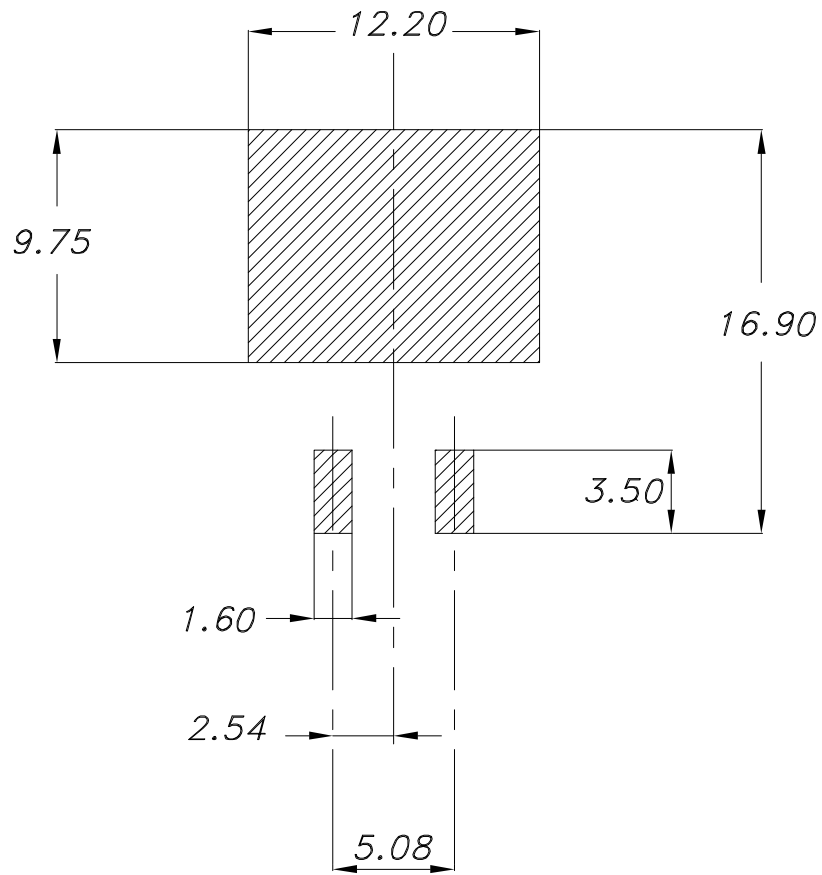

Footprint\_26

## 4.2 DPAK (TO-252) type A2 package information

Figure 22. DPAK (TO-252) type A2 package outline

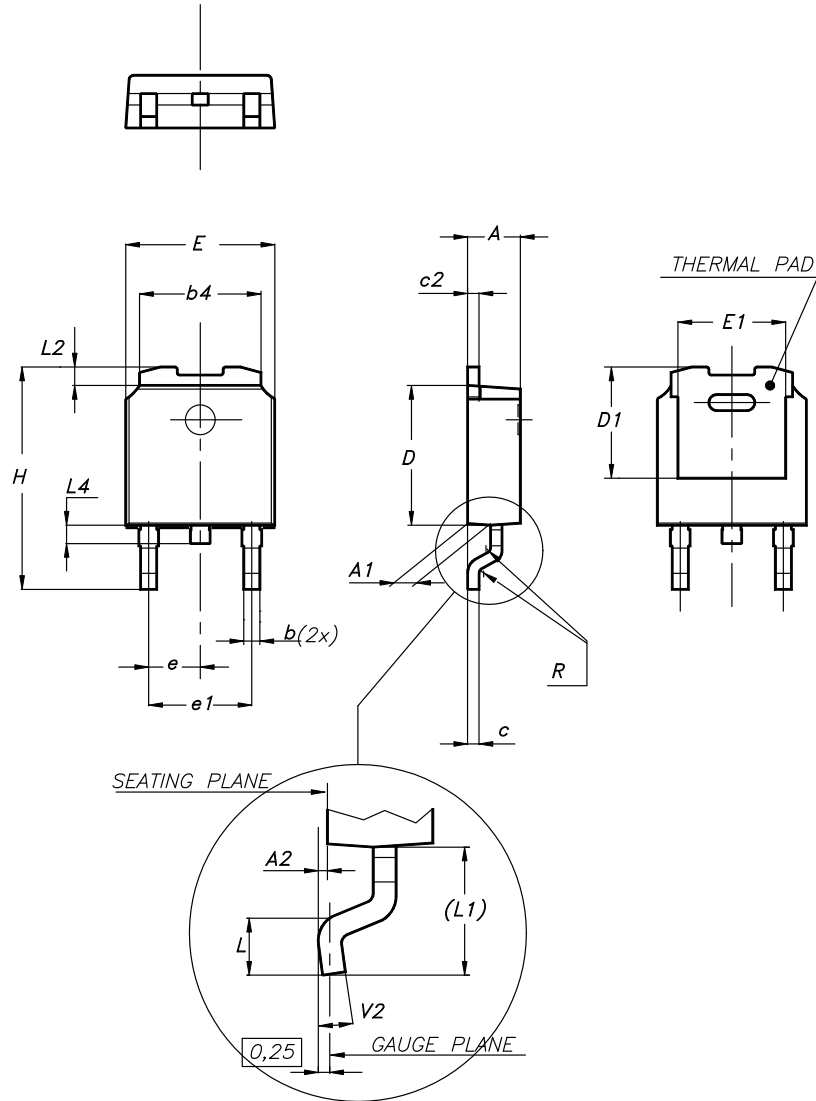

0068772\_type-A2\_rev29

**Table 8. DPAK (TO-252) type A2 mechanical data**

Dim.	mm		
	Min.	Typ.	Max.
A	2.20		2.40
A1	0.90		1.10
A2	0.03		0.23
b	0.64		0.90
b4	5.20		5.40
c	0.45		0.60
c2	0.48		0.60
D	6.00		6.20
D1	4.95	5.10	5.25
E	6.40		6.60
E1	5.10	5.20	5.30
e	2.159	2.286	2.413
e1	4.445	4.572	4.699
H	9.35		10.10
L	1.00		1.50
L1	2.60	2.80	3.00
L2	0.65	0.80	0.95
L4	0.60		1.00
R		0.20	
V2	0°		8°

Figure 23. DPAK (TO-252) recommended footprint (dimensions are in mm)

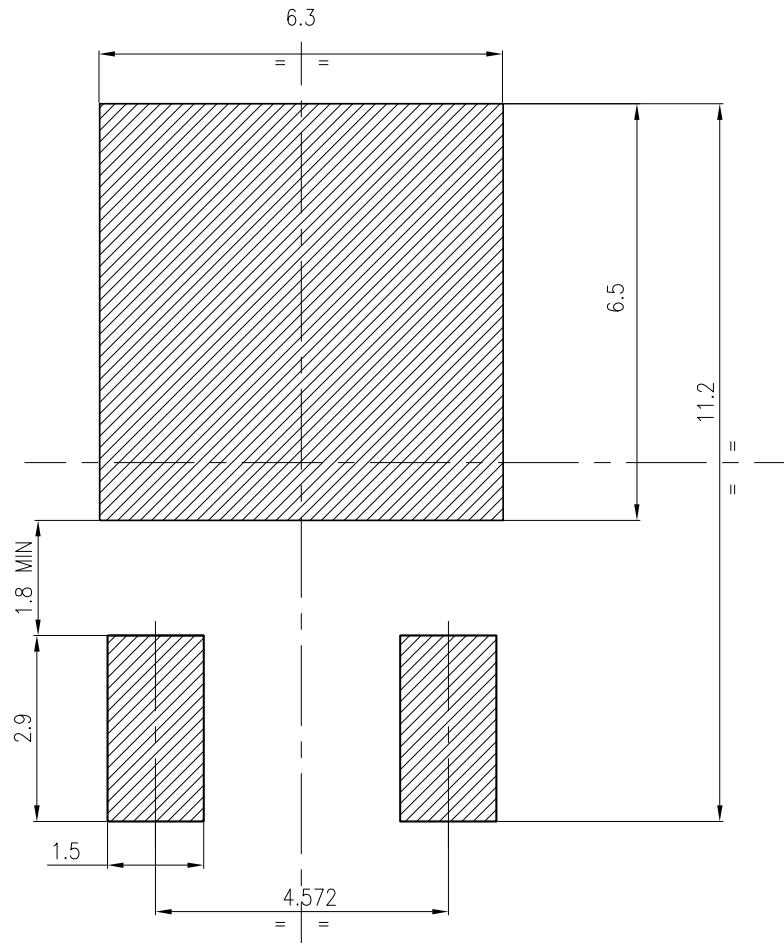

FP\_0068772\_29

### 4.3 I<sup>2</sup>PAK package information

Figure 24. I<sup>2</sup>PAK package outline

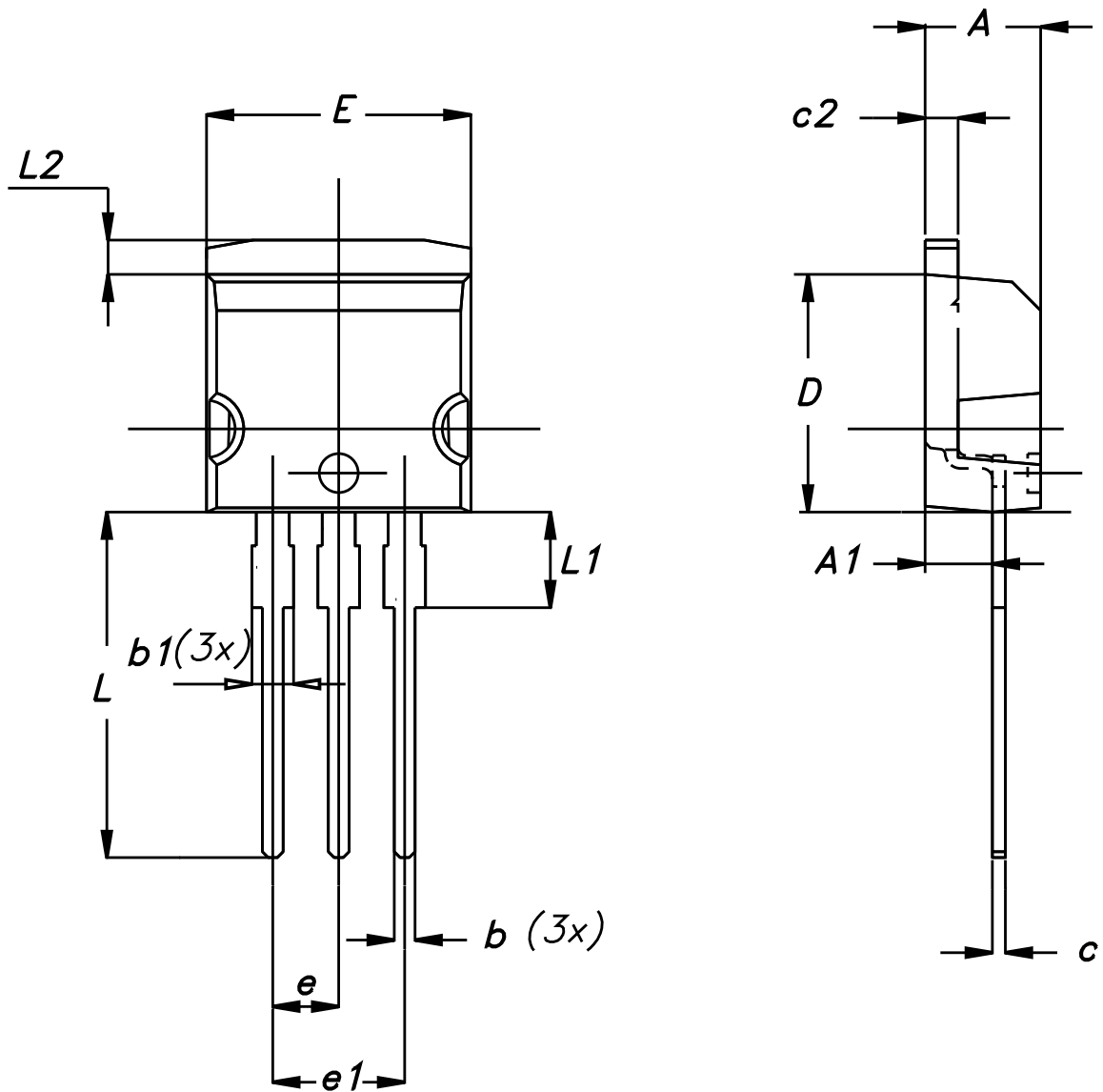

0004982\_Rev\_9

**Table 9. I<sup>2</sup>PAK package mechanical data**

Dim.	mm		
	Min.	Typ.	Max.
A	4.40	-	4.60
A1	2.40	-	2.72
b	0.61	-	0.88
b1	1.14	-	1.70
c	0.49	-	0.70
c2	1.23	-	1.32
D	8.95	-	9.35
e	2.40	-	2.70
e1	4.95	-	5.15
E	10	-	10.40
L	13	-	14
L1	3.50	-	3.93
L2	1.27	-	1.40



#### 4.4 D<sup>2</sup>PAK and DPAK packing information

Figure 25. Tape outline

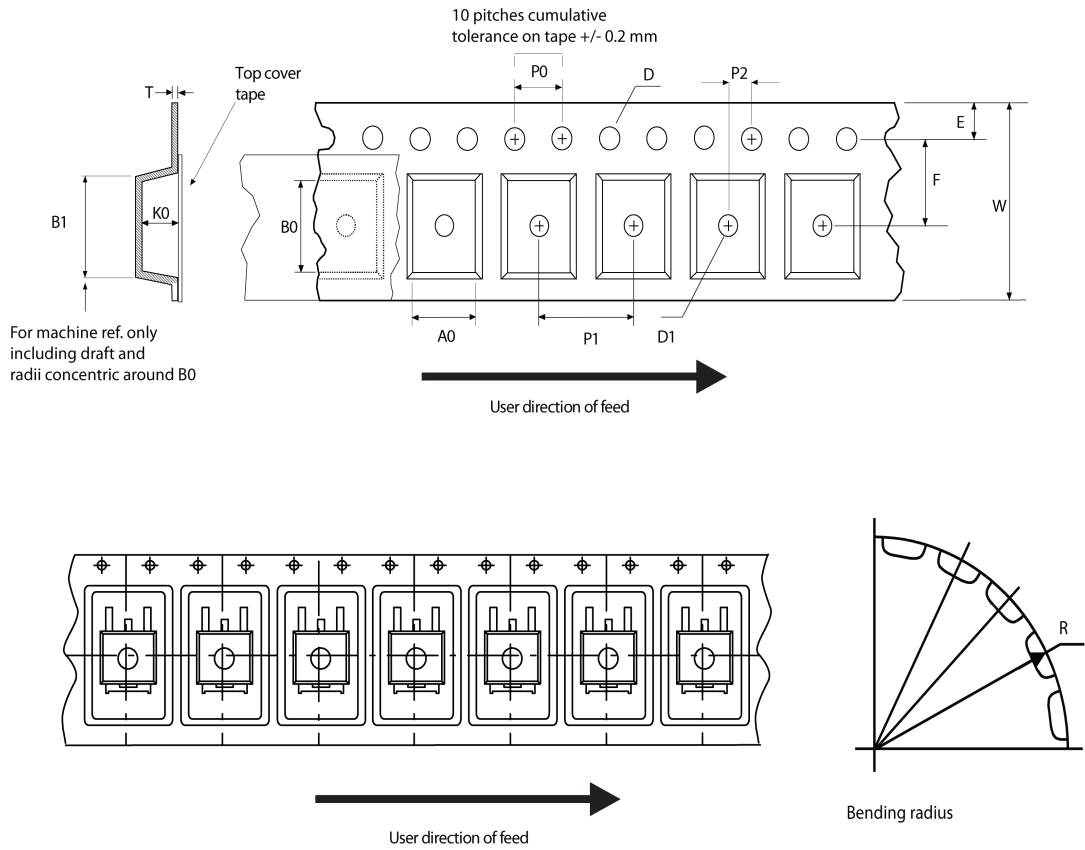

AM08852v1

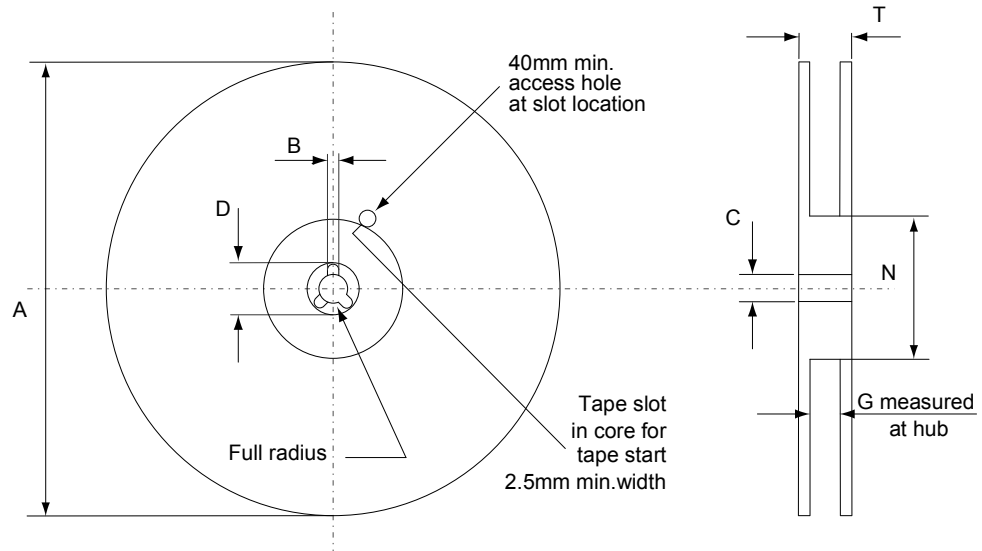
**Figure 26. Reel outline**

AM06038v1

**Table 10. D<sup>2</sup>PAK tape and reel mechanical data**

Tape			Reel			
Dim.	mm		Dim.	mm		
	Min.	Max.		Min.	Max.	
A0	10.5	10.7	A		330	
B0	15.7	15.9	B	1.5		
D	1.5	1.6	C	12.8	13.2	
D1	1.59	1.61	D	20.2		
E	1.65	1.85	G	24.4	26.4	
F	11.4	11.6	N	100		
K0	4.8	5.0	T		30.4	
P0	3.9	4.1	Base quantity Bulk quantity			
P1	11.9	12.1				1000
P2	1.9	2.1				1000
R	50					
T	0.25	0.35				
W	23.7	24.3				

**Table 11. DPAK tape and reel mechanical data**

Tape			Reel		
Dim.	mm		Dim.	mm	
	Min.	Max.		Min.	Max.
A0	6.8	7	A		330
B0	10.4	10.6	B	1.5	
B1		12.1	C	12.8	13.2
D	1.5	1.6	D	20.2	
D1	1.5		G	16.4	18.4
E	1.65	1.85	N	50	
F	7.4	7.6	T		22.4
K0	2.55	2.75			
P0	3.9	4.1	Base qty.		2500
P1	7.9	8.1	Bulk qty.		2500
P2	1.9	2.1			
R	40				
T	0.25	0.35			
W	15.7	16.3			

## 5 Ordering information

**Table 12. Order codes**

Order code	Marking	Package	Packing
STGB25N36LZAG	GB25N36LZ	D <sup>2</sup> PAK	Tape and reel
STGD25N36LZAG	GD25N36LZ	DPAK	Tape and reel
STGI25N36LZAG	GI25N36LZ	I <sup>2</sup> PAK	Tube

## Revision history

**Table 13. Document revision history**

Date	Revision	Changes
19-Aug-2020	1	First release.

## Contents

<b>1</b>	<b>Electrical ratings</b> .....	<b>2</b>
<b>2</b>	<b>Electrical characteristics</b> .....	<b>3</b>
<b>2.1</b>	<b>Electrical characteristics (curves)</b> .....	<b>5</b>
<b>3</b>	<b>Test circuits</b> .....	<b>8</b>
<b>4</b>	<b>Package information</b> .....	<b>9</b>
<b>4.1</b>	<b>D<sup>2</sup>PAK (TO-263) type A package information</b> .....	<b>9</b>
<b>4.2</b>	<b>DPAK (TO-252) type A2 package information</b> .....	<b>12</b>
<b>4.3</b>	<b>I<sup>2</sup>PAK package information</b> .....	<b>15</b>
<b>4.4</b>	<b>D<sup>2</sup>PAK and DPAK packing information</b> .....	<b>17</b>
<b>5</b>	<b>Ordering information</b> .....	<b>20</b>
	<b>Revision history</b> .....	<b>21</b>