



Figure 1: Internal schematic diagram

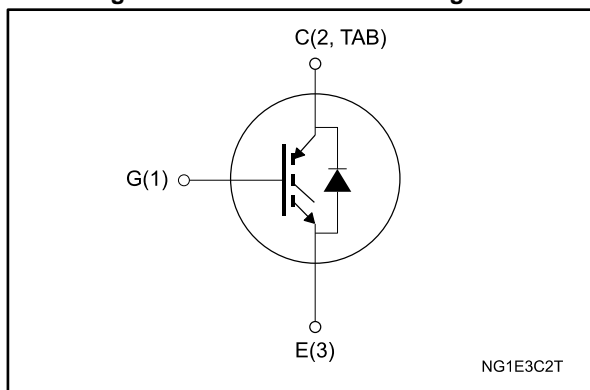

Table 1: Device summary

Order code	Marking	Package	Packing
STGB10NC60KDT4	GB10NC60KD	D ² PAK	Tape and reel
STGD10NC60KDT4	GD10NC60KD	DPAK	
STGF10NC60KD	GF10NC60KD	TO-220FP	Tube
STGP10NC60KD	GP10NC60KD	TO-220	

Features

- Lower on voltage drop ($V_{CE(sat)}$)
- Lower C_{RES} / C_{IES} ratio (no cross-conduction susceptibility)
- Very soft ultra fast recovery antiparallel diode
- Short-circuit withstand time 10 μ s

Applications

- High frequency motor controls
- SMPS and PFC in both hard switch and resonant topologies
- Motor drives

Description

These devices are very fast IGBTs developed using advanced PowerMESH™ technology. This process guarantees an excellent trade-off between switching performance and low on-state behavior. These devices are well-suited for resonant or soft-switching applications.

Contents

1	Electrical ratings	3
2	Electrical characteristics	4
	2.1 Electrical characteristics (curves)	7
3	Test circuits	10
4	Package information	11
	4.1 D ² PAK (TO-263) type A package information	11
	4.2 D ² PAK (TO-263) type B package information	14
	4.3 DPAK (TO-252) type A package information.....	17
	4.4 TO-220FP package information	20
	4.5 TO-220 type A package information.....	22
	4.6 D ² PAK (TO-263) type A packing information	24
	4.7 D ² PAK (TO-263) type B packing information	26
	4.8 DPAK (TO-252) type A tape packing information.....	27
5	Revision history	29

1 Electrical ratings

Table 2: Absolute maximum ratings

Symbol	Parameter	Value			Unit
		D ² PAK, TO-220	DPAK	TO-220FP	
V _{CES}	Collector-emitter voltage (V _{GE} = 0 V)	600			V
I _C ⁽¹⁾	Continuous collector current at T _C = 25 °C	20		9	A
	Continuous collector current at T _C = 100 °C	10		6	A
I _{CL} ⁽²⁾	Turn-off latching current	30			A
I _{CP} ⁽³⁾	Pulsed collector current	30			A
V _{GE}	Gate-emitter voltage	±20			V
I _F	Diode RMS forward current at T _C =25°C	10			A
I _{FSM}	Surge non repetitive forward current t _p = 10 ms sinusoidal	20			A
P _{TOT}	Total dissipation at T _C = 25 °C	65	62	25	W
V _{ISO}	Insulation withstand voltage (RMS) from all three leads to external heat sink (t=1 s; T _C =25 °C)	2500			V
t _{scw}	Short-circuit withstand time V _{CE} = 0.5 V _{CES} , T _J = 125 °C, R _G = 10 Ω, V _{GE} = 12 V	10			µs
T _{stg}	Storage temperature range	- 55 to 150			°C
T _J	Operating junction temperature range				

Notes:

(1) Calculated according to the iterative formula:

$$I_C(T_C) = \frac{T_{j(max)} - T_C}{R_{thj-c} \times V_{CE(sat)(max)}(T_{j(max)}, I_C(T_C))}$$

(2) V_{clamp} = 80 % V_{CES}, V_{GE} = 15 V, R_G = 10 Ω, T_J = 150 °C.

(3) Pulse width limited by maximum junction temperature and turn-off within RBSOA.

Table 3: Thermal data

Symbol	Parameter	Value			Unit
		TO-220, D ² PAK	DPAK	TO-220FP	
R _{thj-case}	Thermal resistance junction-case IGBT	1.9	2	5	°C/W
R _{thj-case}	Thermal resistance junction-case diode	4	4.5	7	
R _{thj-amb}	Thermal resistance junction-ambient	62.5	100	62.5	

2 Electrical characteristics

$T_C = 25\text{ °C}$ unless otherwise specified

Table 4: Static characteristics

Symbol	Parameter	Test conditions	Min.	Typ.	Max.	Unit
$V_{(BR)CES}$	Collector-emitter breakdown voltage	$I_C = 1\text{ mA}$, $V_{GE} = 0\text{ V}$	600			V
$V_{CE(sat)}$	Collector-emitter saturation voltage	$V_{GE} = 15\text{ V}$, $I_C = 5\text{ A}$		2.2	2.5	V
		$V_{GE} = 15\text{ V}$, $I_C = 5\text{ A}$, $T_j = 125\text{ °C}$		1.8		
$V_{GE(th)}$	Gate threshold voltage	$V_{CE} = V_{GE}$, $I_C = 250\text{ }\mu\text{A}$	4.5		6.5	V
I_{CES}	Collector cut-off current	$V_{CE} = 600\text{ V}$, $V_{GE} = 0\text{ V}$			150	μA
		$V_{CE} = 600\text{ V}$, $V_{GE} = 0\text{ V}$, $T_j = 125\text{ °C}$ ⁽¹⁾			1	mA
I_{GES}	Gate-emitter leakage current	$V_{GE} = \pm 20\text{ V}$			± 100	nA
$g_{fs}^{(2)}$	Forward transconductance	$V_{CE} = 15\text{ V}$, $I_C = 5\text{ A}$		15		S

Notes:

⁽¹⁾Defined by design, not subject to production test.

⁽²⁾Pulse test: pulse duration < 300 μs , duty cycle < 2 %.

Table 5: Dynamic characteristics

Symbol	Parameter	Test conditions	Min.	Typ.	Max.	Unit
C_{ies}	Input capacitance	$V_{CE} = 25\text{ V}$, $f = 1\text{ MHz}$, $V_{GE} = 0\text{ V}$	-	380	-	pF
C_{oes}	Output capacitance		-	46	-	
C_{res}	Reverse transfer capacitance		-	8.5	-	
Q_g	Total gate charge	$V_{CE} = 390\text{ V}$, $I_C = 5\text{ A}$, $V_{GE} = 0\text{ to }15\text{ V}$ (see Figure 19: "Gate charge test circuit")	-	19	-	nC
Q_{ge}	Gate-emitter charge		-	5	-	
Q_{gc}	Gate-collector charge		-	9	-	

Table 6: Switching on/off (inductive load)

Symbol	Parameter	Test conditions	Min.	Typ.	Max.	Unit
$t_{d(on)}$	Turn-on delay time	$V_{CC} = 390\text{ V}$, $I_C = 5\text{ A}$, $R_G = 10\ \Omega$, $V_{GE} = 15\text{ V}$ (see Figure 18 : "Test circuit for inductive load switching" and Figure 20 : "Switching waveform")	-	17	-	ns
t_r	Current rise time		-	6	-	ns
$(di/dt)_{on}$	Turn-on current slope		-	655	-	A/ μ s
$t_{d(on)}$	Turn-on delay time	$V_{CC} = 390\text{ V}$, $I_C = 5\text{ A}$, $R_G = 10\ \Omega$, $V_{GE} = 15\text{ V}$, $T_j = 125^\circ\text{C}$ (see Figure 18 : "Test circuit for inductive load switching" and Figure 20 : "Switching waveform")	-	16.5	-	ns
t_r	Current rise time		-	6.5	-	ns
$(di/dt)_{on}$	Turn-on current slope		-	575	-	A/ μ s
$t_{r(voff)}$	Off voltage rise time	$V_{CC} = 390\text{ V}$, $I_C = 5\text{ A}$, $R_G = 10\ \Omega$, $V_{GE} = 15\text{ V}$ (see Figure 18 : "Test circuit for inductive load switching" and Figure 20 : "Switching waveform")	-	33	-	ns
$t_{d(off)}$	Turn-off delay time		-	72	-	ns
t_f	Current fall time		-	82	-	ns
$t_{r(voff)}$	Off voltage rise time	$V_{CC} = 390\text{ V}$, $I_C = 5\text{ A}$, $R_G = 10\ \Omega$, $V_{GE} = 15\text{ V}$, $T_j = 125^\circ\text{C}$ (see Figure 18 : "Test circuit for inductive load switching" and Figure 20 : "Switching waveform")	-	60	-	ns
$t_{d(off)}$	Turn-off delay time		-	106	-	ns
t_f	Current fall time		-	136	-	ns

Table 7: Switching energy (inductive load)

Symbol	Parameter	Test conditions	Min.	Typ.	Max.	Unit
$E_{on(1)}$	Turn-on switching energy	$V_{CC} = 390\text{ V}$, $I_C = 5\text{ A}$, $R_G = 10\ \Omega$, $V_{GE} = 15\text{ V}$ (see Figure 18 : "Test circuit for inductive load switching")	-	55	-	μ J
$E_{off(2)}$	Turn-off switching energy		-	85	-	μ J
E_{ts}	Total switching energy		-	140	-	μ J
$E_{on(1)}$	Turn-on switching energy	$V_{CC} = 390\text{ V}$, $I_C = 5\text{ A}$, $R_G = 10\ \Omega$, $V_{GE} = 15\text{ V}$, $T_j = 125^\circ\text{C}$ (see Figure 18 : "Test circuit for inductive load switching")	-	87	-	μ J
$E_{off(2)}$	Turn-off switching energy		-	162	-	μ J
E_{ts}	Total switching energy		-	249	-	μ J

Notes:

(1)Including the reverse recovery of the diode.

(2)Including the tail of the collector current.

Table 8: Collector-emitter diode

Symbol	Parameter	Test conditions	Min.	Typ.	Max.	Unit
V _F	Forward on-voltage	I _F =5 A	-	2	-	V
		I _F =5 A, T _j =125 °C	-	1.6	-	V
t _{rr}	Reverse recovery time	I _F =5 A, V _R =40 V, di/dt=100 A/μs (see Figure 21: "Diode reverse recovery waveform")	-	22	-	ns
Q _{rr}	Reverse recovery charge		-	14	-	nC
I _{rrm}	Reverse recovery current		-	1.3	-	A
t _{rr}	Reverse recovery time	I _F =5 A, V _R =40 V, T _j =125 °C, di/dt=100 A/μs (see Figure 21: "Diode reverse recovery waveform")	-	35	-	ns
Q _{rr}	Reverse recovery charge		-	40	-	nC
I _{rrm}	Reverse recovery current		-	2.2	-	A

2.1 Electrical characteristics (curves)

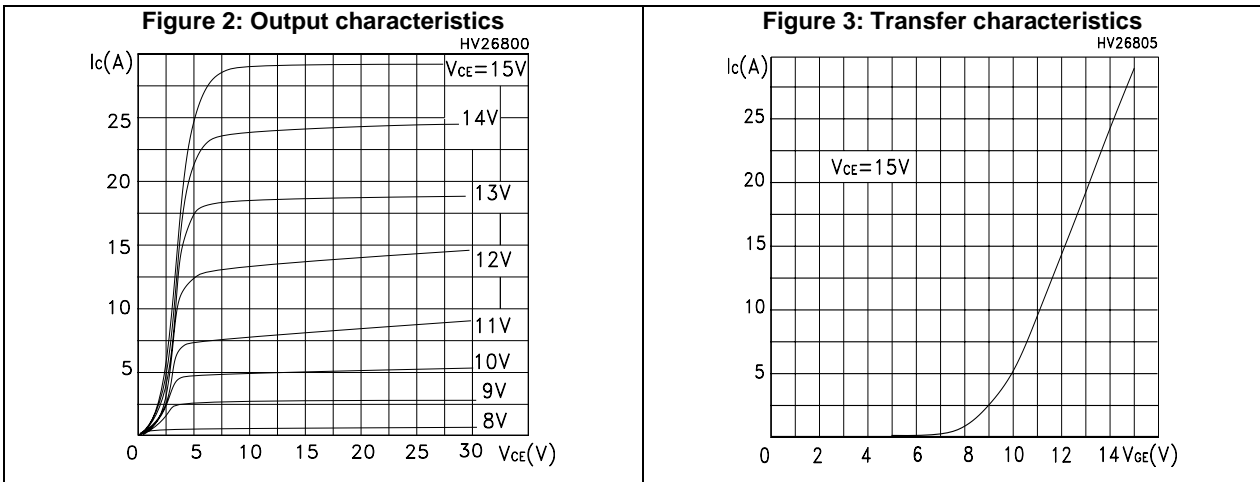

Figure 8: Normalized gate threshold voltage vs temperature

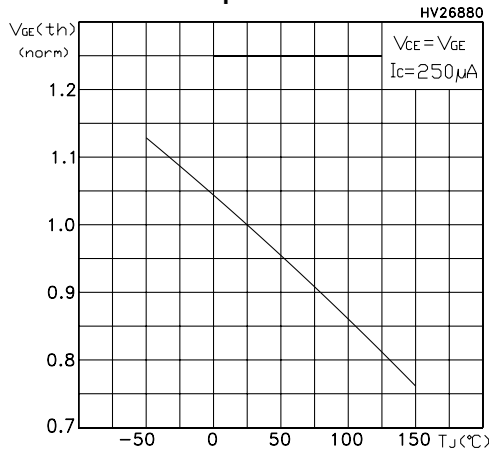

Figure 9: Collector-emitter on voltage vs collector current

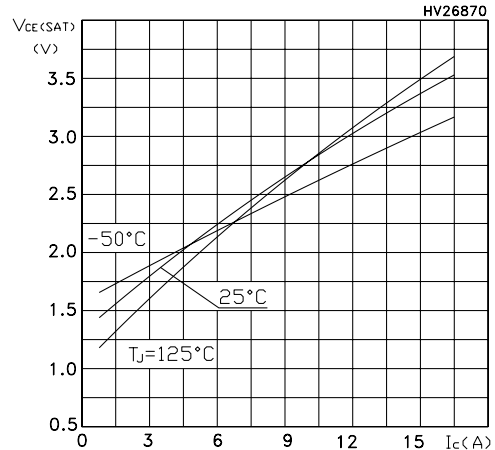

Figure 10: Normalized breakdown voltage vs temperature

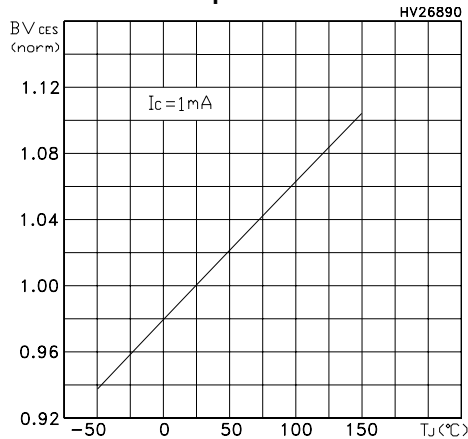

Figure 11: Switching energy vs temperature

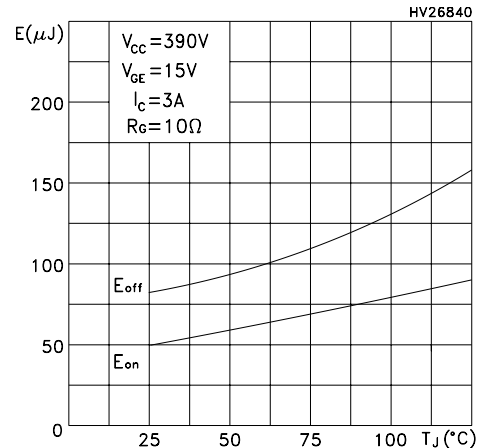

Figure 12: Switching energy vs gate resistance

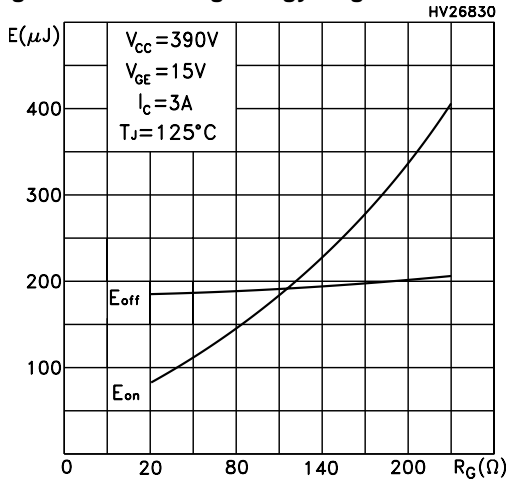

Figure 13: Switching energy vs collector current

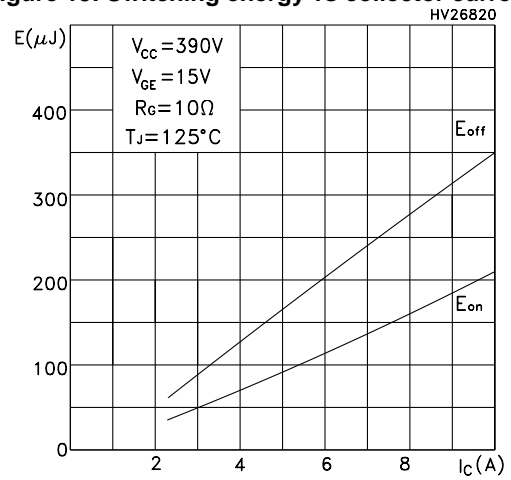

Figure 14: Thermal impedance for D²PAK, DPAK and TO-220

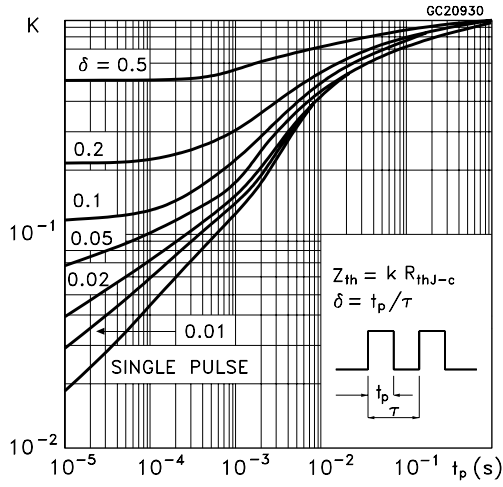

Figure 15: Turn-off SOA

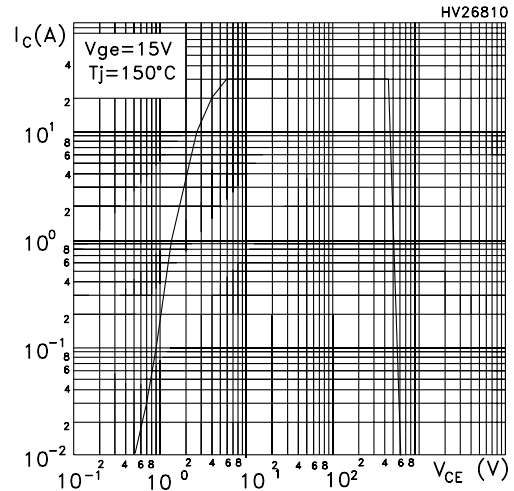

Figure 16: Emitter-collector diode characteristics

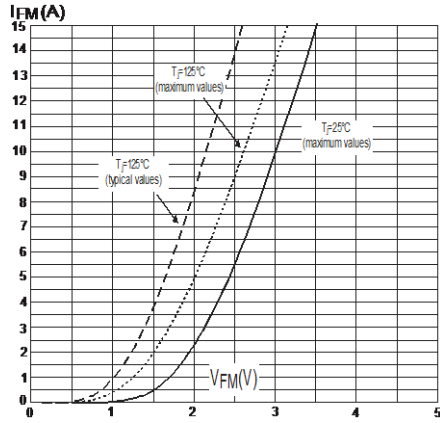
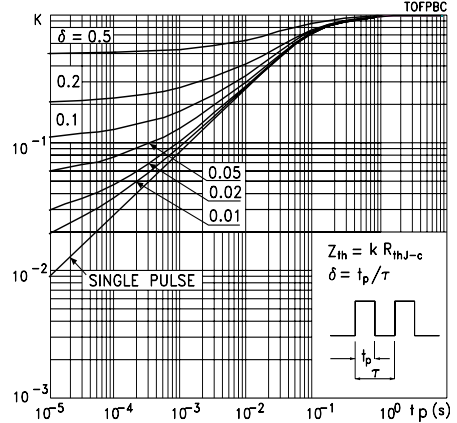
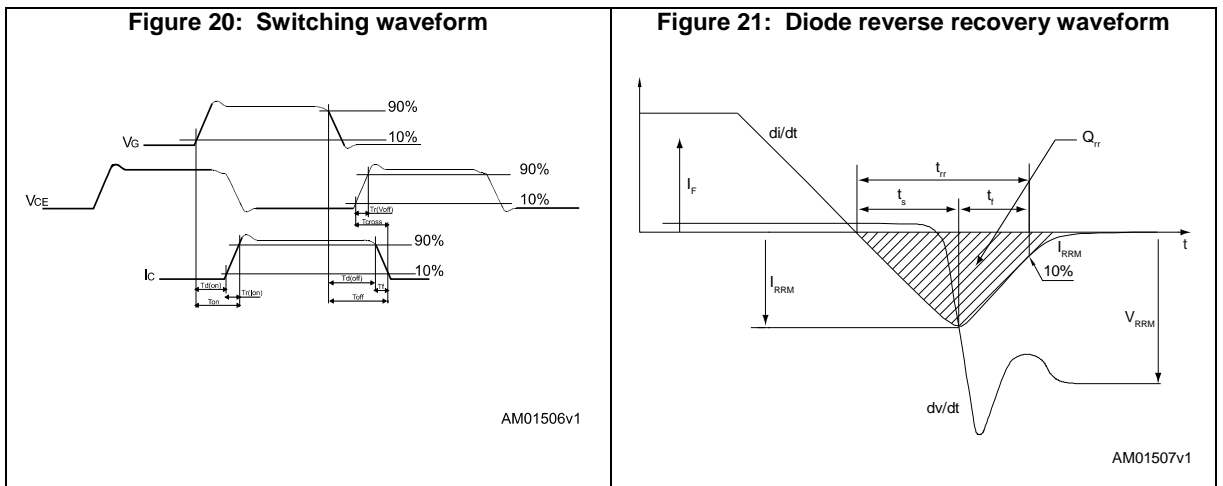
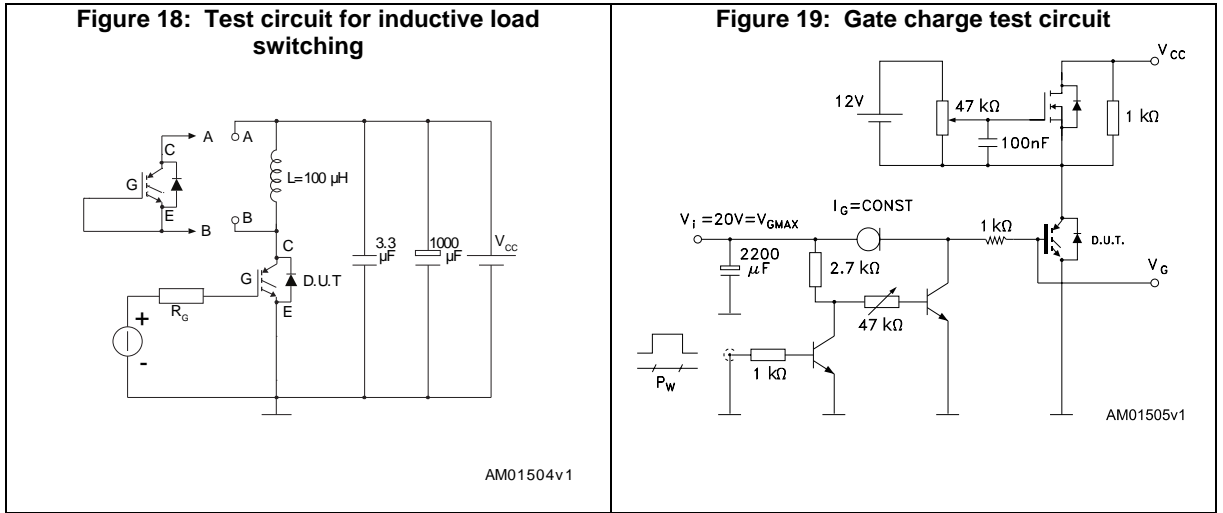

Figure 17: Thermal impedance for TO-220FP



3 Test circuits



4 Package information

In order to meet environmental requirements, ST offers these devices in different grades of ECOPACK® packages, depending on their level of environmental compliance. ECOPACK® specifications, grade definitions and product status are available at: www.st.com. ECOPACK® is an ST trademark.

4.1 D²PAK (TO-263) type A package information

Figure 22: D²PAK (TO-263) type A package outline



Table 9: D²PAK (TO-263) type A package mechanical data

Dim.	mm		
	Min.	Typ.	Max.
A	4.40		4.60
A1	0.03		0.23
b	0.70		0.93
b2	1.14		1.70
c	0.45		0.60
c2	1.23		1.36
D	8.95		9.35
D1	7.50	7.75	8.00
D2	1.10	1.30	1.50
E	10.00		10.40
E1	8.50	8.70	8.90
E2	6.85	7.05	7.25
e		2.54	
e1	4.88		5.28
H	15.00		15.85
J1	2.49		2.69
L	2.29		2.79
L1	1.27		1.40
L2	1.30		1.75
R		0.40	
V2	0°		8°

Figure 23: D²PAK (TO-263) type A recommended footprint (dimensions are in mm)



Footprint

4.2 D²PAK (TO-263) type B package information

Figure 24: D²PAK (TO-263) type B package outline



Table 10: D²PAK (TO-263) type B mechanical data

Dim.	mm		
	Min.	Typ.	Max.
A	4.36		4.56
A1	0		0.25
b	0.70		0.90
b1	0.51		0.89
b2	1.17		1.37
b3	1.36		1.46
c	0.38		0.694
c1	0.38		0.534
c2	1.19		1.34
D	8.60		9.00
D1	6.90		7.50
E	10.15		10.55
E1	8.10		8.70
e	2.54 BSC		
H	15.00		15.60
L	1.90		2.50
L1			1.65
L2			1.78
L3		0.25	
L4	4.78		5.28

Figure 25: D²PAK (TO-263) type B recommended footprint (dimensions are in mm)

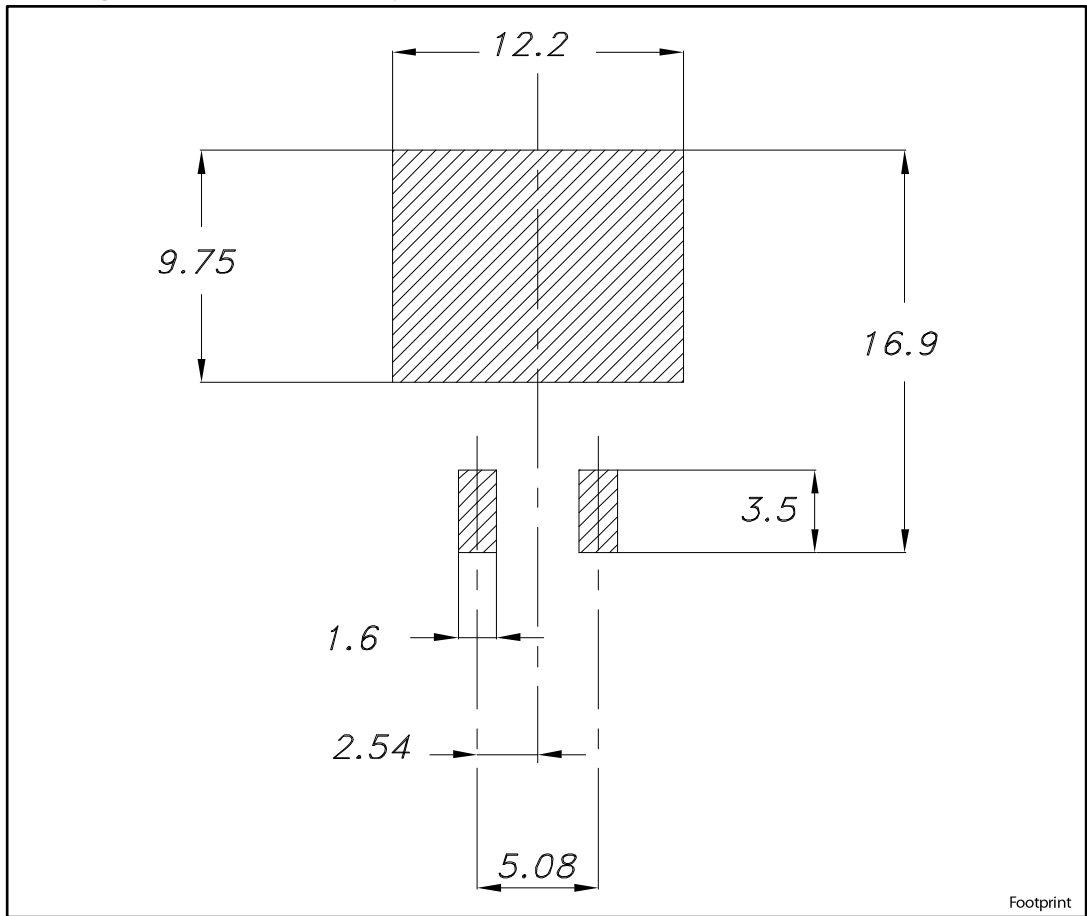

Footprint

4.3 DPAK (TO-252) type A package information

Figure 26: DPAK (TO-252) type A package outline



Table 11: DPAK (TO-252) type A mechanical data

Dim.	mm		
	Min.	Typ.	Max.
A	2.20		2.40
A1	0.90		1.10
A2	0.03		0.23
b	0.64		0.90
b4	5.20		5.40
c	0.45		0.60
c2	0.48		0.60
D	6.00		6.20
D1	4.95	5.10	5.25
E	6.40		6.60
E1	4.60	4.70	4.80
e	2.16	2.28	2.40
e1	4.40		4.60
H	9.35		10.10
L	1.00		1.50
(L1)	2.60	2.80	3.00
L2	0.65	0.80	0.95
L4	0.60		1.00
R		0.20	
V2	0°		8°

Figure 27: DPAK (TO-252) type A recommended footprint (dimensions are in mm)

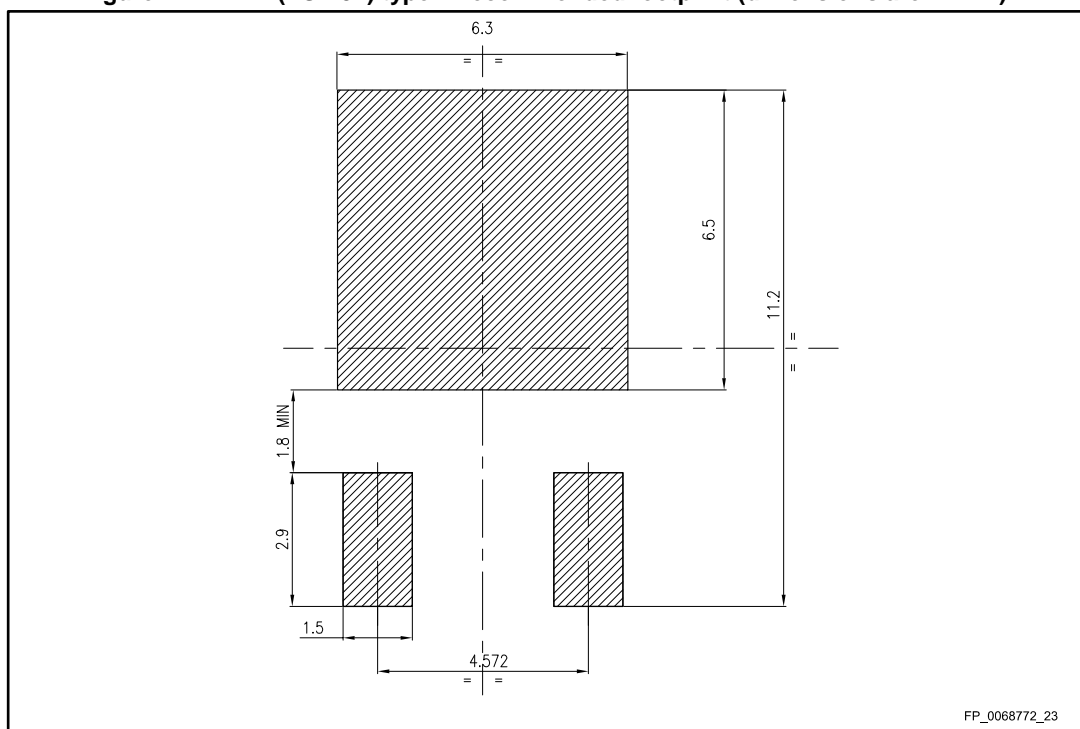

4.4 TO-220FP package information

Figure 28: TO-220FP package outline



7012510_Rev_12_B

Table 12: TO-220FP package mechanical data

Dim.	mm		
	Min.	Typ.	Max.
A	4.4		4.6
B	2.5		2.7
D	2.5		2.75
E	0.45		0.7
F	0.75		1
F1	1.15		1.70
F2	1.15		1.70
G	4.95		5.2
G1	2.4		2.7
H	10		10.4
L2		16	
L3	28.6		30.6
L4	9.8		10.6
L5	2.9		3.6
L6	15.9		16.4
L7	9		9.3
Dia	3		3.2

4.5 TO-220 type A package information

Figure 29: TO-220 type A package outline



0015988_typeA_Rev_21

Table 13: TO-220 type A package mechanical data

Dim.	mm		
	Min.	Typ.	Max.
A	4.40		4.60
b	0.61		0.88
b1	1.14		1.55
c	0.48		0.70
D	15.25		15.75
D1		1.27	
E	10.00		10.40
e	2.40		2.70
e1	4.95		5.15
F	1.23		1.32
H1	6.20		6.60
J1	2.40		2.72
L	13.00		14.00
L1	3.50		3.93
L20		16.40	
L30		28.90	
øP	3.75		3.85
Q	2.65		2.95

4.6 D²PAK (TO-263) type A packing information

Figure 30: D²PAK type A tape outline

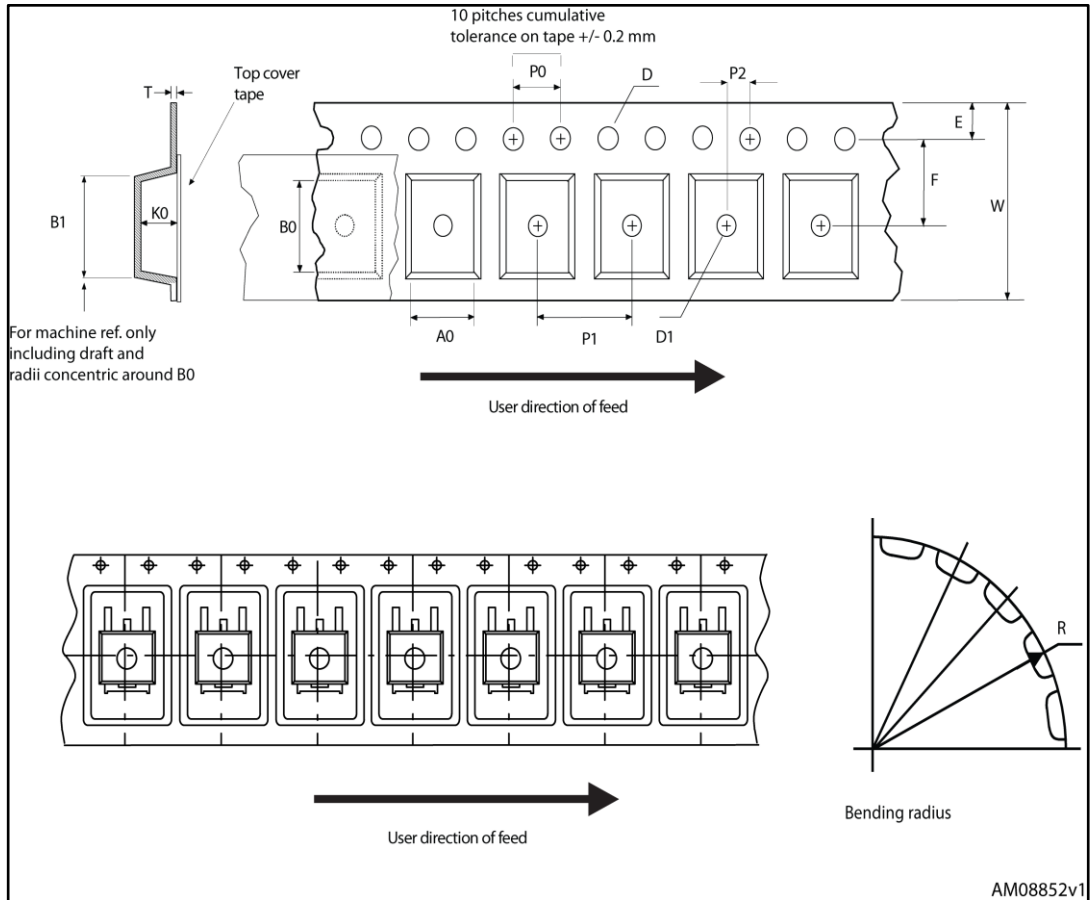

Figure 31: D2PAK type A reel outline

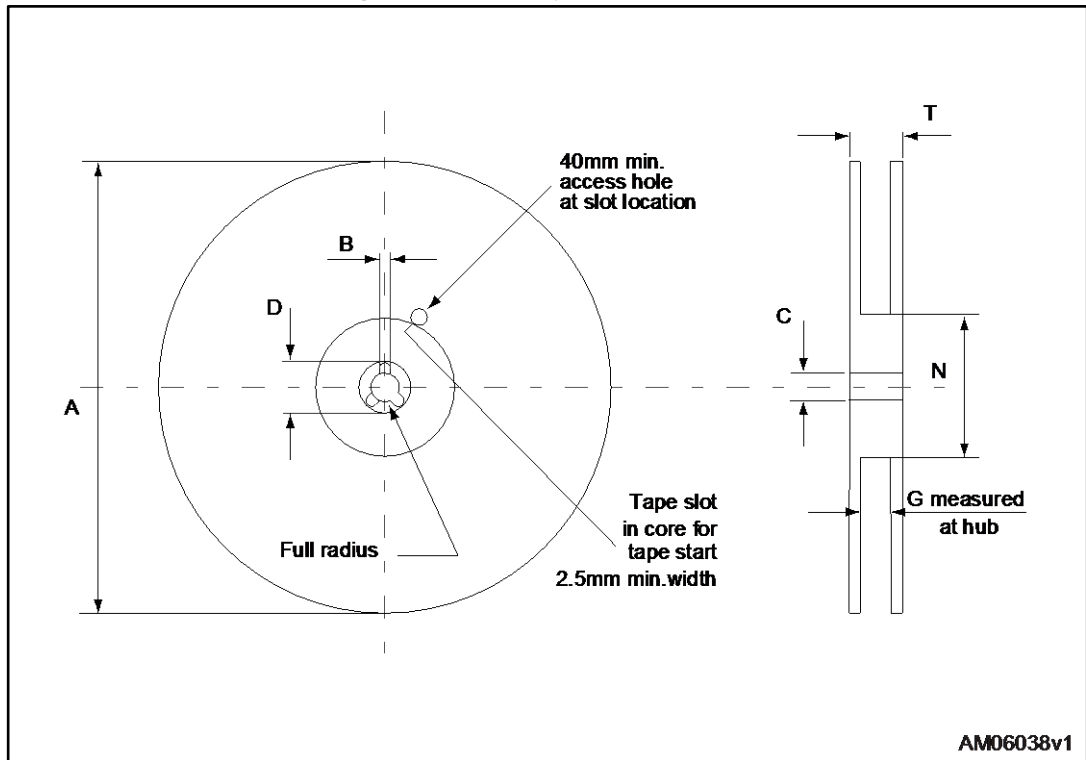

Table 14: D²PAK type A tape and reel mechanical data

Tape			Reel		
Dim.	mm		Dim.	mm	
	Min.	Max.		Min.	Max.
A0	10.5	10.7	A		330
B0	15.7	15.9	B	1.5	
D	1.5	1.6	C	12.8	13.2
D1	1.59	1.61	D	20.2	
E	1.65	1.85	G	24.4	26.4
F	11.4	11.6	N	100	
K0	4.8	5.0	T		30.4
P0	3.9	4.1			
P1	11.9	12.1	Base quantity		1000
P2	1.9	2.1	Bulk quantity		1000
R	50				
T	0.25	0.35			
W	23.7	24.3			

4.7 D²PAK (TO-263) type B packing information

Figure 32: D2PAK type B tape outline

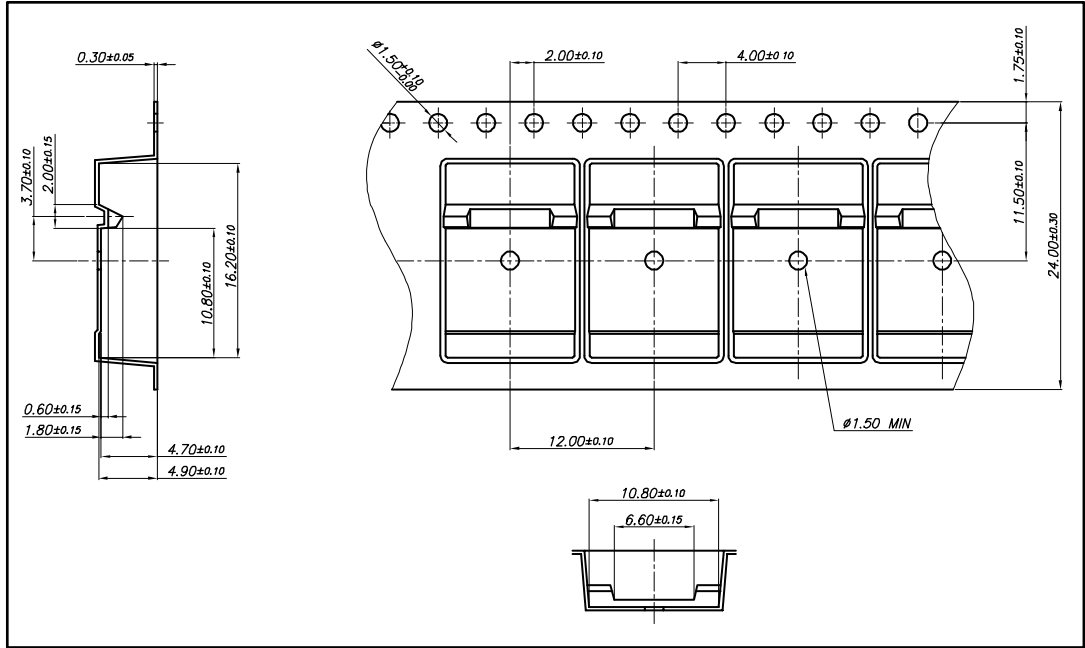
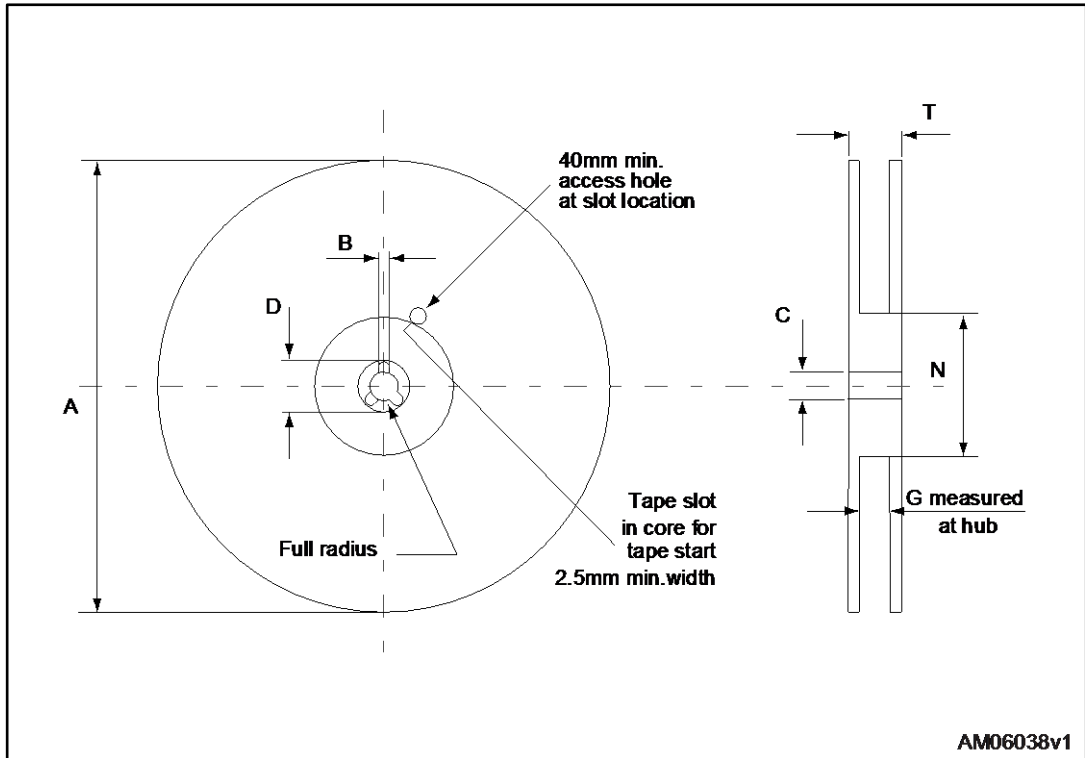

Figure 33: D2PAK type B reel outline



AM06038v1

Table 15: D²PAK type B reel mechanical data

Dim.	mm	
	Min.	Max.
A		330
B	1.5	
C	12.8	13.2
D	20.2	
G	24.4	26.4
N	100	
T		30.4

4.8 DPAK (TO-252) type A tape packing information

Figure 34: DPAK (TO-252) tape outline



Figure 35: DPAK (TO-252) reel outline

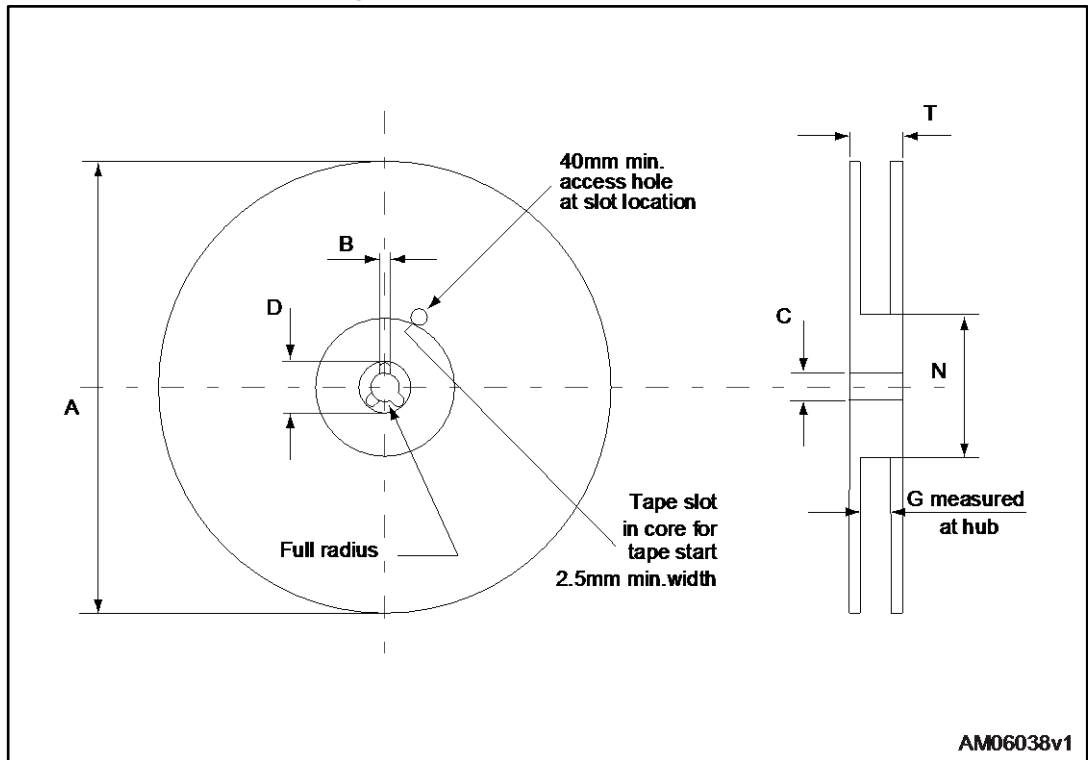

AM06038v1

Table 16: DPAK (TO-252) tape and reel mechanical data

Tape			Reel		
Dim.	mm		Dim.	mm	
	Min.	Max.		Min.	Max.
A0	6.8	7	A		330
B0	10.4	10.6	B	1.5	
B1		12.1	C	12.8	13.2
D	1.5	1.6	D	20.2	
D1	1.5		G	16.4	18.4
E	1.65	1.85	N	50	
F	7.4	7.6	T		22.4
K0	2.55	2.75			
P0	3.9	4.1	Base qty.		2500
P1	7.9	8.1	Bulk qty.		2500
P2	1.9	2.1			
R	40				
T	0.25	0.35			
W	15.7	16.3			

5 Revision history

Table 17: Document revision history

Date	Revision	Changes
14-Jun-2005	1	First release.
19-Jul-2005	2	Complete version.
27-Jan-2006	3	Inserted ecopack indication.
01-Mar-2006	4	The document has been reformatted.
08-Feb-2007	5	Modified value on <i>Table 6.: Switching on/off (inductive load)</i> .
24-Nov-2009	6	Inserted DPAK package option.
06-Jun-2017	7	Modified part numbers on cover page. Updated Section 4: "Package information" . Minor text changes.