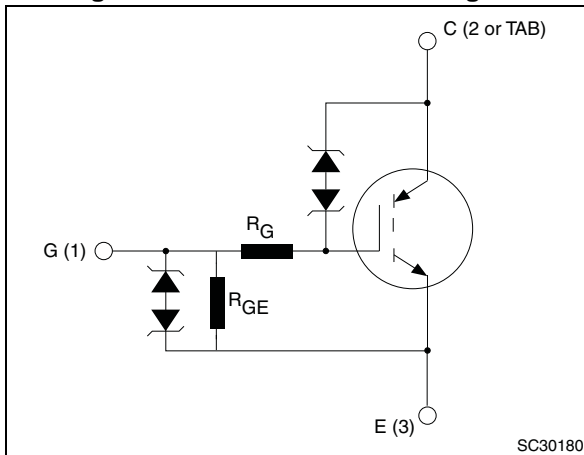

Figure 1. Internal schematic diagram



### Features

- Designed for automotive applications and AEC-Q101 qualified
- ESD gate-emitter protection
- Gate-collector high voltage clamping
- Logic level gate drive
- Low saturation voltage
- High pulsed current capability
- Gate and gate-emitter resistor

### Applications

- Pencil coil electronic ignition driver

### Description

This application-specific IGBT utilizes the most advanced PowerMESH™ technology. The built-in Zener diodes between gate-collector and gate-emitter provide overvoltage protection capabilities. The device also exhibits low on-state voltage drop and low threshold drive for use in automotive ignition systems.

Table 1. Device summary

Order codes	Marking	Packages	Packaging
STGB20N40LZ	GB20N40LZ	D <sup>2</sup> PAK	Tape and reel
STGD20N40LZ	GD20N40LZ	DPAK	Tape and reel

# Contents

<b>1</b>	<b>Electrical ratings</b> .....	<b>3</b>
<b>2</b>	<b>Electrical characteristics</b> .....	<b>4</b>
2.1	Electrical characteristics (curves) .....	6
<b>3</b>	<b>Test circuits</b> .....	<b>9</b>
<b>4</b>	<b>Package mechanical data</b> .....	<b>10</b>
<b>5</b>	<b>Packaging mechanical data</b> .....	<b>16</b>
<b>6</b>	<b>Revision history</b> .....	<b>19</b>

# 1 Electrical ratings

**Table 2. Absolute maximum ratings**

Symbol	Parameter	Value		Unit
		DPAK	D <sup>2</sup> PAK	
V <sub>CES</sub>	Collector-emitter voltage (V <sub>GE</sub> = 0)	V <sub>CES(clamped)</sub>		V
V <sub>ECS</sub>	Emitter collector voltage (V <sub>GE</sub> = 0)	20		V
I <sub>C</sub>	Collector current (continuous) at T <sub>C</sub> = 100 °C	25		A
I <sub>CP</sub> <sup>(1)</sup>	Pulsed collector current	40		A
V <sub>GE</sub>	Gate-emitter voltage	V <sub>GE(clamped)</sub>		V
P <sub>TOT</sub>	Total dissipation at T <sub>C</sub> = 25 °C	125	150	W
E <sub>SCIS</sub>	Single pulse energy T <sub>C</sub> = 25 °C, L = 3 mH, V <sub>CC</sub> = 50 V	300		mJ
E <sub>SCIS</sub>	Single pulse energy T <sub>C</sub> = 150 °C, L = 3 mH, V <sub>CC</sub> = 50 V	180		mJ
ESD	Human body model, R = 1.5 kΩ, C = 100 pF	8		kV
	Machine model, R = 0, C = 100 pF	600		V
	Charged device model	4		kV
T <sub>stg</sub>	Storage temperature	- 55 to 175		°C
T <sub>j</sub>	Operating junction temperature			

1. Pulse width limited by maximum junction temperature.

**Table 3. Thermal data**

Symbol	Parameter	Value		Unit
		DPAK	D <sup>2</sup> PAK	
R <sub>thj-case</sub>	Thermal resistance junction-case	1.2	1	°C/W
R <sub>thj-amb</sub>	Thermal resistance junction-ambient	100	62.5	°C/W

## 2 Electrical characteristics

$T_J = 25\text{ °C}$  unless otherwise specified.

**Table 4. Static electrical characteristics**

Symbol	Parameter	Test conditions	Min.	Typ.	Max.	Unit
$V_{CES(\text{clamped})}$	Collector emitter clamped voltage ( $V_{GE} = 0$ )	$I_C = 2\text{ mA}$		390		V
		$I_C = 2\text{ mA}, T_J = -40\text{ °C to }175\text{ °C}$	365		425	V
$V_{ECS}$	Emitter collector break-down voltage ( $V_{GE} = 0$ )	$I_C = 75\text{ mA}$		28		V
		$I_C = 75\text{ mA}, T_J = -40\text{ °C to }175\text{ °C}$	20			V
$V_{GE(\text{clamped})}$	Gate emitter clamped voltage	$I_G = \pm 2\text{ mA}, T_J = -40\text{ °C to }175\text{ °C}$	12		16	V
$I_{CES}$	Collector cut-off current ( $V_{GE} = 0$ )	$V_{CE} = 15\text{ V}, T_J = 175\text{ °C}$			20	$\mu\text{A}$
		$V_{CE} = 200\text{ V}, T_J = 175\text{ °C}$			100	$\mu\text{A}$
$I_{GES}$	Gate-emitter leakage current ( $V_{CE} = 0$ )	$V_{GE} = \pm 10\text{ V}$		625		$\mu\text{A}$
		$V_{GE} = \pm 10\text{ V}, T_J = -40\text{ °C to }175\text{ °C}$	450		900	$\mu\text{A}$
$R_{GE}$	Gate emitter resistance		11	16	22	$\text{k}\Omega$
$R_G$	Gate resistance			100		$\Omega$
$V_{GE(\text{th})}$	Gate threshold voltage	$V_{GE} = V_{CE}, I_C = 1\text{ mA}$	1.5	1.95	2.5	V
		$V_{GE} = V_{CE}, I_C = 1\text{ mA}, T_J = 175\text{ °C}$	0.85	1.3	1.7	V
$V_{CE(\text{sat})}$	Collector emitter saturation voltage	$V_{GE} = 4.5\text{ V}, I_C = 10\text{ A}, T_J = 175\text{ °C}$		1.5	1.8	V
		$V_{GE} = 4\text{ V}, I_C = 6\text{ A},$		1.30	1.6	V
$g_{fe}$	Forward transconductance	$V_{CE} = 25\text{ V}, I_C = 10\text{ A}$		10.3		S

**Table 5. Dynamic electrical characteristics**

Symbol	Parameter	Test conditions	Min.	Typ.	Max.	Unit
$C_{ies}$	Input capacitance	$V_{CE} = 25\text{ V}, f = 1\text{ MHz}, V_{GE} = 0$	-	910	-	pF
$C_{oes}$	Output capacitance		-	70	-	pF
$C_{res}$	Reverse transfer capacitance		-	10	-	pF
$Q_g$	Gate charge	$V_{CE} = 280\text{ V}, I_C = 10\text{ A}, V_{GE} = 5\text{ V}$	-	24	-	nC

Table 6. Switching on/off

Symbol	Parameter	Test conditions	Min.	Typ.	Max.	Unit
$t_{d(on)}$ $t_r$	Resistive load Turn-on delay time Rise time	$V_{CC} = 14\text{ V}$ , $R_g = 1\text{ k}\Omega$ , $R_L = 1\ \Omega$ , $V_{GE} = 5\text{ V}$	-	0.7 4	-	$\mu\text{s}$ $\mu\text{s}$
$t_{d(on)}$ $t_r$	Resistive load Turn-on delay time Rise time	$V_{CC} = 14\text{ V}$ , $R_g = 1\text{ k}\Omega$ , $R_L = 1\ \Omega$ , $V_{GE} = 5\text{ V}$ , $T_J = 150\text{ }^\circ\text{C}$	-	0.7 4.5	-	$\mu\text{s}$ $\mu\text{s}$
$t_{d(off)}$ $t_f$ dv/dt	Inductive load Turn-off delay time Fall time Turn-off voltage slope	$V_{CC} = 300\text{ V}$ , $L = 1\text{ mH}$ $I_C = 10\text{ A}$ , $V_{GE} = 5\text{ V}$ , $R_g = 1\text{ k}\Omega$ ,	-	4.3 1.5 165	-	$\mu\text{s}$ $\mu\text{s}$ V/ $\mu\text{s}$
$t_{d(off)}$ $t_f$ dv/dt	Inductive load Turn-off delay time Fall time Turn-off voltage slope	$V_{CC} = 300\text{ V}$ , $L = 1\text{ mH}$ $I_C = 10\text{ A}$ , $V_{GE} = 5\text{ V}$ , $R_g = 1\text{ k}\Omega$ , $T_J = 150\text{ }^\circ\text{C}$	-	4.7 3.5 115	-	$\mu\text{s}$ $\mu\text{s}$ V/ $\mu\text{s}$

## 2.1 Electrical characteristics (curves)

**Figure 2. Collector-emitter on voltage vs temperature ( $V_{ge} = 4.5\text{ V}$ )**

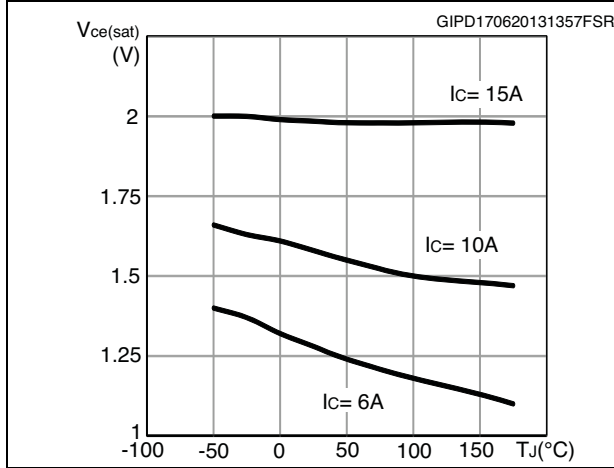

**Figure 3. Collector-emitter on voltage vs temperature ( $I_c = 6\text{ A}$ )**

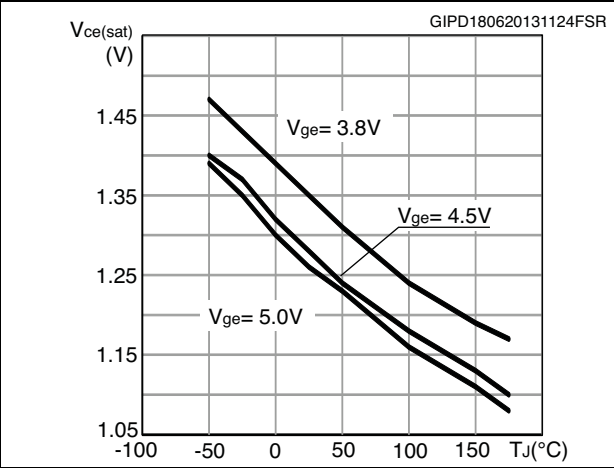

**Figure 4. Collector-emitter on voltage vs temperature ( $I_c = 10\text{ A}$ )**

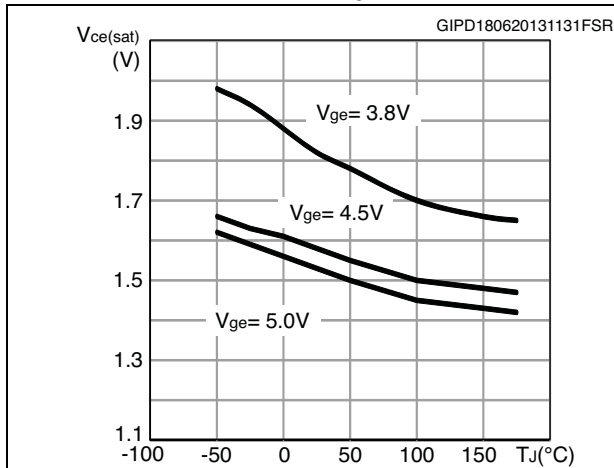

**Figure 5. Self clamped inductive switch**

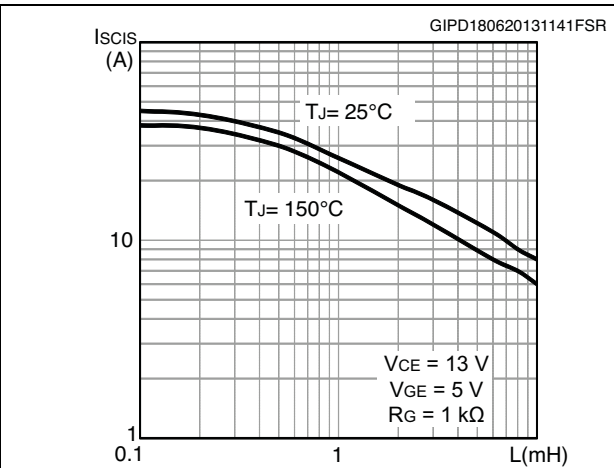

Figure 6. Output characteristics ( $T_J = 25\text{ }^\circ\text{C}$ )

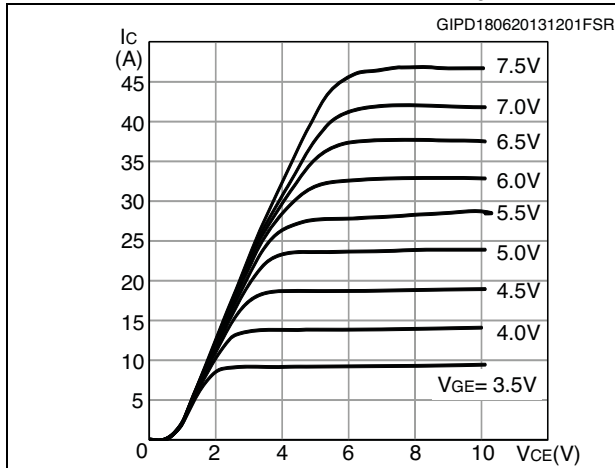

Figure 7. Output characteristics ( $T_J = -40\text{ }^\circ\text{C}$ )

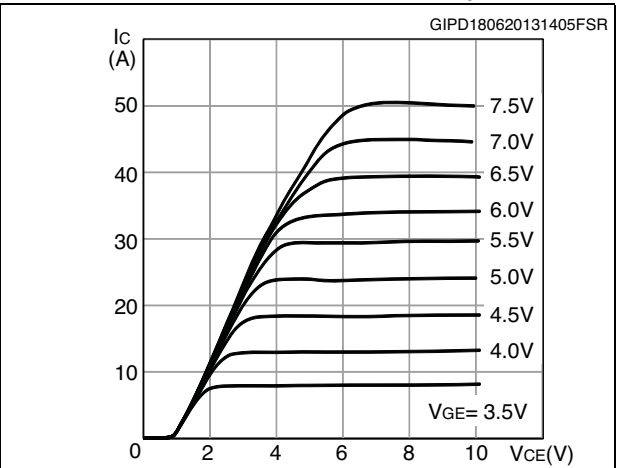

Figure 8. Output characteristics ( $T_J = 175\text{ }^\circ\text{C}$ )

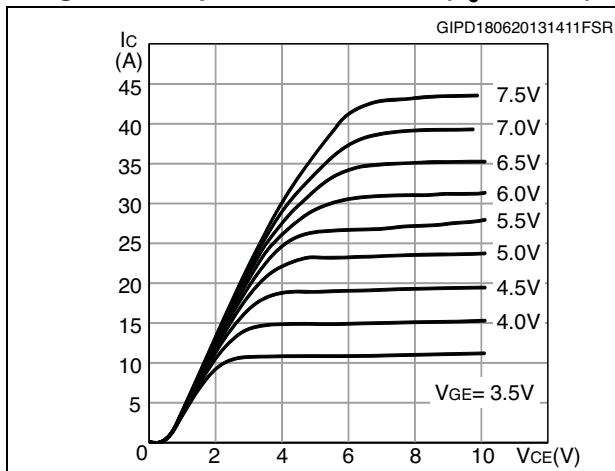

Figure 9. Transfer characteristics

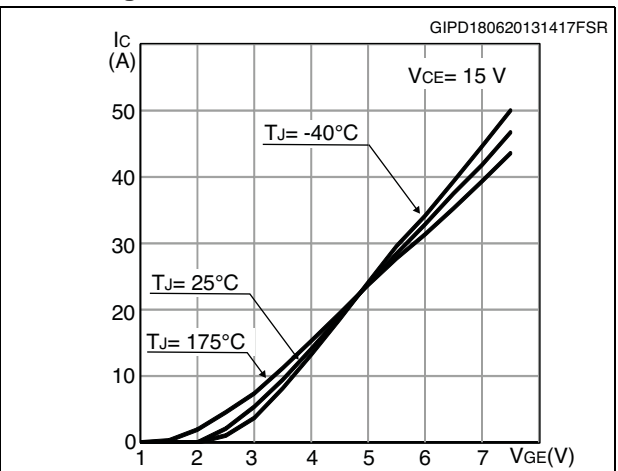

Figure 10. Collector cut-off current vs. temperature

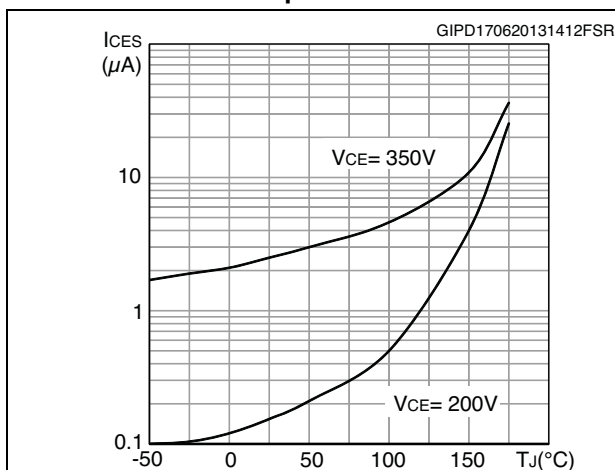

Figure 11. Normalized collector emitter voltage vs temperature

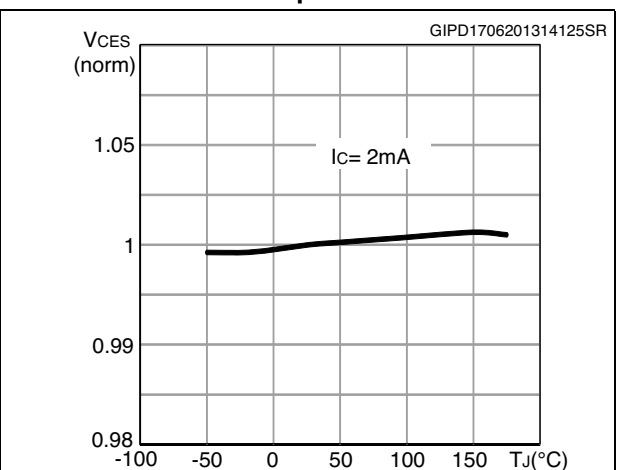

Figure 12. Normalized gate threshold voltage vs temperature

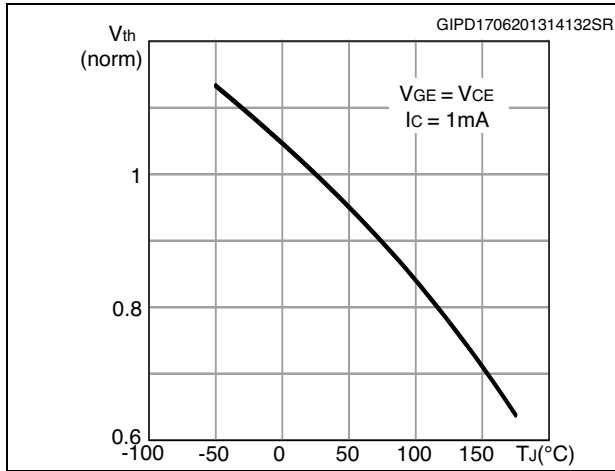

Figure 13. Normalized collector emitter on-voltage vs temperature

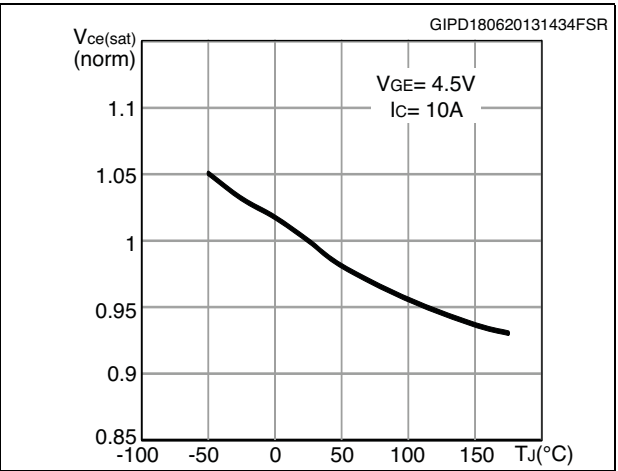

Figure 14. Thermal impedance for D<sup>2</sup>PAK

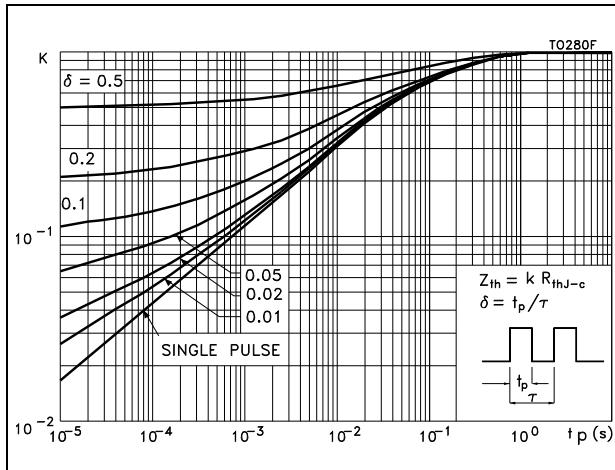
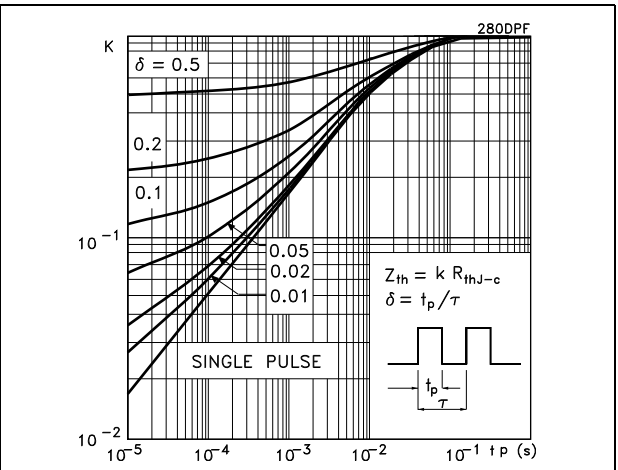

Figure 15. Thermal impedance for DPAK





### 3 Test circuits

Figure 16. Inductive load switching and  $E_{SCIS}$  test circuit

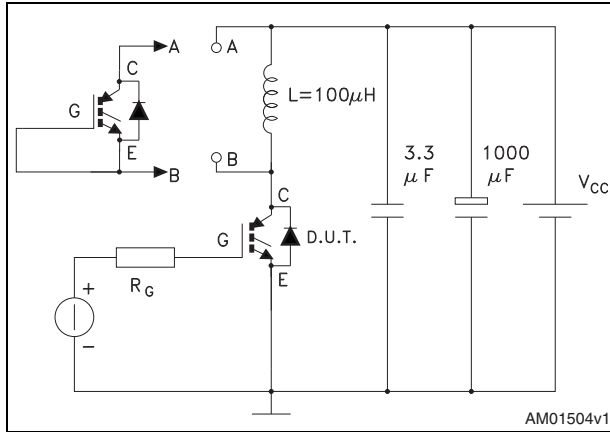

Figure 17. Resistive load switching

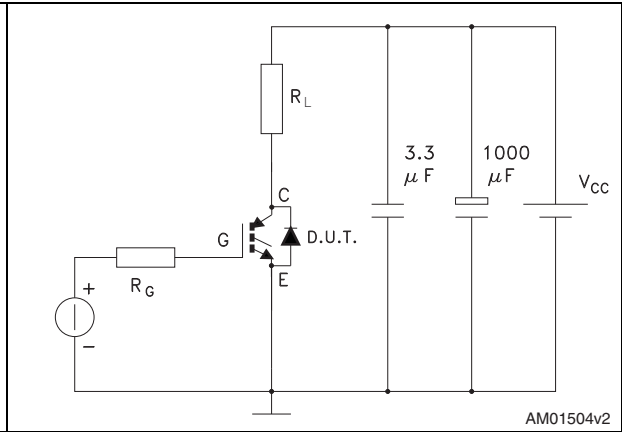

Figure 18. Gate charge test circuit

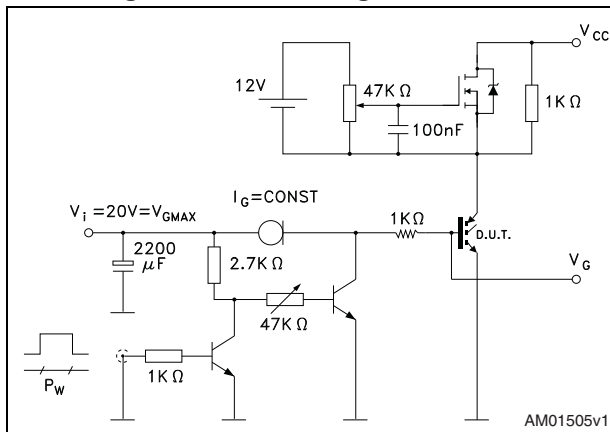
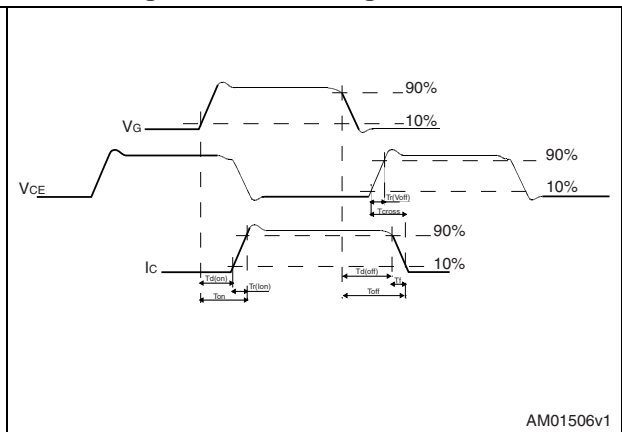

Figure 19. Switching waveform



## 4 Package mechanical data

In order to meet environmental requirements, ST offers these devices in different grades of ECOPACK® packages, depending on their level of environmental compliance. ECOPACK® specifications, grade definitions and product status are available at: [www.st.com](http://www.st.com). ECOPACK® is an ST trademark.

Figure 20. D<sup>2</sup>PAK (TO-263) drawing

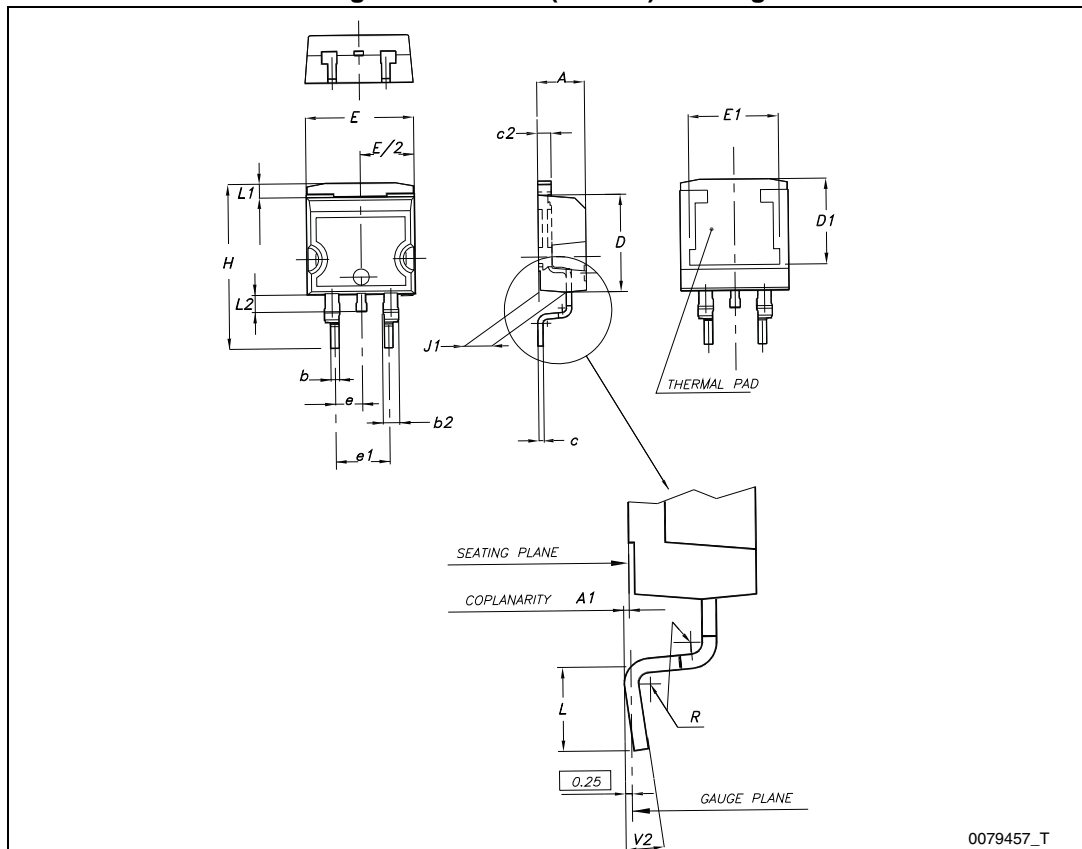
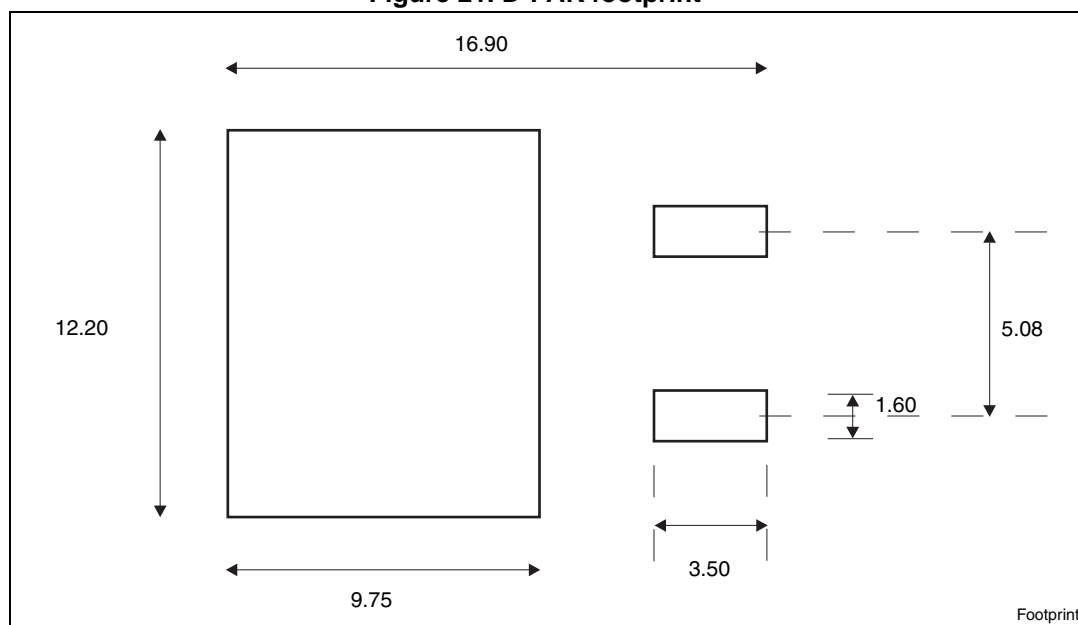

Table 7. D<sup>2</sup>PAK (TO-263) mechanical data

Dim.	mm		
	Min.	Typ.	Max.
A	4.40		4.60
A1	0.03		0.23
b	0.70		0.93
b2	1.14		1.70
c	0.45		0.60
c2	1.23		1.36
D	8.95		9.35
D1	7.50		
E	10		10.40
E1	8.50		
e		2.54	
e1	4.88		5.28
H	15		15.85
J1	2.49		2.69
L	2.29		2.79
L1	1.27		1.40
L2	1.30		1.75
R		0.4	
V2	0°		8°

Figure 21. D<sup>2</sup>PAK footprint<sup>(a)</sup>



a. All dimension are in millimeters

Figure 22. DPAK (TO-252) type A drawing

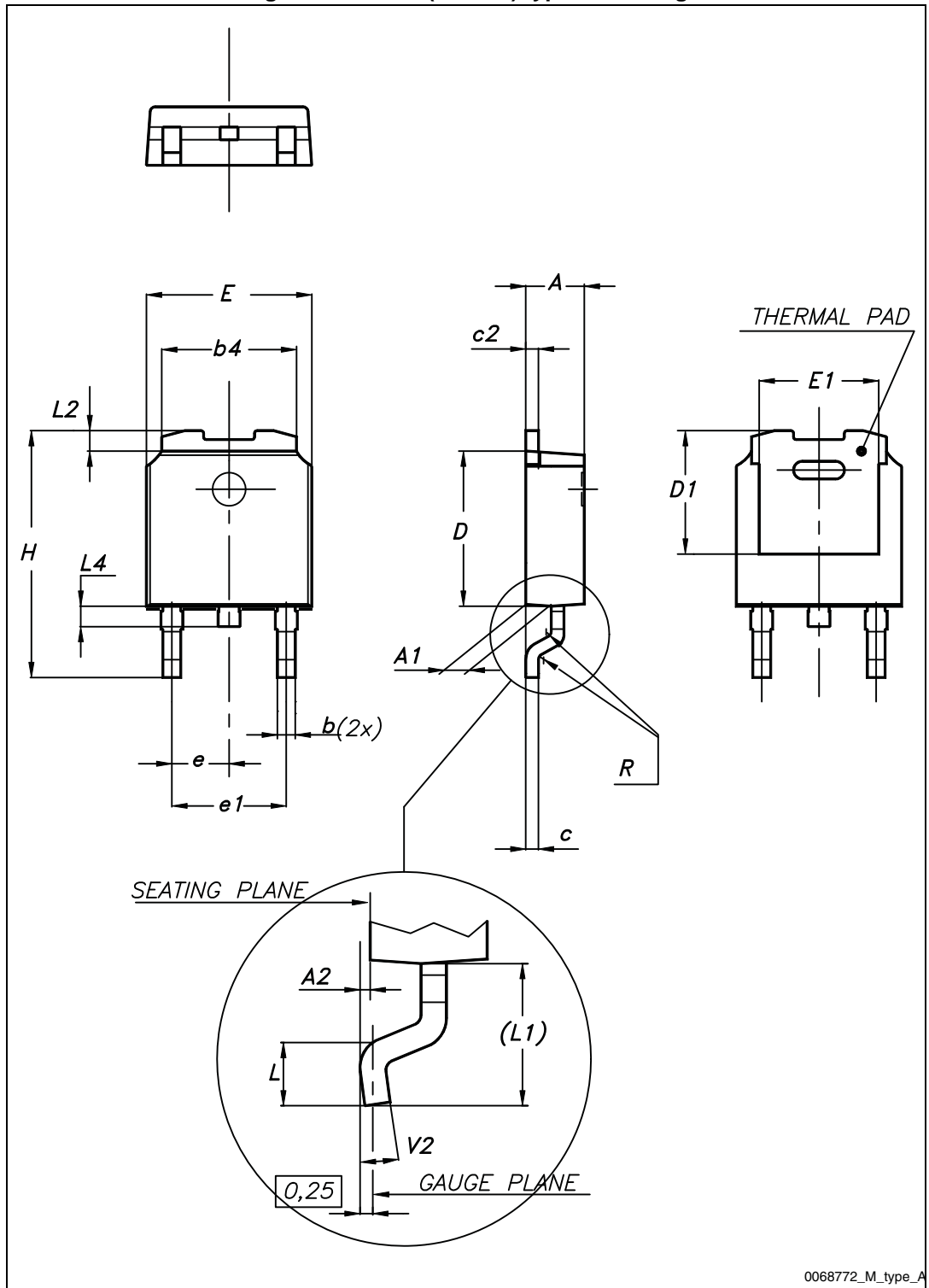
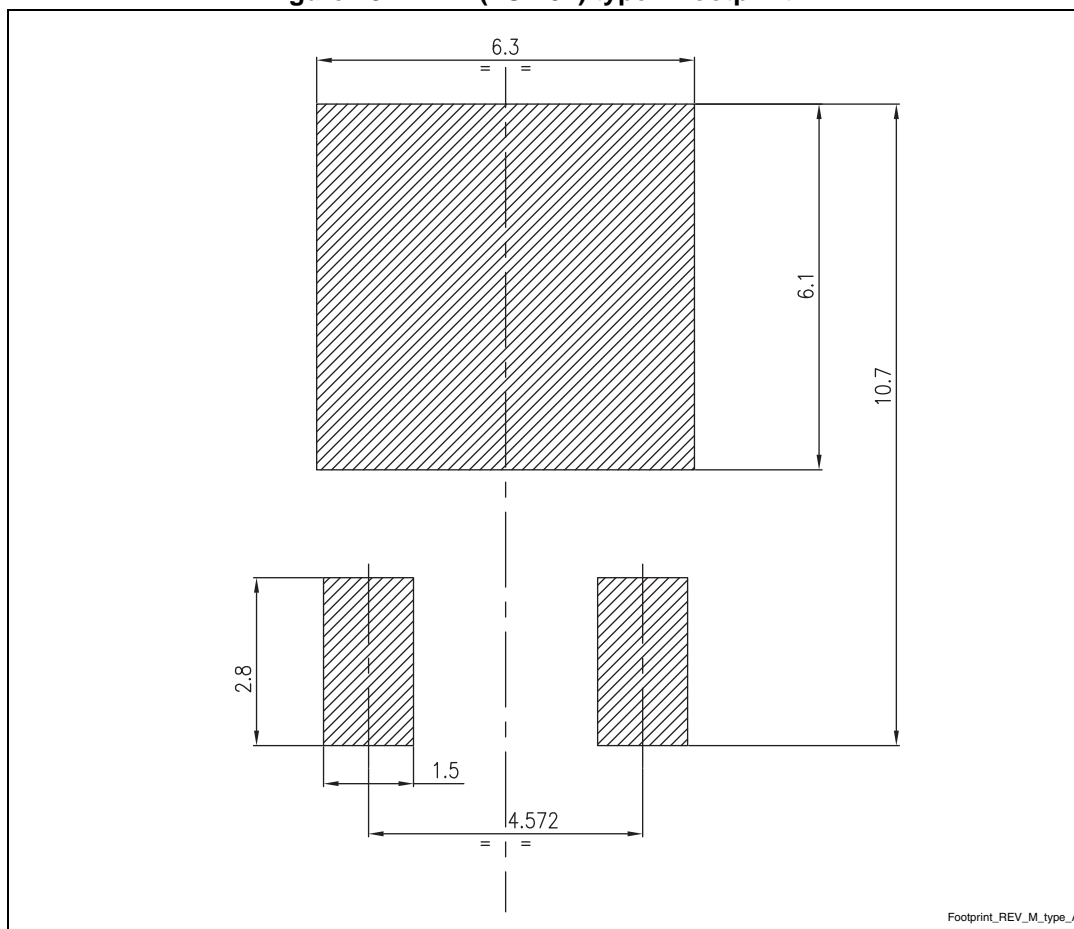

Table 8. DPAK (TO-252) type A mechanical data

Dim.	mm		
	Min.	Typ.	Max.
A	2.20		2.40
A1	0.90		1.10
A2	0.03		0.23
b	0.64		0.90
b4	5.20		5.40
c	0.45		0.60
c2	0.48		0.60
D	6.00		6.20
D1		5.10	
E	6.40		6.60
E1		4.70	
e		2.28	
e1	4.40		4.60
H	9.35		10.10
L	1.00		1.50
(L1)		2.80	
L2		0.80	
L4	0.60		1.00
R		0.20	
V2	0°		8°

Figure 23. DPAK (TO-252) type A footprint (b)



b. All dimensions are in millimeters

# 5 Packaging mechanical data

Figure 24. Tape drawing

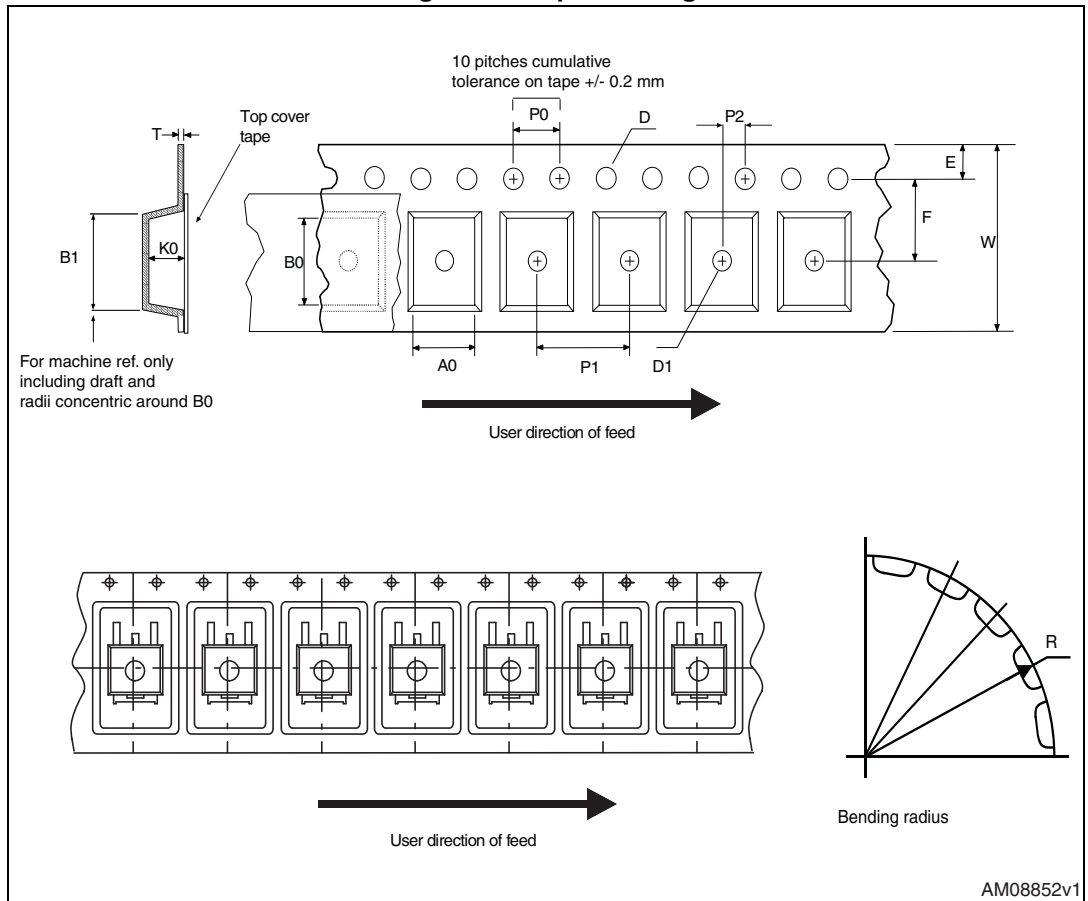



Figure 25. Reel drawing

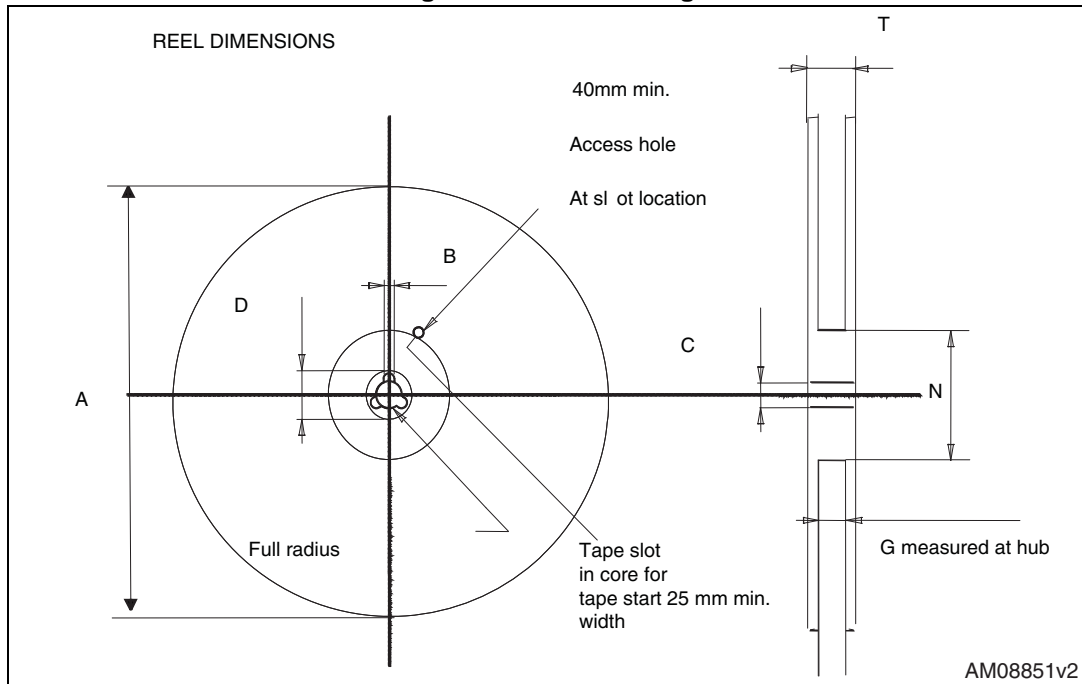

Table 9. D<sup>2</sup>PAK (TO-263) tape and reel mechanical data

Tape			Reel		
Dim.	mm		Dim.	mm	
	Min.	Max.		Min.	Max.
A0	10.5	10.7	A		330
B0	15.7	15.9	B	1.5	
D	1.5	1.6	C	12.8	13.2
D1	1.59	1.61	D	20.2	
E	1.65	1.85	G	24.4	26.4
F	11.4	11.6	N	100	
K0	4.8	5.0	T		30.4
P0	3.9	4.1			
P1	11.9	12.1	Base qty		1000
P2	1.9	2.1	Bulk qty		1000
R	50				
T	0.25	0.35			
W	23.7	24.3			

Table 10. DPAK (TO-252) tape and reel mechanical data

Tape			Reel		
Dim.	mm		Dim.	mm	
	Min.	Max.		Min.	Max.
A0	6.8	7	A		330
B0	10.4	10.6	B	1.5	
B1		12.1	C	12.8	13.2
D	1.5	1.6	D	20.2	
D1	1.5		G	16.4	18.4
E	1.65	1.85	N	50	
F	7.4	7.6	T		22.4
K0	2.55	2.75			
P0	3.9	4.1	Base qty.		2500
P1	7.9	8.1	Bulk qty.		2500
P2	1.9	2.1			
R	40				
T	0.25	0.35			
W	15.7	16.3			

## 6 Revision history

**Table 11. Document revision history**

Date	Revision	Changes
08-Feb-2013	1	Initial release.
24-Jun-2013	2	Added device in D <sup>2</sup> PAK. Modified <a href="#">Table 1: Device summary</a> . Added <a href="#">Section 2.1: Electrical characteristics (curves)</a> . Updated <a href="#">Section 4: Package mechanical data</a> and <a href="#">Section 5: Packaging mechanical data</a> . Minor text changes.
25-Sep-2013	3	Updated $t_{d(on)}$ value for resistive load in <a href="#">Table 6: Switching on/off</a> . Updated mechanical data for DPAK. Minor text changes.
14-Jan-2014	4	Modified title in cover page. Added: $E_{SCIS}$ in <a href="#">Table 2</a> , $V_{ECS}$ and $g_{fs}$ values in <a href="#">Table 4</a> . Modified minimum value of $V_{GE(clamped)}$ in <a href="#">Table 4</a> Updated <a href="#">Section 4: Package mechanical data</a> Modified order codes in <a href="#">Table 1</a> . Minor text changes.
4-Jun-2014	5	Updated features in cover page.