

N-channel 600 V, 14 A, very fast IGBT

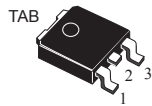

DPAK

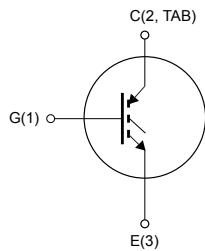

G1C2TE3

Features

Order codes	V_{CES}	$V_{CE(sat)}$ max.	I_C (at $T_C = 100\text{ }^\circ\text{C}$)
STGD7NC60HT4	600 V	2.5 V	14 A

- Low on-voltage drop ($V_{CE(sat)}$)
- High-frequency operation up to 70 kHz

Applications

- Switching applications

Description

This device is a very fast IGBT developed using advanced PowerMESH™ technology. This process guarantees an excellent trade-off between switching performance and low on-state behavior. This device is well-suited for resonant or soft-switching applications.

Product status link

[STGD7NC60HT4](#)

Product summary

Order code	STGD7NC60HT4
Marking	GD7NC60H
Package	DPAK
Packing	Tape and reel

1 Electrical ratings

Table 1. Absolute maximum ratings

Symbol	Parameter	Value	Unit
V_{CES}	Collector-emitter voltage ($V_{GE} = 0$ V)	600	V
I_C	Continuous collector current at $T_C = 25$ °C	25	A
	Continuous collector current at $T_C = 100$ °C	14	A
$I_{CM}^{(1)}$	Pulsed collector current	50	A
V_{GE}	Gate-emitter voltage	±20	V
P_{TOT}	Total dissipation at $T_C = 25$ °C	70	W
T_{STG}	Storage temperature range	-55 to 150	°C
T_J	Operating junction temperature range		

1. Pulse width limited by maximum junction temperature.

Table 2. Thermal data

Symbol	Parameter	Value	Unit
$R_{thJ-case}$	Thermal resistance junction-case	1.78	°C/W
$R_{thJ-amb}$	Thermal resistance junction-ambient	100	°C/W

2 Electrical characteristics

$T_C = 25\text{ °C}$ unless otherwise specified

Table 3. Static characteristics

Symbol	Parameter	Test conditions	Min.	Typ.	Max.	Unit
$V_{(BR)CES}$	Collector-emitter breakdown voltage	$V_{GE} = 0\text{ V}$, $I_C = 1\text{ mA}$	600			V
$V_{CE(sat)}$	Collector-emitter saturation voltage	$V_{GE} = 15\text{ V}$, $I_C = 7\text{ A}$		1.85	2.5	V
		$V_{GE} = 15\text{ V}$, $I_C = 7\text{ A}$, $T_J = 125\text{ °C}$		1.7		
$V_{GE(th)}$	Gate threshold voltage	$V_{CE} = V_{GE}$, $I_C = 250\text{ }\mu\text{A}$	3.75		5.75	V
I_{CES}	Collector cut-off current	$V_{GE} = 0\text{ V}$, $V_{CE} = 600\text{ V}$			10	μA
		$V_{GE} = 0\text{ V}$, $V_{CE} = 600\text{ V}$, $T_C = 125\text{ °C}$ ⁽¹⁾			1	mA
I_{GES}	Gate-emitter leakage current	$V_{CE} = 0\text{ V}$, $V_{GE} = \pm 20\text{ V}$			± 100	nA

1. Defined by design, not subject to production test.

Table 4. Dynamic characteristics

Symbol	Parameter	Test conditions	Min.	Typ.	Max.	Unit
C_{ies}	Input capacitance	$V_{CE} = 25\text{ V}$, $f = 1\text{ MHz}$, $V_{GE} = 0\text{ V}$		720	-	pF
C_{oes}	Output capacitance			81	-	
C_{res}	Reverse transfer capacitance			17	-	
Q_g	Total gate charge	$V_{CE} = 390\text{ V}$, $I_C = 7\text{ A}$, $V_{GE} = 15\text{ V}$ (see Figure 16. Gate charge test circuit)		35	-	nC
Q_{ge}	Gate-emitter charge			7	-	
Q_{gc}	Gate-collector charge			16	-	
I_{CL}	Turn-off SOA minimum current	$V_{clamp} = 480\text{ V}$, $T_J = 150\text{ °C}$, $R_G = 10\text{ }\Omega$, $V_{GE} = 15\text{ V}$	50		-	A

Table 5. Switching characteristics (inductive load)

Symbol	Parameter	Test conditions	Min.	Typ.	Max.	Unit
$t_{d(on)}$	Turn-on delay time	$V_{CC} = 390\text{ V}$, $I_C = 7\text{ A}$, $V_{GE} = 15\text{ V}$, $R_G = 10\ \Omega$ (see Figure 14. I_C vs frequency and Figure 15. Test circuit for inductive load switching)	-	18.5		ns
$t_{r(on)}$	Turn-on rise time		-	8.5		ns
$di/dt_{(on)}$	Turn-on current slope		-	1060		A/ μ s
$t_{r(off)}$	Turn-off rise time		-	27		ns
$t_{d(off)}$	Turn-off delay time		-	72		ns
t_f	Fall time		-	60		ns
$E_{on}^{(1)}$	Turn-on switching energy		-	95	125	μ J
$E_{off}^{(2)}$	Turn-off switching energy		-	115	150	μ J
E_{ts}	Total switching energy		-	210	275	μ J
$t_{d(on)}$	Turn-on delay time		$V_{CE} = 390\text{ V}$, $I_C = 7\text{ A}$, $V_{GE} = 15\text{ V}$, $R_G = 10\ \Omega$, $T_J = 125\text{ }^\circ\text{C}$ (see Figure 14. I_C vs frequency and Figure 15. Test circuit for inductive load switching)	-	18.5	
$t_{r(on)}$	Turn-on rise time	-		7		ns
$di/dt_{(on)}$	Turn-on current slope	-		1000		A/ μ s
$t_{r(off)}$	Turn-off rise time	-		56		ns
$t_{d(off)}$	Turn-off delay time	-		116		ns
t_f	Fall time	-		105		ns
$E_{on}^{(1)}$	Turn-on switching energy	-		140		μ J
$E_{off}^{(2)}$	Turn-off switching energy	-		215		μ J
E_{ts}	Total switching energy	-		355		μ J

1. Including the reverse recovery of the diode. The diode is the same as the co-packaged in STGP7NC60HD.
2. Including the tail of the collector current.

2.1 Electrical characteristics (curves)

Figure 1. Output characteristics

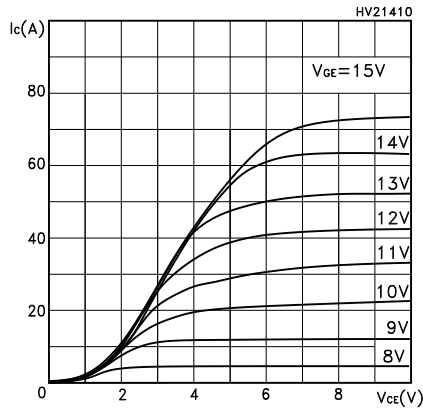

Figure 2. Transfer characteristics

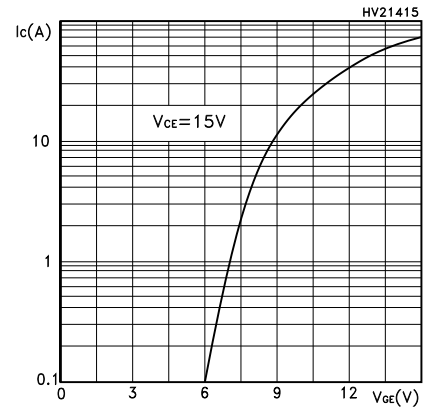

Figure 3. Collector-emitter on voltage vs temperature

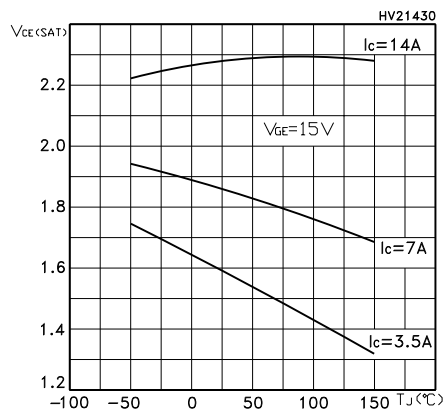

Figure 4. Collector-emitter on voltage vs collector current

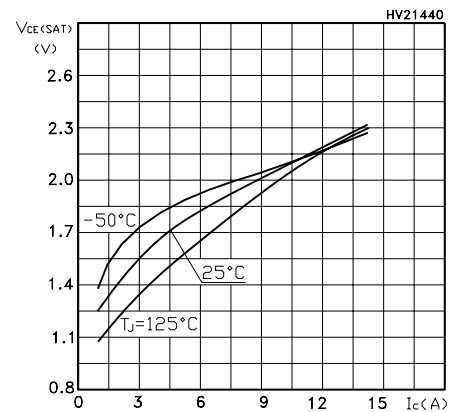

Figure 5. Normalized gate threshold vs temperature

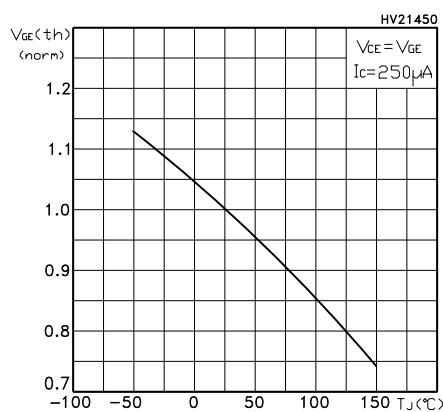

Figure 6. Normalized breakdown voltage vs temperature

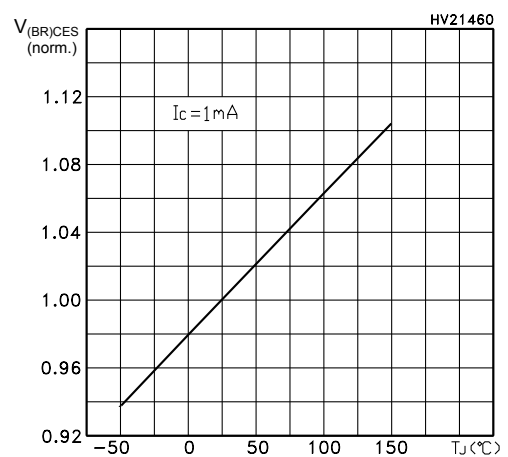

Figure 7. Gate charge vs gate-emitter voltage

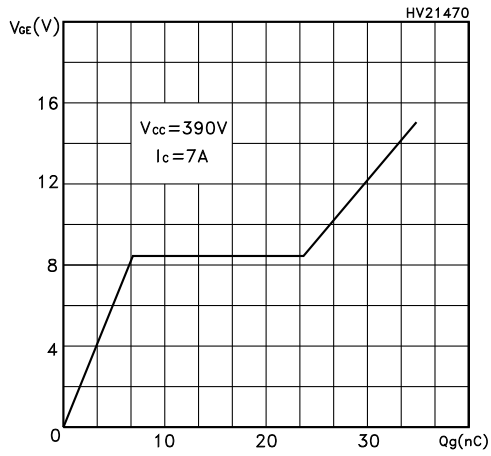

Figure 8. Capacitance variations

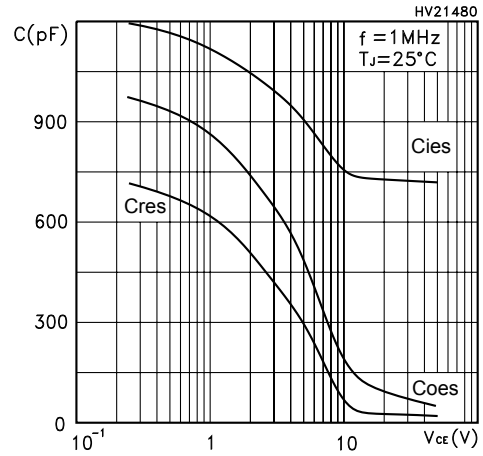

Figure 9. Total switching energy vs temperature

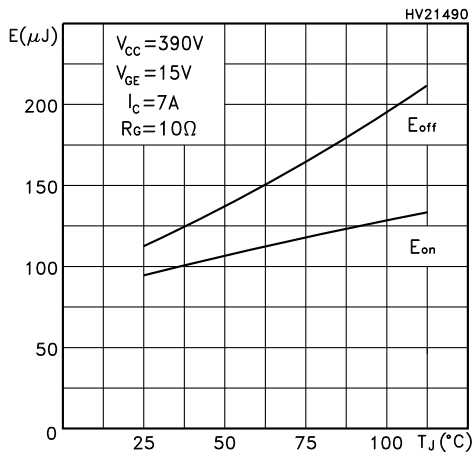

Figure 10. Total switching energy vs gate resistance

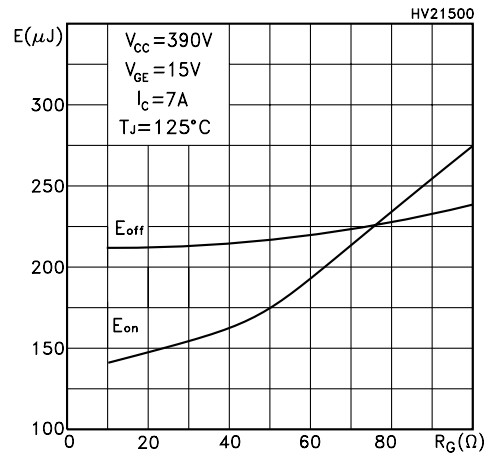

Figure 11. Total switching energy vs collector current

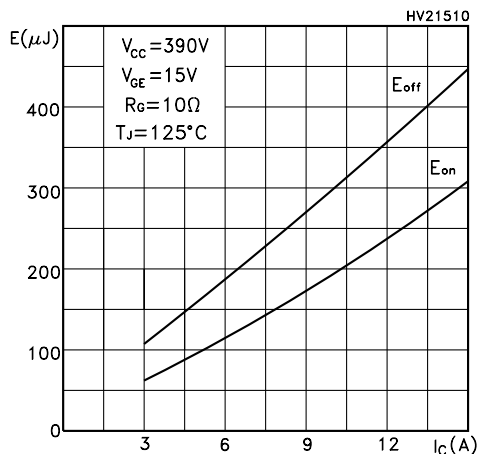

Figure 12. Thermal impedance

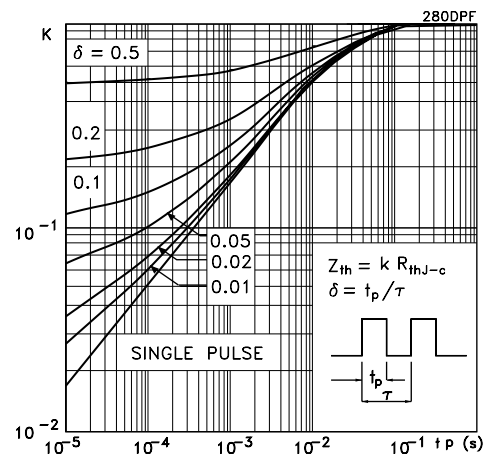

Figure 13. Turn-off SOA

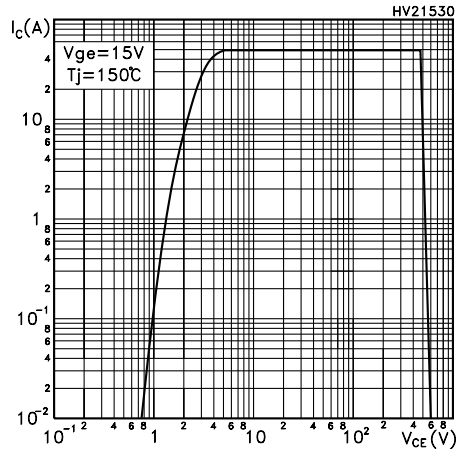
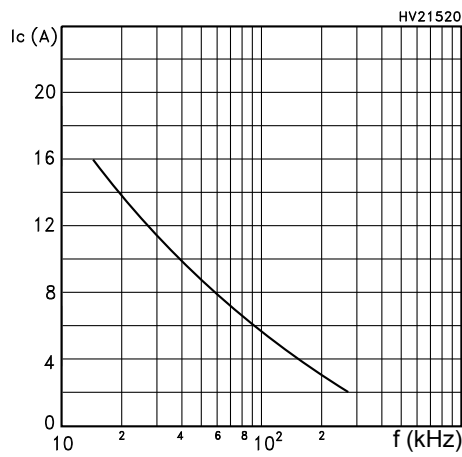
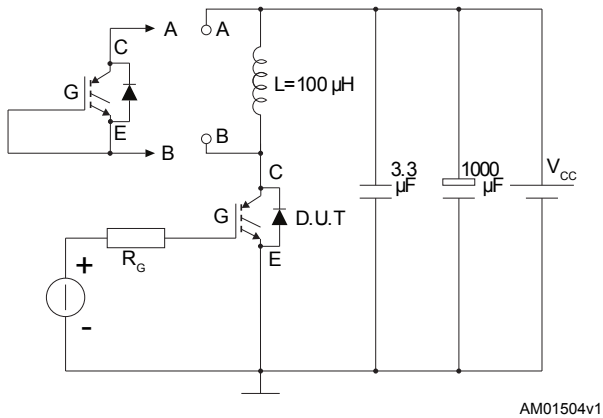
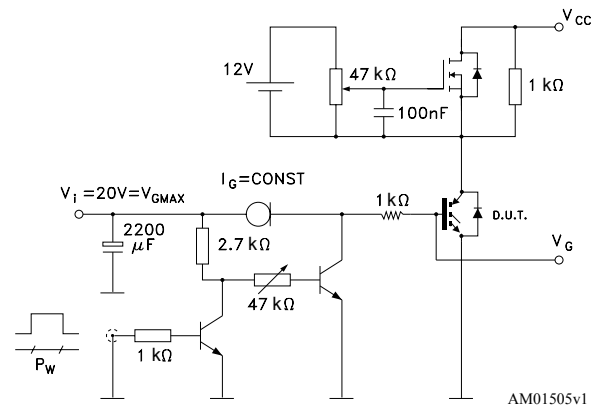
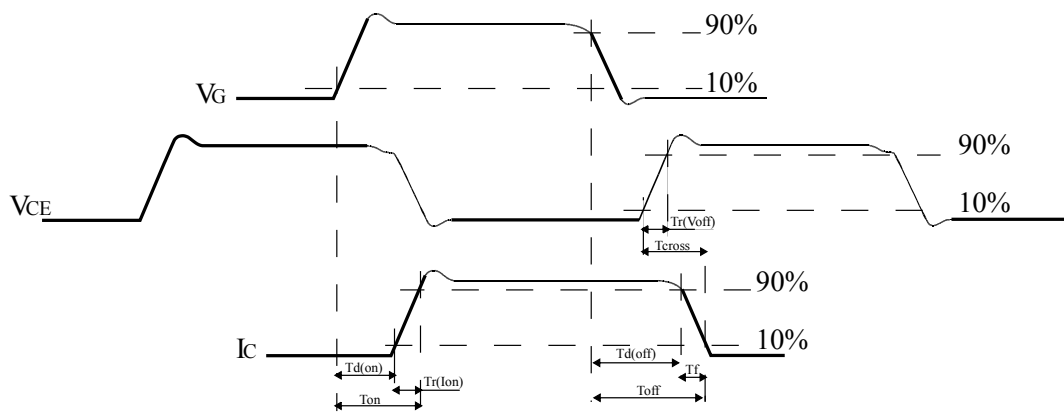

Figure 14. I_c vs frequency



3 Test circuits

Figure 15. Test circuit for inductive load switching

Figure 16. Gate charge test circuit

Figure 17. Switching waveform

4 Package information

In order to meet environmental requirements, ST offers these devices in different grades of ECOPACK® packages, depending on their level of environmental compliance. ECOPACK® specifications, grade definitions and product status are available at: www.st.com. ECOPACK® is an ST trademark.

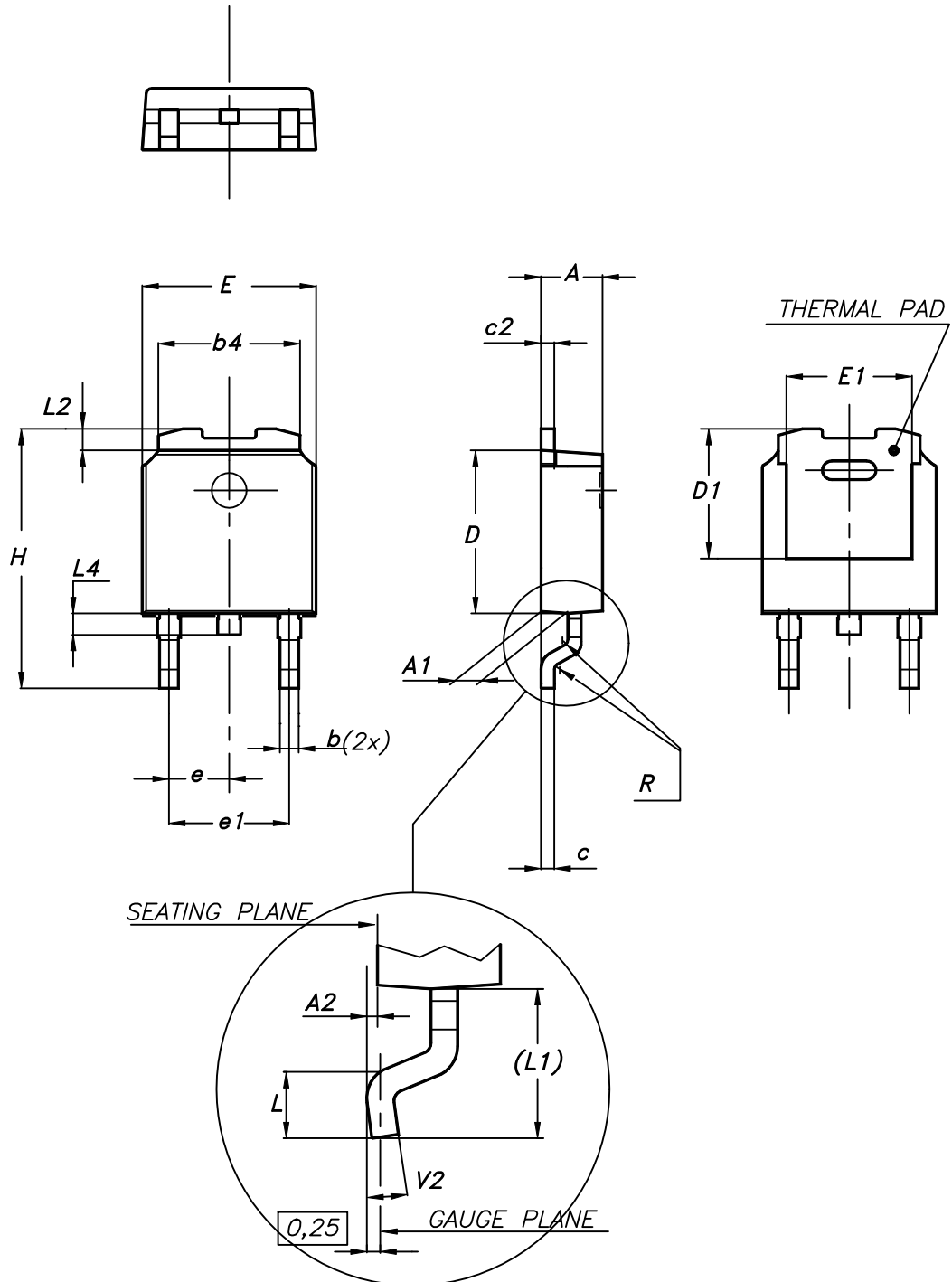
4.1 DPAK (TO-252) type A2 package information

Figure 18. DPAK (TO-252) type A2 package outline



0068772_type-A2_rev25

Table 6. DPAK (TO-252) type A2 mechanical data

Dim.	mm		
	Min.	Typ.	Max.
A	2.20		2.40
A1	0.90		1.10
A2	0.03		0.23
b	0.64		0.90
b4	5.20		5.40
c	0.45		0.60
c2	0.48		0.60
D	6.00		6.20
D1	4.95	5.10	5.25
E	6.40		6.60
E1	5.10	5.20	5.30
e	2.159	2.286	2.413
e1	4.445	4.572	4.699
H	9.35		10.10
L	1.00		1.50
L1	2.60	2.80	3.00
L2	0.65	0.80	0.95
L4	0.60		1.00
R		0.20	
V2	0°		8°

4.2 DPAK (TO-252) type C2 package information

Figure 19. DPAK (TO-252) type C2 package outline

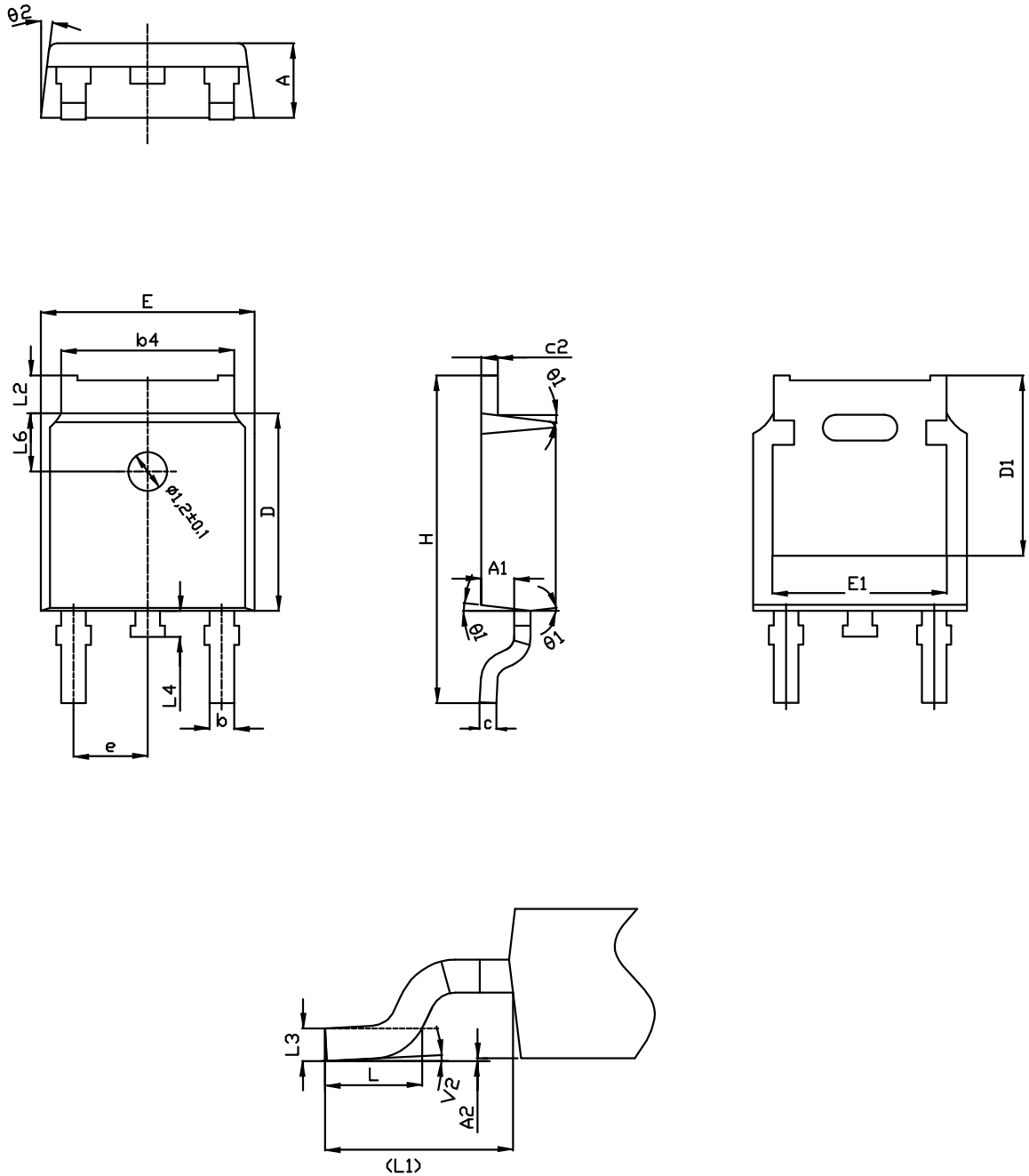

0068772_C2_25

Table 7. DPAK (TO-252) type C2 mechanical data

Dim.	mm		
	Min.	Typ.	Max.
A	2.20	2.30	2.38
A1	0.90	1.01	1.10
A2	0.00		0.10
b	0.72		0.85
b4	5.13	5.33	5.46
c	0.47		0.60
c2	0.47		0.60
D	6.00	6.10	6.20
D1	5.10		5.60
E	6.50	6.60	6.70
E1	5.20		5.50
e	2.186	2.286	2.386
H	9.80	10.10	10.40
L	1.40	1.50	1.70
L1	2.90 REF		
L2	0.90		1.25
L3	0.51 BSC		
L4	0.60	0.80	1.00
L6	1.80 BSC		
θ1	5°	7°	9°
θ2	5°	7°	9°
V2	0°		8°

Figure 20. DPAK (TO-252) recommended footprint (dimensions are in mm)

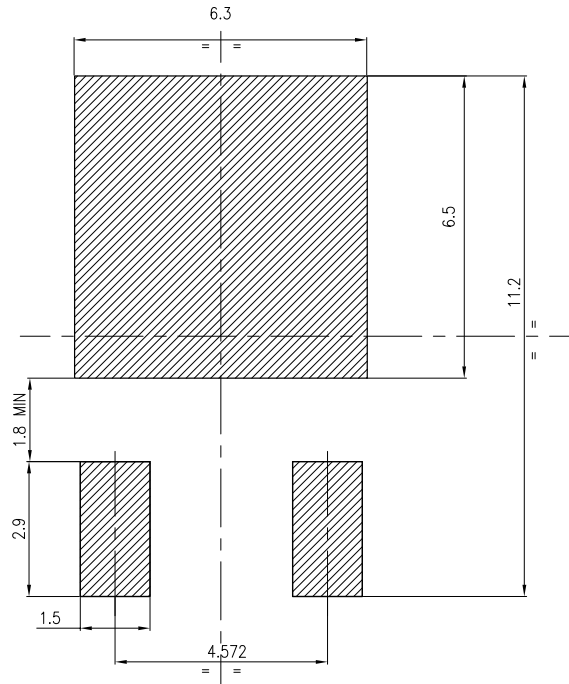

FP_0068772_25

4.3 DPAK (TO-252) packing information

Figure 21. DPAK (TO-252) tape outline

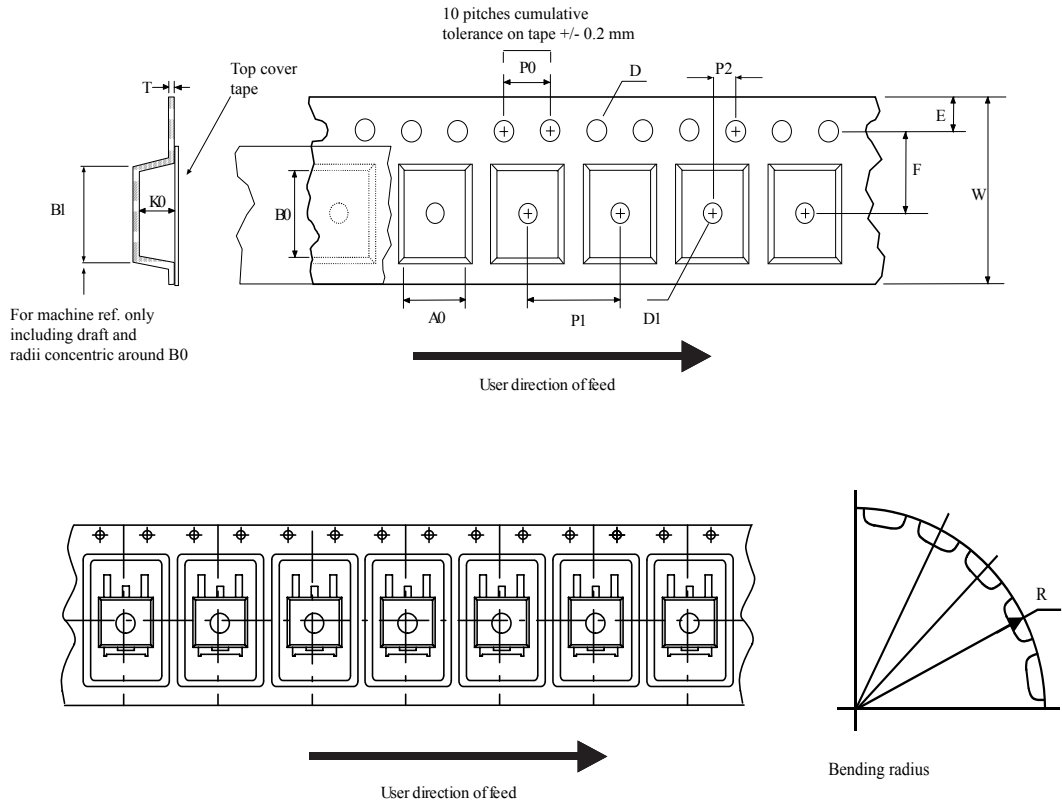

AM08852v1

Figure 22. DPAK (TO-252) reel outline

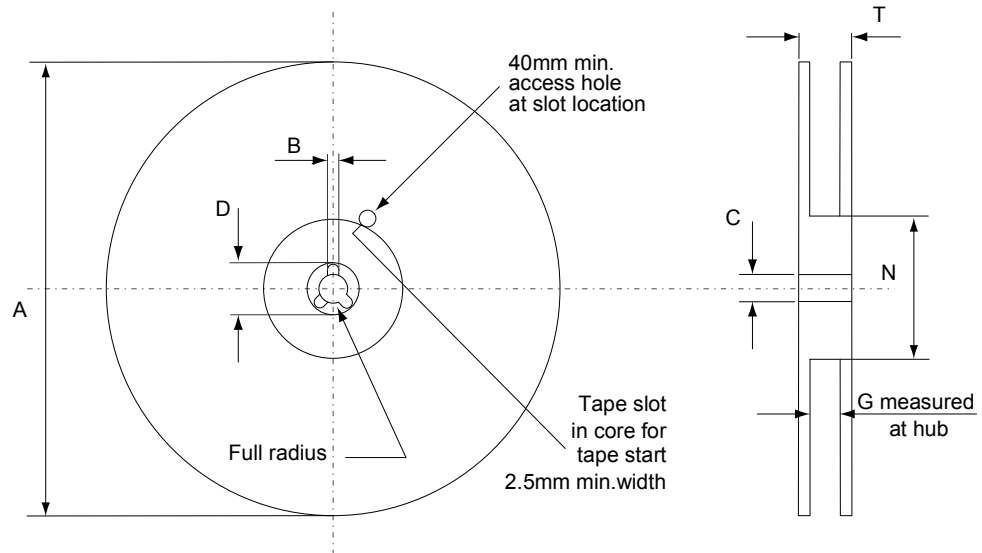

AM06038v1

Table 8. DPAK (TO-252) tape and reel mechanical data

Dim.	Tape		Dim.	Reel	
	mm			mm	
	Min.	Max.		Min.	Max.
A0	6.8	7	A		330
B0	10.4	10.6	B	1.5	
B1		12.1	C	12.8	13.2
D	1.5	1.6	D	20.2	
D1	1.5		G	16.4	18.4
E	1.65	1.85	N	50	
F	7.4	7.6	T		22.4
K0	2.55	2.75			
P0	3.9	4.1	Base qty.		2500
P1	7.9	8.1	Bulk qty.		2500
P2	1.9	2.1			
R	40				
T	0.25	0.35			
W	15.7	16.3			

Revision history

Table 9. Document revision history

Date	Revision	Changes
11-Jul-2016	1	First release. Part number previously included in datasheet DocID10855.
15-Dec-2016	2	Updated Features table on cover page. Minor text changes
02-Oct-2018	3	Removed maturity status indication from cover page. The document status is production data. Updated Section 4 Package information . Minor text changes.

Contents

1	Electrical ratings	2
2	Electrical characteristics	3
2.1	Electrical characteristics (curves)	5
3	Test circuits	8
4	Package information	9
4.1	DPAK (TO-252) type A2 package information	9
4.2	DPAK (TO-252) type C2 package information	11
4.3	DPAK (TO-252) packing information	14
	Revision history	17