

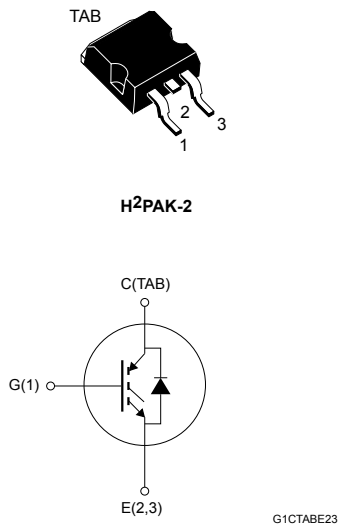

Automotive-grade trench gate field-stop, 650 V, 30 A, high-speed HB series IGBT in an H²PAK-2 package



Features

- AEC-Q101 qualified 
- High-speed switching series
- Maximum junction temperature: $T_J = 175\text{ °C}$
- $V_{CE(sat)} = 1.55\text{ V (typ.) @ } I_C = 30\text{ A}$
- Safer paralleling
- Tight parameter distribution
- Low thermal resistance
- Soft and very fast recovery antiparallel diode

Applications

- DC/DC converter for EV/HEV
- HVAC and climate control

Description

This device is an IGBT developed using an advanced proprietary trench gate field-stop structure. The device is part of the new HB series of IGBTs, which represents an optimum compromise between conduction and switching loss to maximize the efficiency of any frequency converter. Furthermore, the slightly positive $V_{CE(sat)}$ temperature coefficient and very tight parameter distribution result in safer paralleling operation.

Product status link

[STGH30H65DFB-2AG](#)

Product summary

Order code	STGH30H65DFB-2AG
Marking	G30H65DFBAG
Package	H ² PAK-2
Packing	Tape and reel

1 Electrical ratings

Table 1. Absolute maximum ratings

Symbol	Parameter	Value	Unit
V_{CES}	Collector-emitter voltage ($V_{GE} = 0$ V)	650	V
I_C	Continuous collector current at $T_C = 25$ °C	60	A
	Continuous collector current at $T_C = 100$ °C	30	
$I_{CP}^{(1)}$	Pulsed collector current	90	A
V_{GE}	Gate-emitter voltage	± 20	V
	Transient gate-emitter voltage ($t_p \leq 10$ μ s)	± 30	
I_F	Continuous forward current at $T_C = 25$ °C	40	A
	Continuous forward current at $T_C = 100$ °C	20	
$I_{FP}^{(1)}$	Pulsed forward current	60	A
P_{TOT}	Total power dissipation at $T_C = 25$ °C	260	W
T_{STG}	Storage temperature range	-55 to 150	°C
T_J	Operating junction temperature range	-55 to 175	°C

1. Pulse width is limited by maximum junction temperature.

Table 2. Thermal data

Symbol	Parameter	Value	Unit
R_{thJC}	Thermal resistance, junction-to-case IGBT	0.58	°C/W
	Thermal resistance, junction-to-case diode	1.32	
R_{thJA}	Thermal resistance, junction-to-ambient	62.5	°C/W

2 Electrical characteristics

$T_J = 25\text{ °C}$ unless otherwise specified.

Table 3. Static characteristics

Symbol	Parameter	Test conditions	Min.	Typ.	Max.	Unit
$V_{(BR)CES}$	Collector-emitter breakdown voltage	$V_{GE} = 0\text{ V}, I_C = 2\text{ mA}$	650			V
$V_{CE(sat)}$	Collector-emitter saturation voltage	$V_{GE} = 15\text{ V}, I_C = 30\text{ A}$		1.55	2.0	V
		$V_{GE} = 15\text{ V}, I_C = 30\text{ A}, T_J = 125\text{ °C}$		1.65		
		$V_{GE} = 15\text{ V}, I_C = 30\text{ A}, T_J = 175\text{ °C}$		1.75		
V_F	Forward on-voltage	$I_F = 20\text{ A}$		2.0	2.8	V
		$I_F = 20\text{ A}, T_J = 125\text{ °C}$		1.75		
		$I_F = 20\text{ A}, T_J = 175\text{ °C}$		1.65		
$V_{GE(th)}$	Gate threshold voltage	$V_{CE} = V_{GE}, I_C = 1\text{ mA}$	4.5	5.5	6.5	V
I_{CES}	Collector cut-off current	$V_{GE} = 0\text{ V}, V_{CE} = 650\text{ V}$			10	μA
I_{GES}	Gate-emitter leakage current	$V_{CE} = 0\text{ V}, V_{GE} = \pm 20\text{ V}$			± 250	nA

Table 4. Dynamic characteristics

Symbol	Parameter	Test conditions	Min.	Typ.	Max.	Unit
C_{ies}	Input capacitance	$V_{CE} = 25\text{ V}, f = 1\text{ MHz}, V_{GE} = 0\text{ V}$	-	3695	-	pF
C_{oes}	Output capacitance		-	123	-	pF
C_{res}	Reverse transfer capacitance		-	73	-	pF
Q_g	Total gate charge	$V_{CC} = 520\text{ V}, I_C = 30\text{ A}, V_{GE} = 0\text{ to }15\text{ V}$ (see Figure 28. Gate charge test circuit)	-	155	-	nC
Q_{ge}	Gate-emitter charge		-	24	-	nC
Q_{gc}	Gate-collector charge		-	63	-	nC

Table 5. Switching characteristics (inductive load)

Symbol	Parameter	Test conditions	Min.	Typ.	Max.	Unit
$t_{d(on)}$	Turn-on delay time	$V_{CC} = 400\text{ V}$, $I_C = 30\text{ A}$, $V_{GE} = 15\text{ V}$, $R_G = 10\ \Omega$ (see Figure 27. Test circuit for inductive load switching)	-	24	-	ns
t_r	Current rise time		-	20	-	ns
$di/dt_{(on)}$	Turn-on current slope		-	1100	-	A/ μ s
$E_{on}^{(1)}$	Turn-on switching energy		-	555	-	μ J
$t_{d(off)}$	Turn-off delay time		-	170	-	ns
t_f	Current fall time		-	16	-	ns
$E_{off}^{(2)}$	Turn-off switching energy		-	300	-	μ J
E_{ts}	Total switching energy		-	855	-	μ J
$t_{d(on)}$	Turn-on delay time		$V_{CC} = 400\text{ V}$, $I_C = 30\text{ A}$, $V_{GE} = 15\text{ V}$, $R_G = 10\ \Omega$, $T_J = 175\text{ }^\circ\text{C}$ (see Figure 27. Test circuit for inductive load switching)	-	23	-
t_r	Current rise time	-		18	-	ns
$di/dt_{(on)}$	Turn-on current slope	-		1135	-	A/ μ s
$E_{on}^{(1)}$	Turn-on switching energy	-		950	-	μ J
$t_{d(off)}$	Turn-off delay time	-		188	-	ns
t_f	Current fall time	-		56	-	ns
$E_{off}^{(2)}$	Turn-off switching energy	-		500	-	μ J
E_{ts}	Total switching energy	-		1450	-	μ J

1. Including the reverse recovery of the diode.

2. Including the tail of the collector current.

Table 6. Diode switching characteristics (inductive load)

Symbol	Parameter	Test conditions	Min.	Typ.	Max.	Unit
t_{rr}	Reverse recovery time	$I_F = 20\text{ A}$, $V_R = 400\text{ V}$, $V_{GE} = 15\text{ V}$, $di/dt = 1000\text{ A}/\mu\text{s}$ (see Figure 30. Diode reverse recovery waveform)	-	28	-	ns
Q_{rr}	Reverse recovery charge		-	189	-	nC
I_{rrm}	Reverse recovery current		-	11.8	-	A
E_{rr}	Reverse recovery energy		-	78	-	μ J
t_{rr}	Reverse recovery time	$I_F = 20\text{ A}$, $V_R = 400\text{ V}$, $V_{GE} = 15\text{ V}$, $di/dt = 1000\text{ A}/\mu\text{s}$, $T_J = 175\text{ }^\circ\text{C}$ (see Figure 30. Diode reverse recovery waveform)	-	139	-	ns
Q_{rr}	Reverse recovery charge		-	1160	-	nC
I_{rrm}	Reverse recovery current		-	16.8	-	A
E_{rr}	Reverse recovery energy		-	167	-	μ J

2.1 Electrical characteristics (curves)

Figure 1. Total power dissipation vs case temperature

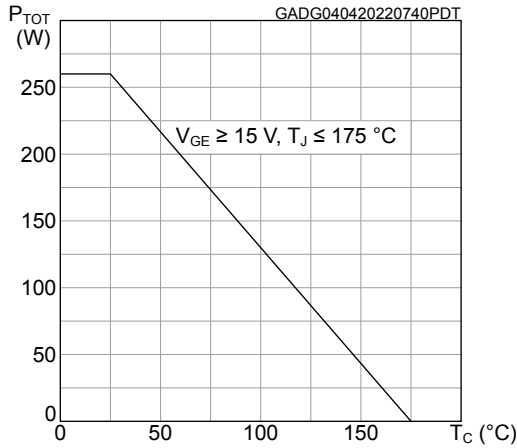

Figure 2. Collector current vs case temperature

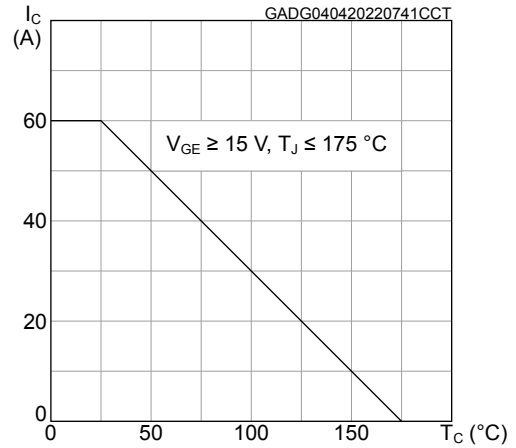

Figure 3. Output characteristics ($T_J = 25^\circ\text{C}$)

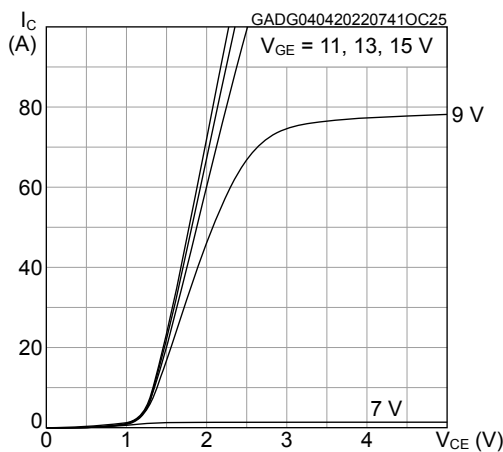

Figure 4. Output characteristics ($T_J = 175^\circ\text{C}$)

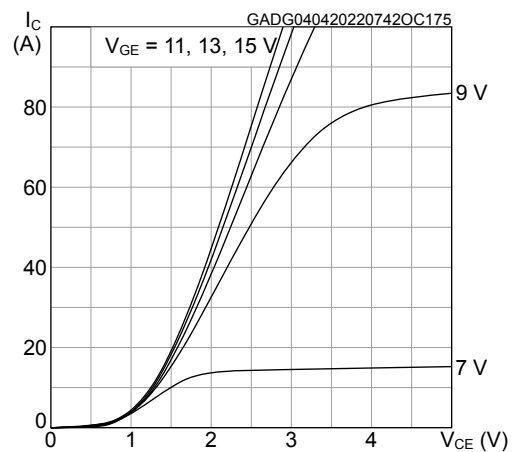

Figure 5. $V_{CE(sat)}$ vs junction temperature

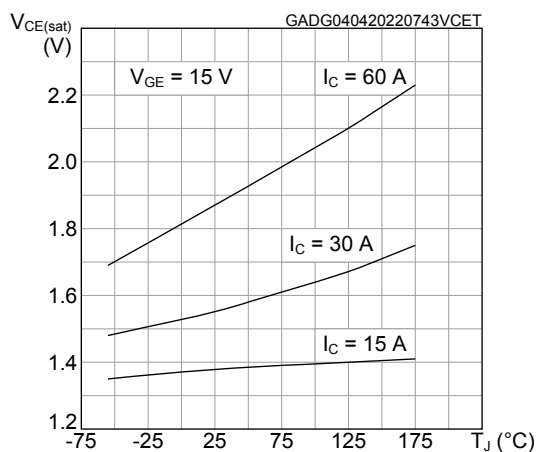

Figure 6. $V_{CE(sat)}$ vs collector current

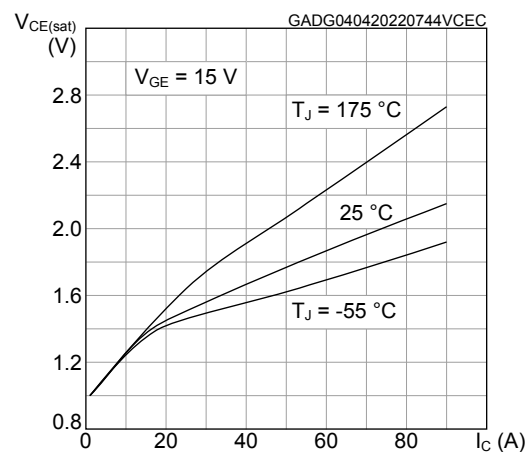

Figure 7. Forward bias safe operating area

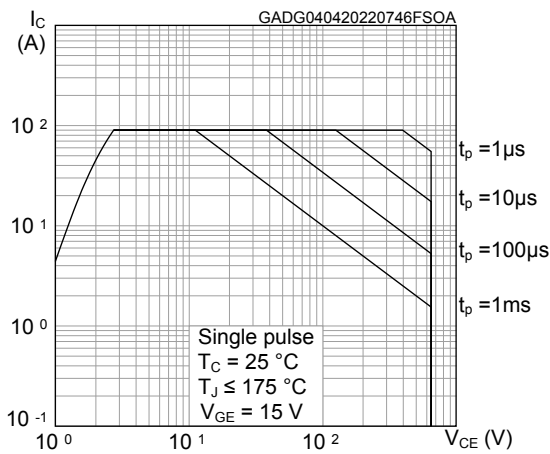

Figure 8. Collector current vs switching frequency

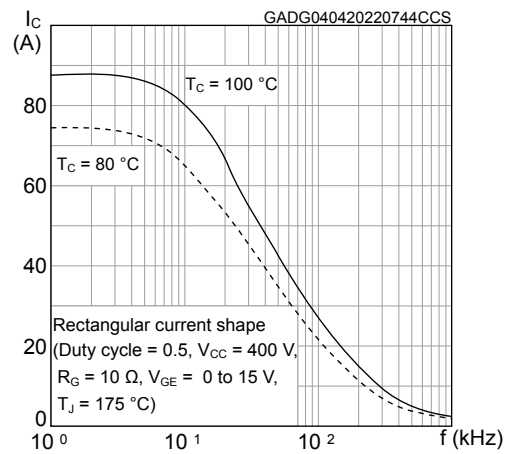

Figure 9. Transfer characteristics

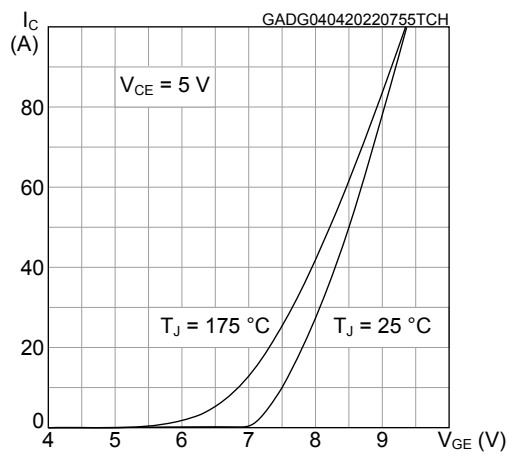

Figure 10. Diode V_F vs forward current

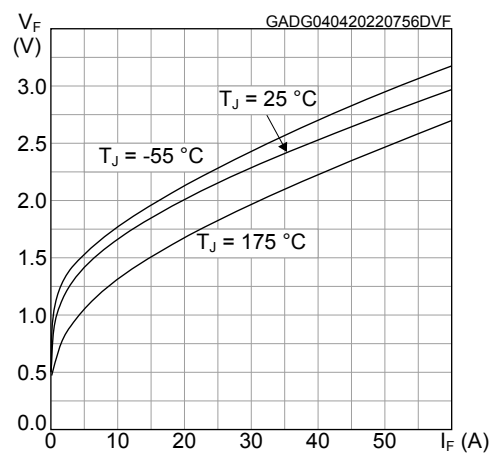

Figure 11. Normalized V_GE(th) vs junction temperature

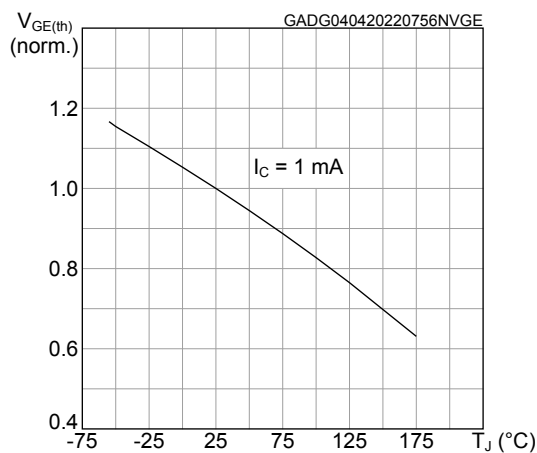

Figure 12. Normalized V_(BR)CES vs junction temperature

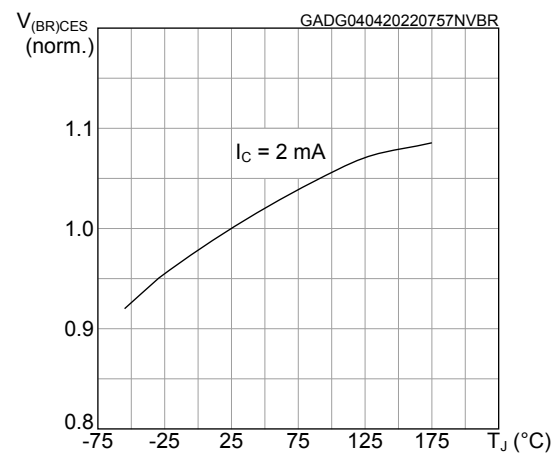

Figure 13. Capacitance variations

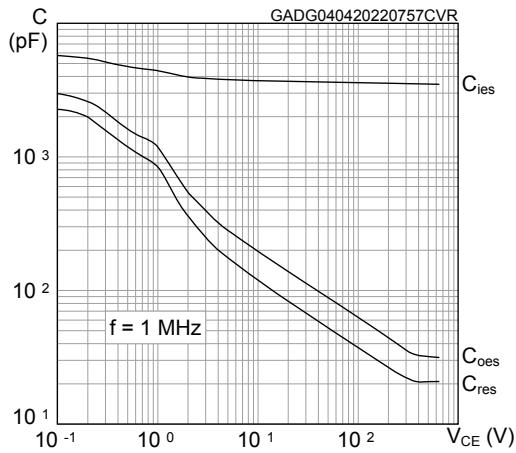

Figure 14. Gate charge vs gate-emitter voltage

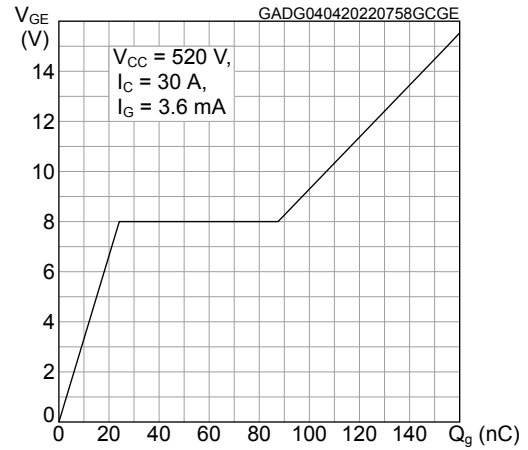

Figure 15. Switching energy vs collector current

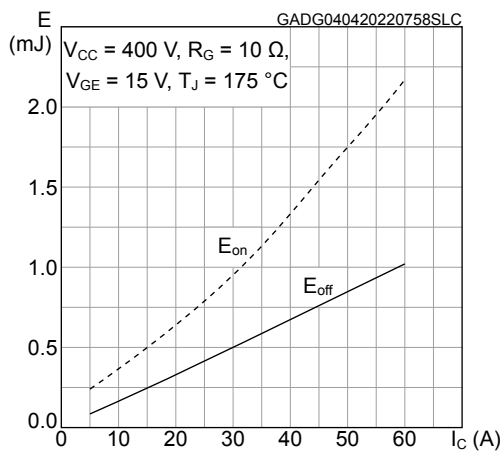

Figure 16. Switching energy vs temperature

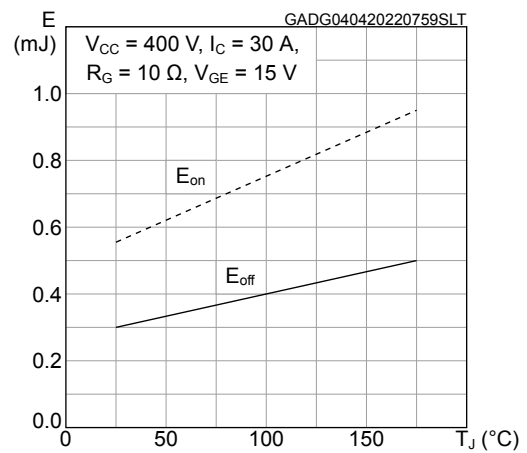

Figure 17. Switching energy vs collector emitter voltage

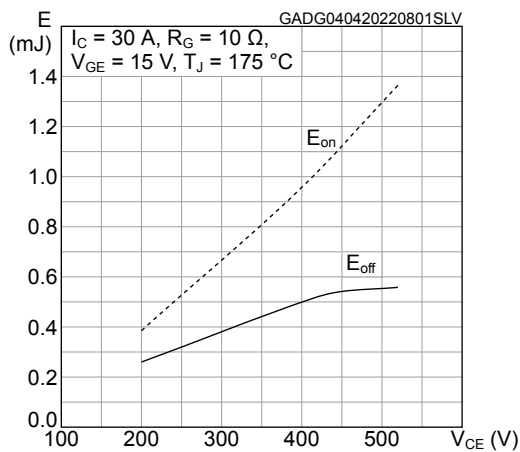

Figure 18. Switching energy vs gate resistance

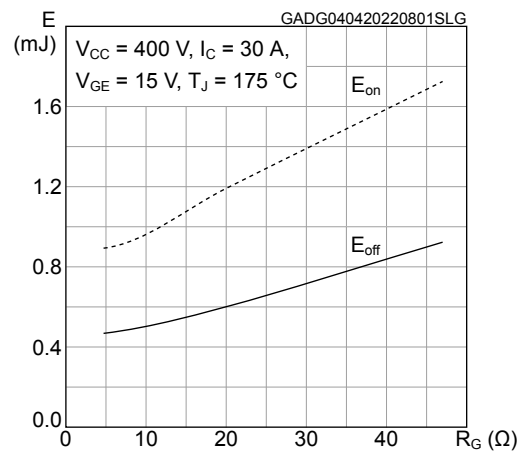

Figure 19. Switching times vs collector current

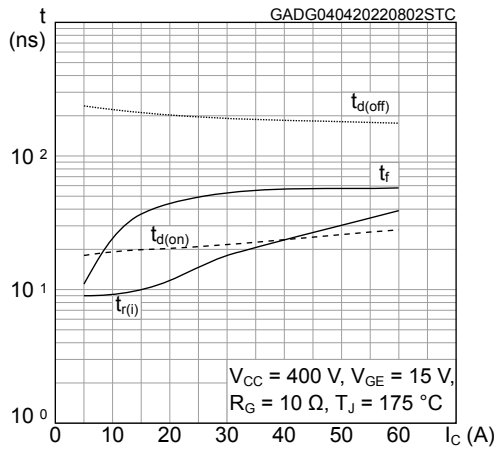

Figure 20. Switching times vs gate resistance

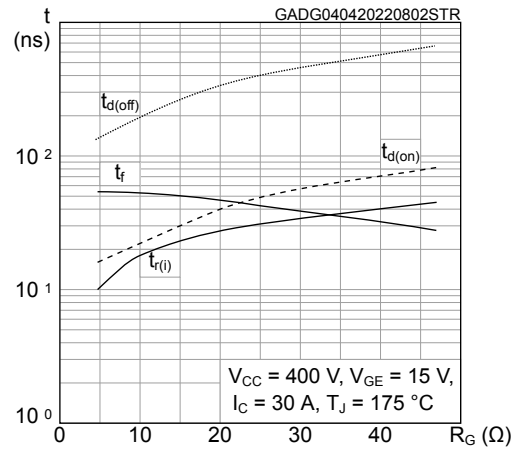

Figure 21. Reverse recovery current vs diode current slope

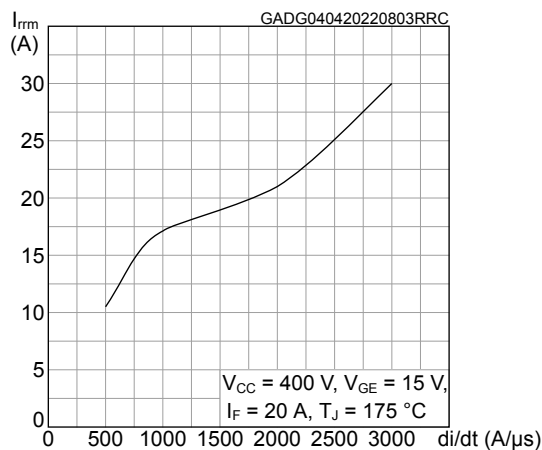

Figure 22. Reverse recovery time vs diode current slope

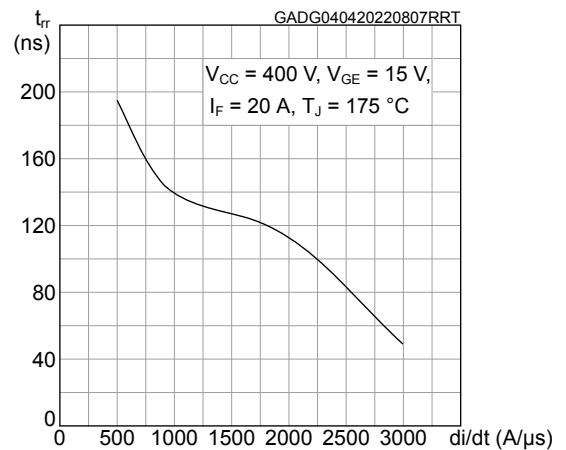

Figure 23. Reverse recovery charge vs diode current slope

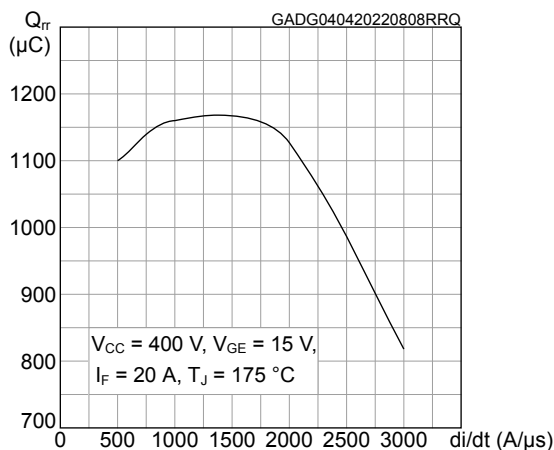

Figure 24. Reverse recovery energy vs diode current slope

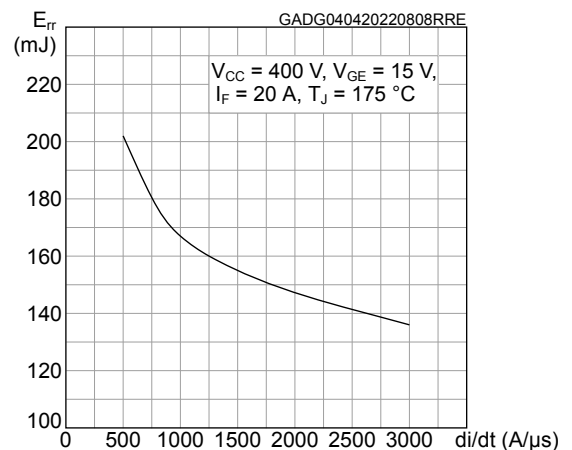

Figure 25. Maximum transient thermal impedance for IGBT

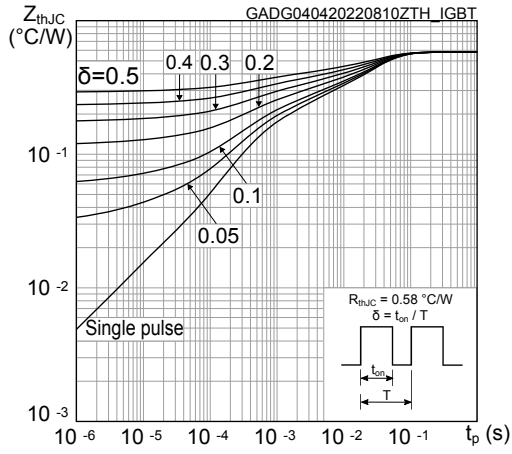
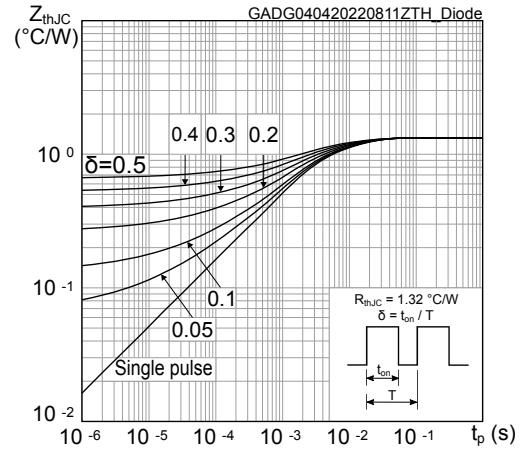
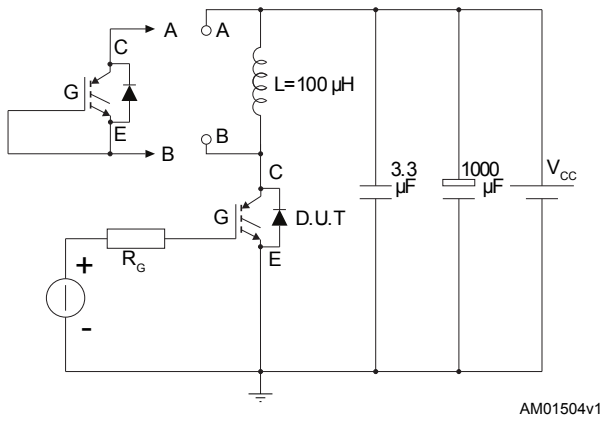
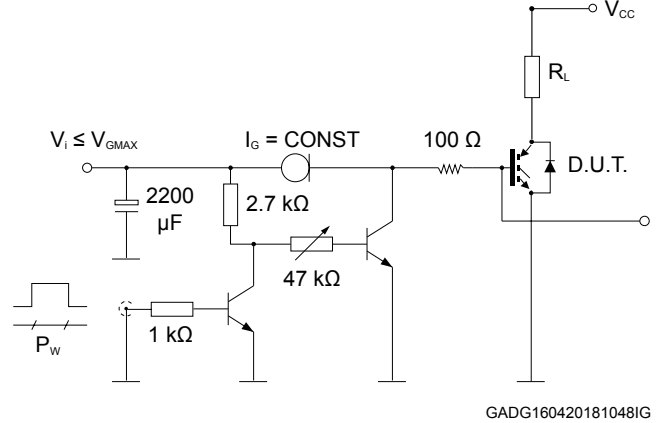
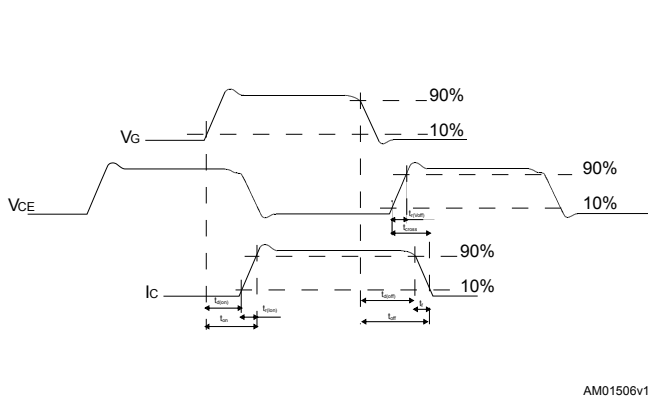
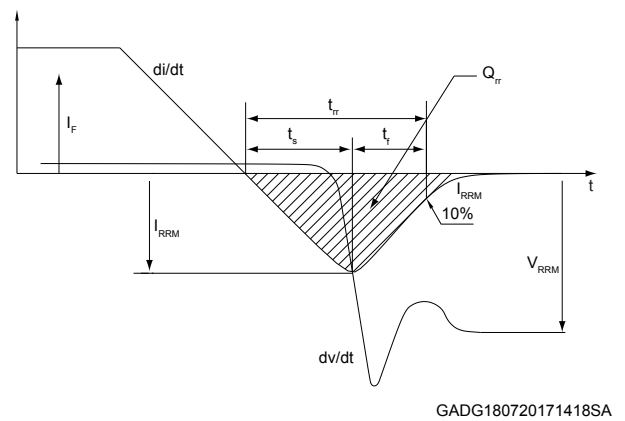

Figure 26. Maximum transient thermal impedance for diode



3 Test circuits

Figure 27. Test circuit for inductive load switching

Figure 28. Gate charge test circuit

Figure 29. Switching waveform

Figure 30. Diode reverse recovery waveform

4 Package information

In order to meet environmental requirements, ST offers these devices in different grades of **ECOPACK** packages, depending on their level of environmental compliance. ECOPACK specifications, grade definitions and product status are available at: www.st.com. ECOPACK is an ST trademark.

4.1 H²PAK-2 package information

Figure 31. H²PAK-2 package outline

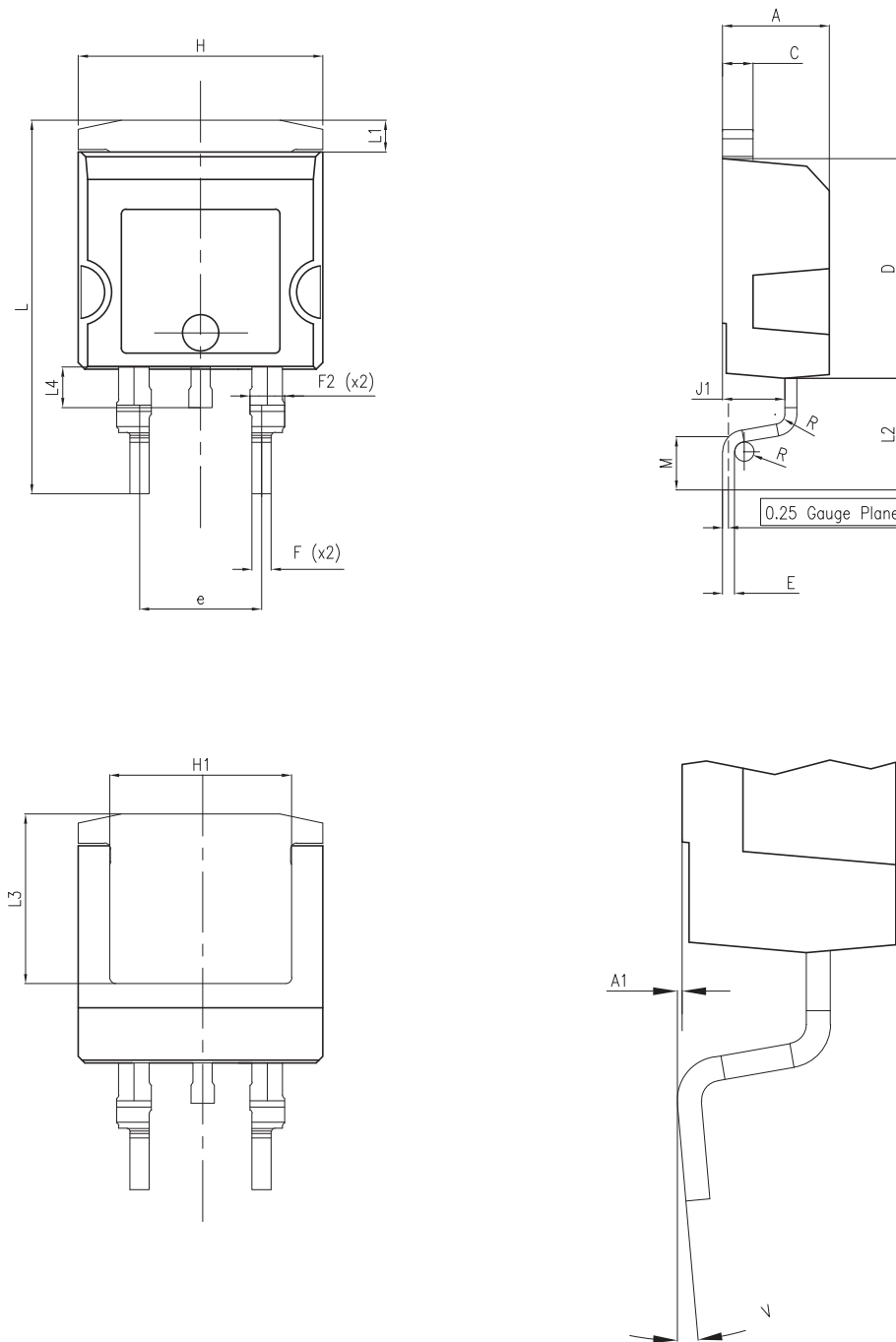
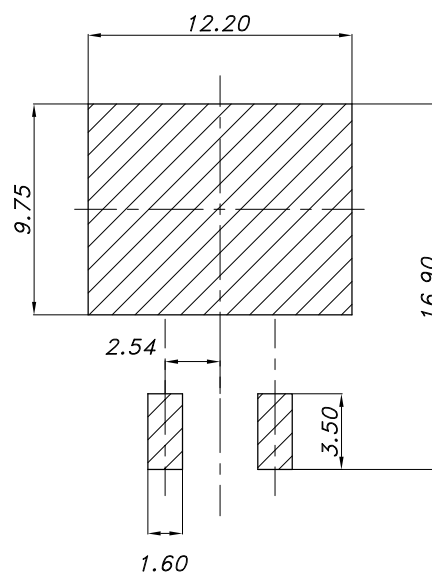

Table 7. H²PAK-2 package mechanical data

Dim.	mm		
	Min.	Typ.	Max.
A	4.30		4.70
A1	0.03		0.20
C	1.17		1.37
D	8.95		9.35
e	4.98		5.18
E	0.50		0.90
F	0.78		0.85
F2	1.14		1.70
H	10.00		10.40
H1	7.40	-	7.80
J1	2.49		2.69
L	15.30		15.80
L1	1.27		1.40
L2	4.93		5.23
L3	6.85		7.25
L4	1.50		1.70
M	2.60		2.90
R	0.20		0.60
V	0°		8°

Figure 32. H²PAK-2 recommended footprint



8159712_10

Note: Dimensions are in mm.

4.2 Packing information

Figure 33. Tape outline

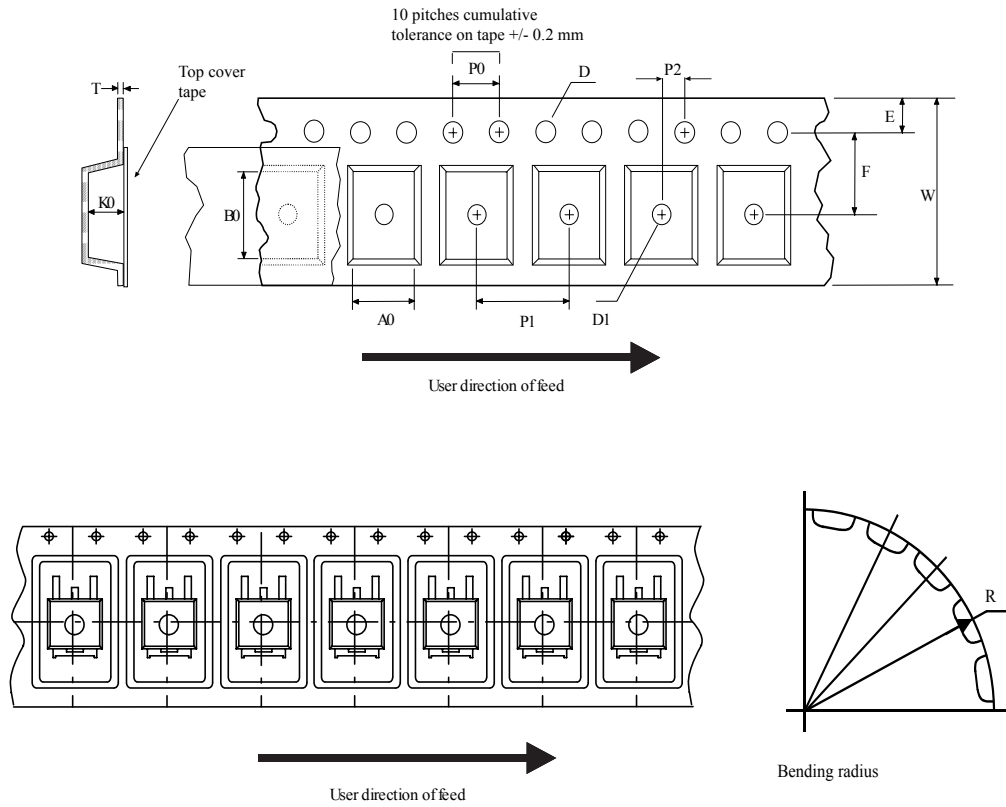

AM08852v2

Figure 34. Reel outline

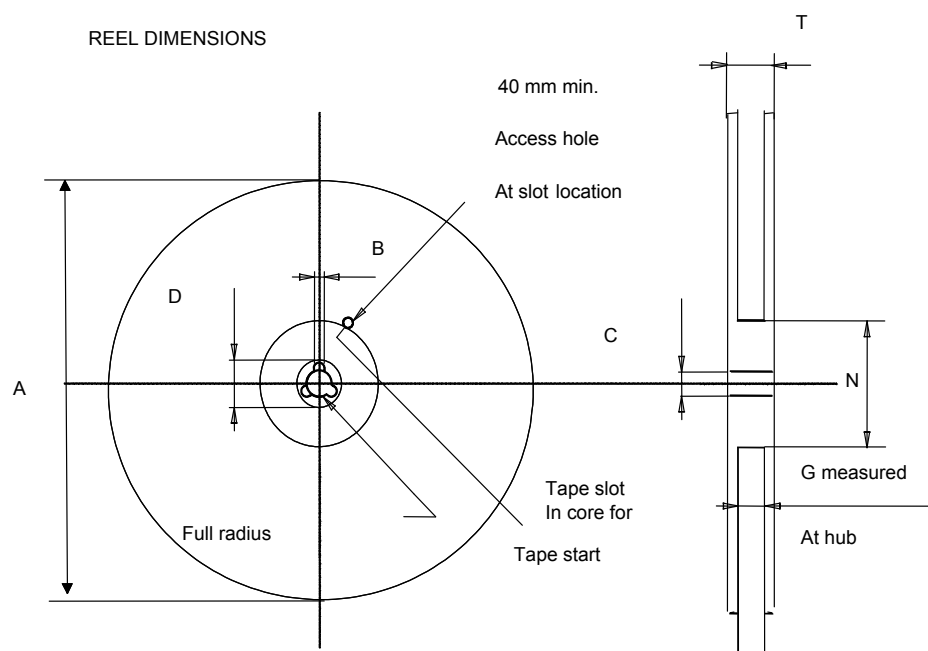

Table 8. Tape and reel mechanical data

Tape			Reel		
Dim.	mm		Dim.	mm	
	Min.	Max.		Min.	Max.
A0	10.5	10.7	A		330
B0	15.7	15.9	B	1.5	
D	1.5	1.6	C	12.8	13.2
D1	1.59	1.61	D	20.2	
E	1.65	1.85	G	24.4	26.4
F	11.4	11.6	N	100	
K0	4.8	5.0	T		30.4
P0	3.9	4.1			
P1	11.9	12.1	Base quantity		1000
P2	1.9	2.1	Bulk quantity		1000
R	50				
T	0.25	0.35			
W	23.7	24.3			

Revision history

Table 9. Document revision history

Date	Revision	Changes
05-Apr-2022	1	First release.
13-Apr-2022	2	Updated Table 3. Static characteristics and Table 4. Dynamic characteristics. Updated Figure 12. Normalized $V_{(BR)CES}$ vs junction temperature.

Contents

1	Electrical ratings	2
2	Electrical characteristics	3
2.1	Electrical characteristics (curves)	5
3	Test circuits	10
4	Package information	11
4.1	H ² PAK-2 package information	11
4.2	Packing information	13
	Revision history	15