

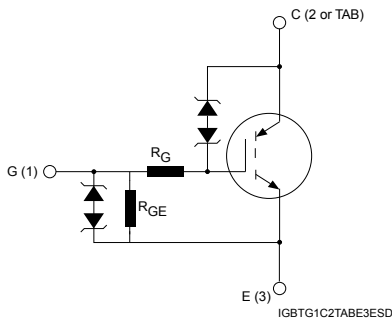

Automotive-grade 360 V internally clamped IGBT E_{SCIS} 300 mJ

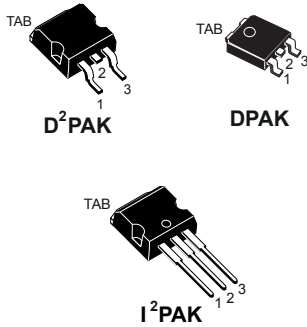

Features

- AEC-Q101 qualified 
- SCIS energy of 300 mJ @ T_J = 25 °C
- Parts are 100% tested in SCIS
- ESD gate-emitter protection
- Gate-collector high voltage clamping
- Logic level gate drive
- Very low saturation voltage
- High pulsed current capability
- Gate and gate-emitter resistor

Applications

- Automotive ignition coil driver circuit

Description

This application-specific IGBT utilizes the most advanced PowerMESH technology optimized for coil driving in the harsh environment of automotive ignition systems. These devices show very low on-state voltage and very high SCIS energy capability over a wide operating temperature range. Moreover, ESD-protected logic level gate input and an integrated gate resistor means no external protection circuitry is required.

Product status link

[STGB25N36LZAG](#)

[STGD25N36LZAG](#)

[STGI25N36LZAG](#)

1 Electrical ratings

Table 1. Absolute maximum ratings

Symbol	Parameter	Value	Unit
V_{CES}	Collector-emitter voltage ($V_{GE} = 0\text{ V}$)	$V_{CES(\text{clamped})}$	V
V_{ECS}	Emitter-collector voltage ($V_{GE} = 0\text{ V}$)	20	V
I_C	Continuous collector current at $T_C = 25\text{ °C}$, $V_{GE} = 4\text{ V}$	25	A
	Continuous collector current at $T_C = 100\text{ °C}$, $V_{GE} = 4\text{ V}$	25	A
$I_{CP}^{(1)}$	Pulsed collector current	50	A
V_{GE}	Gate-emitter voltage	$V_{GE(\text{clamped})}$	V
P_{TOT}	Total power dissipation at $T_C = 25\text{ °C}$	150	W
$E_{SCIS_25}^{(2)}$	Self-clamping inductive switching energy	300	mJ
$E_{SCIS_150}^{(3)}$	Self-clamping inductive switching energy @ $T_J = 150\text{ °C}$	170	mJ
ESD	Human body model, $R = 1.5\text{ k}\Omega$, $C = 100\text{ pF}$	4	kV
	Charged device model	2	kV
T_{STG}	Storage temperature range	-55 to 175	°C
T_J	Operating junction temperature range		°C

1. Pulse width limited by maximum junction temperature.
2. Starting $T_J = 25\text{ °C}$, $L = 3\text{ mH}$, $R_g = 1\text{ k}\Omega$, $V_{cc} = 50\text{ V}$ during inductor charging and $V_{cc} = 0\text{ V}$ during the time in clamp. Parts are 100% electrically tested in production.
3. Starting $T_J = 150\text{ °C}$, $L = 3\text{ mH}$, $R_g = 1\text{ k}\Omega$, $V_{cc} = 50\text{ V}$ during inductor charging and $V_{cc} = 0\text{ V}$ during the time in clamp.

Table 2. Thermal data

Symbol	Parameter	Value			Unit
		D ² PAK	DPAK	I ² PAK	
$R_{thj\text{-case}}$	Thermal resistance junction-case	1			°C/W
$R_{thj\text{-amb}}$	Thermal resistance junction-ambient	62.5	100	62.5	°C/W

2 Electrical characteristics

$T_C = 25\text{ °C}$ unless otherwise specified

Table 3. Static characteristics

Symbol	Parameter	Test conditions	Min.	Typ.	Max.	Unit
$V_{CES(\text{clamped})}$	Collector-emitter clamped voltage	$I_C = 2\text{ mA}, V_{GE} = 0\text{ V}$		350		V
		$I_C = 2\text{ mA}, V_{GE} = 0\text{ V}, T_J = -40\text{ °C to }175\text{ °C}$	325		385	V
$V_{(BR)ECS}$	Emitter-collector break-down voltage	$I_C = 75\text{ mA}, V_{GE} = 0\text{ V}$	20			V
$V_{GE(\text{clamped})}$	Gate-emitter clamped voltage	$I_G = \pm 2\text{ mA}, T_J = -40\text{ °C to }175\text{ °C}$	12		16	V
$V_{CE(\text{sat})}$	Collector-emitter saturation voltage	$V_{GE} = 4\text{ V}, I_C = 6\text{ A}$		1.1	1.25	V
		$V_{GE} = 4.5\text{ V}, I_C = 10\text{ A}, T_J = 175\text{ °C}$		1.25	1.55	V
$V_{GE(\text{th})}$	Gate-threshold voltage	$V_{GE} = V_{CE}, I_C = 1\text{ mA}$	1.3	1.7	2.1	V
		$V_{GE} = V_{CE}, I_C = 1\text{ mA}, T_J = 175\text{ °C}$		1.05		V
I_{CES}	Collector cut-off current	$V_{CE} = 15\text{ V}, V_{GE} = 0\text{ V}, T_J = 150\text{ °C}$			20	μA
		$V_{CE} = 200\text{ V}, V_{GE} = 0\text{ V}, T_J = 150\text{ °C}$			100	μA
I_{GES}	Gate-emitter leakage current	$V_{GE} = \pm 10\text{ V}, V_{CE} = 0\text{ V}$		625		μA
		$V_{GE} = \pm 10\text{ V}, V_{CE} = 0\text{ V}, T_J = -40\text{ °C to }175\text{ °C}$	450		900	μA
R_{GE}	Gate emitter resistance		11	16	22	k Ω
R_G	Gate resistance			120		Ω

Table 4. Dynamic characteristics

Symbol	Parameter	Test conditions	Min.	Typ.	Max.	Unit
C_{ies}	Input capacitance	$V_{CE} = 25\text{ V}, f = 1\text{ MHz}, V_{GE} = 0\text{ V}$	-	1004	-	pF
C_{oes}	Output capacitance		-	86.6	-	
C_{res}	Reverse transfer capacitance		-	14	-	
Q_g	Total gate charge	$V_{CE} = 13\text{ V}, I_C = 10\text{ A}, V_{GE} = 0\text{ to }5\text{ V}$	-	25.7	-	nC

Table 5. Resistive load switching characteristics

Symbol	Parameter	Test conditions	Min.	Typ.	Max.	Unit
$t_{d(on)}$	Turn-on delay time	$V_{CC} = 14\text{ V}$, $V_{GE} = 5\text{ V}$,	-	1.1	-	μs
t_r	Current rise time	$R_L = 1\ \Omega$, $R_G = 1\ \text{k}\Omega$ (see Figure 17. Test circuit for resistive load switching)	-	3.6	-	μs
$t_{d(on)}$	Turn-on delay time	$V_{CC} = 14\text{ V}$, $V_{GE} = 5\text{ V}$,	-	1.06	-	μs
t_r	Current rise time	$R_L = 1\ \Omega$, $R_G = 1\ \text{k}\Omega$, $T_J = 150\text{ }^\circ\text{C}$ (see Figure 17. Test circuit for resistive load switching)	-	3.5	-	μs

Table 6. Inductive load switching characteristics

Symbol	Parameter	Test conditions	Min.	Typ.	Max.	Unit
$t_{d(off)}$	Turn-off delay time	$V_{CC} = 300\text{ V}$, $L = 1\ \text{mH}$,	-	7.4	-	ns
t_f	Current fall time	$I_C = 10\text{ A}$, $V_{GE} = 5\text{ V}$, $R_G = 1\ \text{k}\Omega$	-	5.1	-	ns
dV/dt	Turn-off voltage slope	(see Figure 16. Test circuit for inductive load switching)	-	160.3	-	V/ns
$t_{d(off)}$	Turn-off delay time	$V_{CC} = 300\text{ V}$, $L = 1\ \text{mH}$,	-	7.5	-	ns
t_f	Current fall time	$I_C = 10\text{ A}$, $V_{GE} = 5\text{ V}$, $R_G = 1\ \text{k}\Omega$, $T_J = 150\text{ }^\circ\text{C}$	-	7	-	ns
dV/dt	Turn-off voltage slope	(see Figure 16. Test circuit for inductive load switching)	-	144.7	-	V/ns

2.1 Electrical characteristics (curves)
Figure 1. $V_{CE(sat)}$ vs junction temperature ($I_C = 6\text{ A}$)

Figure 2. $V_{CE(sat)}$ vs junction temperature ($I_C = 10\text{ A}$)

Figure 3. Self-clamped inductive switching current

Figure 4. Output characteristics ($T_J = 25\text{ }^{\circ}\text{C}$)

Figure 5. Output characteristics ($T_J = -40\text{ }^{\circ}\text{C}$)

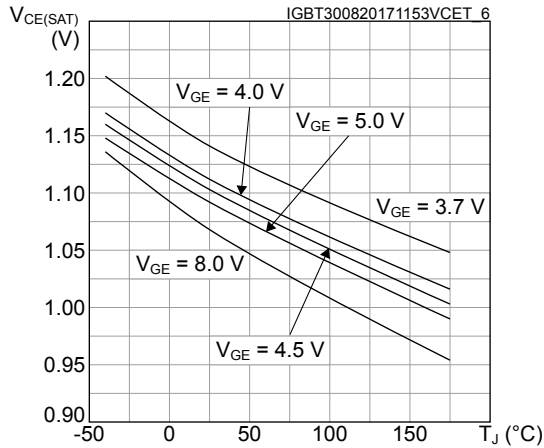
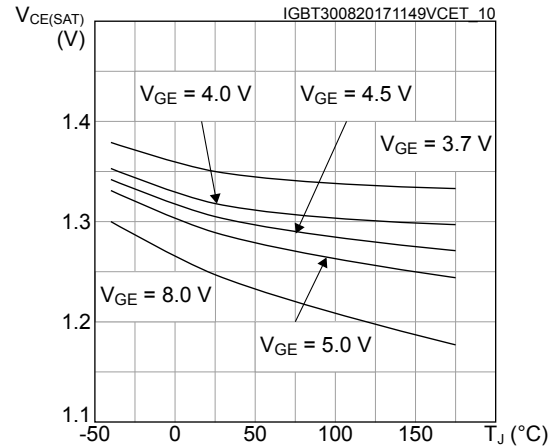
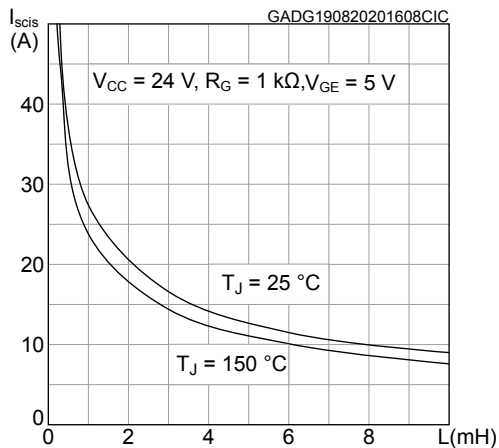
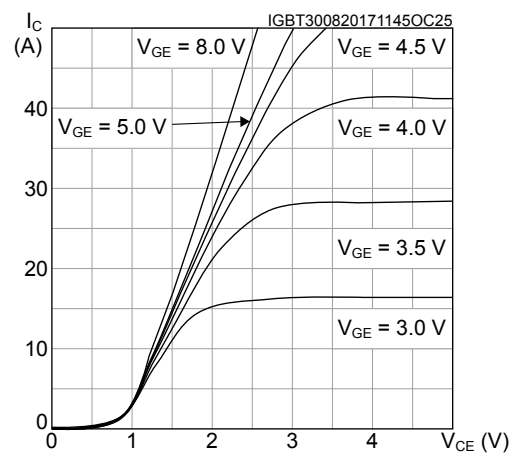
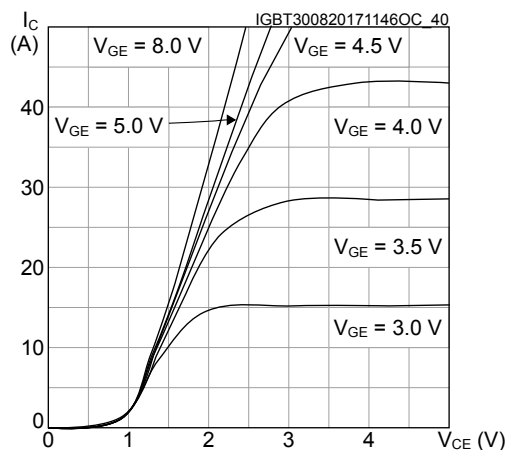
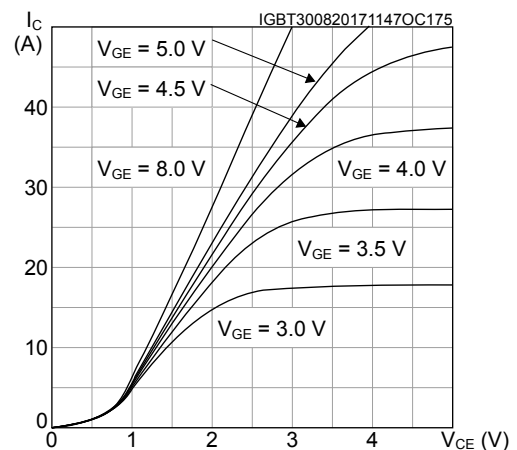
Figure 6. Output characteristics ($T_J = 175\text{ }^{\circ}\text{C}$)

Figure 7. Transfer characteristics

Figure 8. Collector current vs case temperature

Figure 9. Leakage current vs temperature

Figure 10. Normalized VCES(clamped) vs temperature

Figure 11. Normalized VGE(th) vs temperature

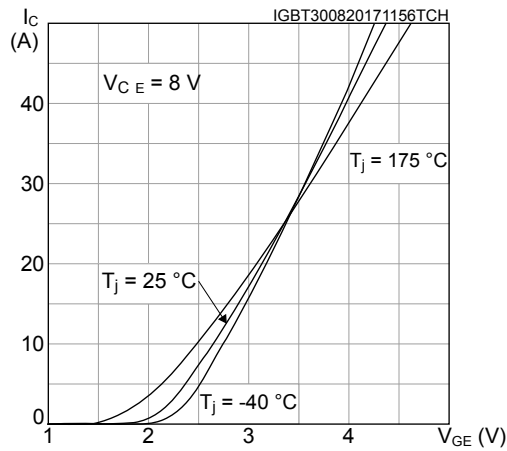
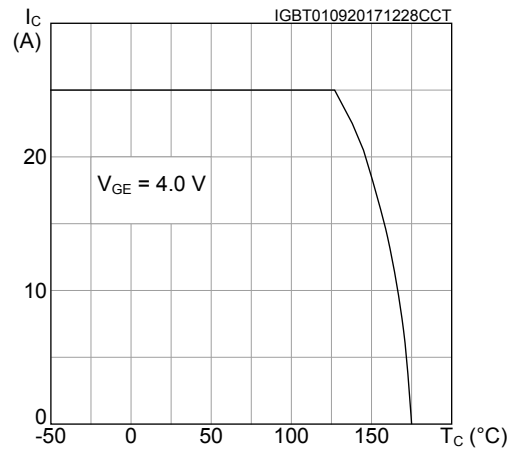
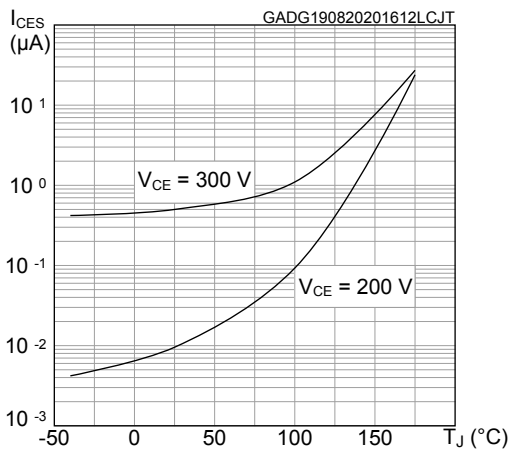
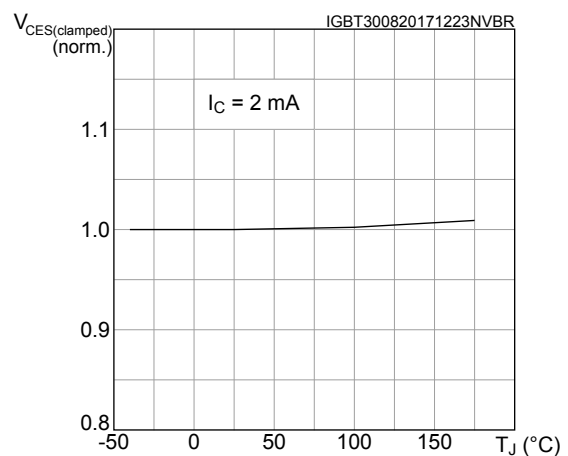
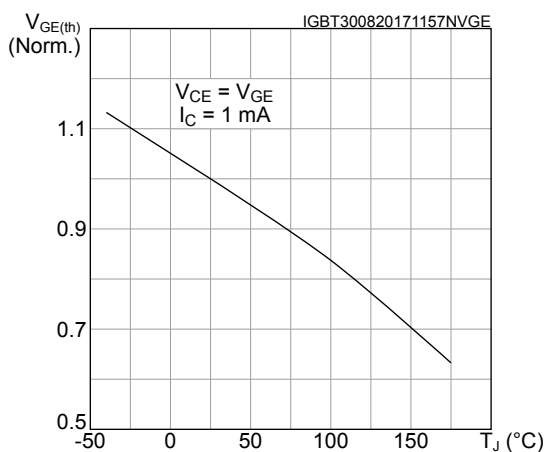
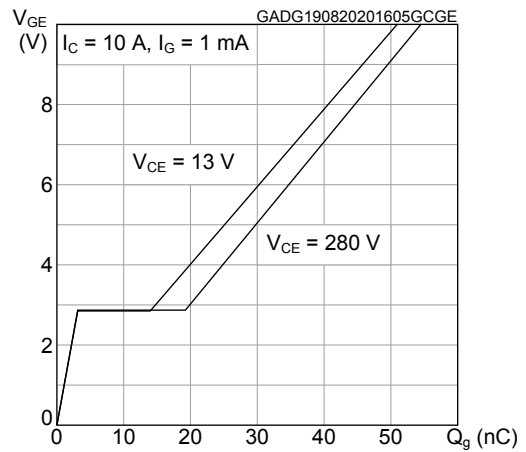
Figure 12. Gate charge vs gate-emitter voltage

Figure 13. Capacitance variations

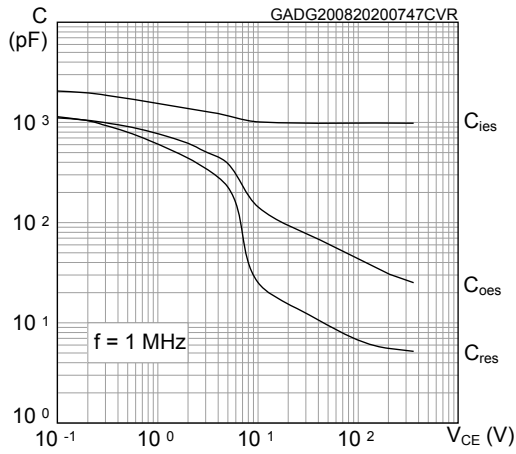

Figure 14. Thermal impedance for D²PAK and I²PAK

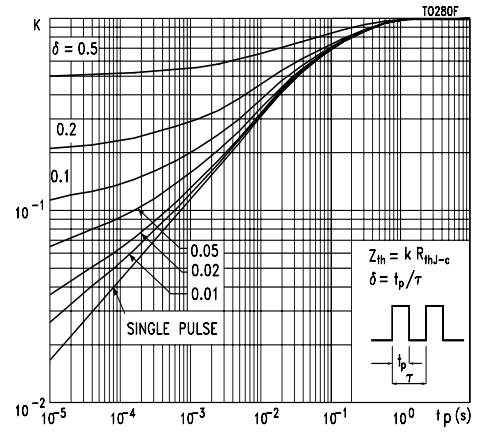
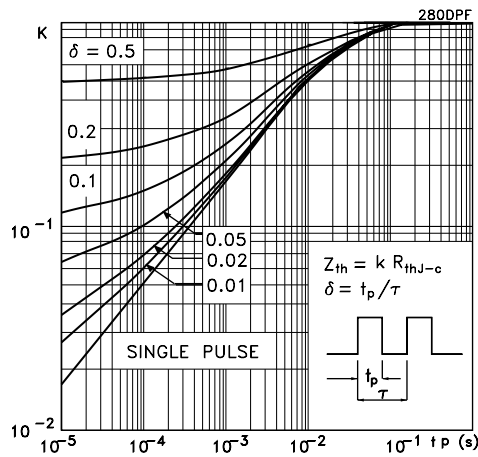

Figure 15. Thermal impedance for DPAK



3 Test circuits

Figure 16. Test circuit for inductive load switching

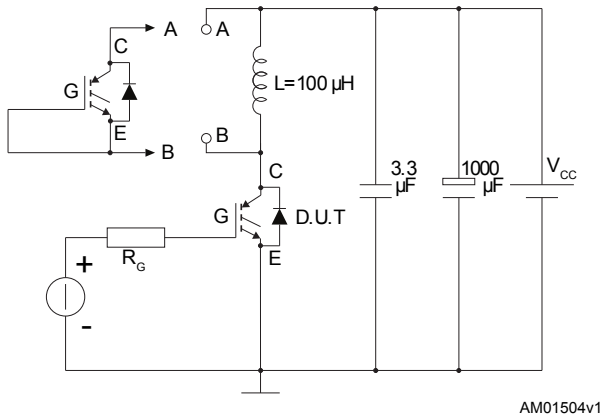

Figure 17. Test circuit for resistive load switching

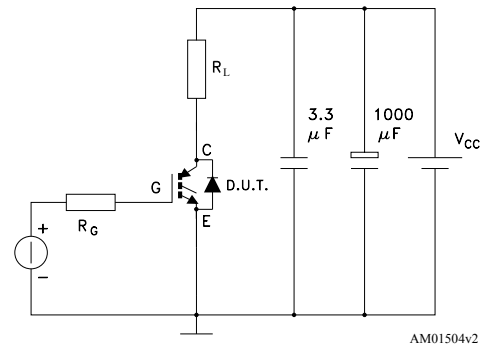

Figure 18. Gate charge test circuit

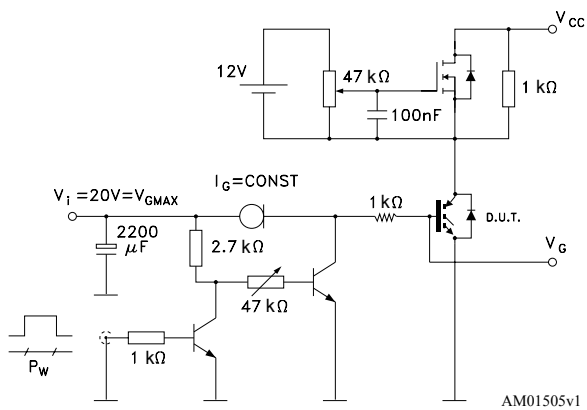
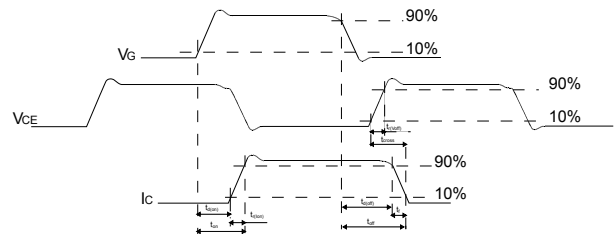

Figure 19. Switching waveform



4 Package information

In order to meet environmental requirements, ST offers these devices in different grades of **ECOPACK** packages, depending on their level of environmental compliance. ECOPACK specifications, grade definitions and product status are available at: www.st.com. ECOPACK is an ST trademark.

4.1 D²PAK (TO-263) type A package information

Figure 20. D²PAK (TO-263) type A package outline

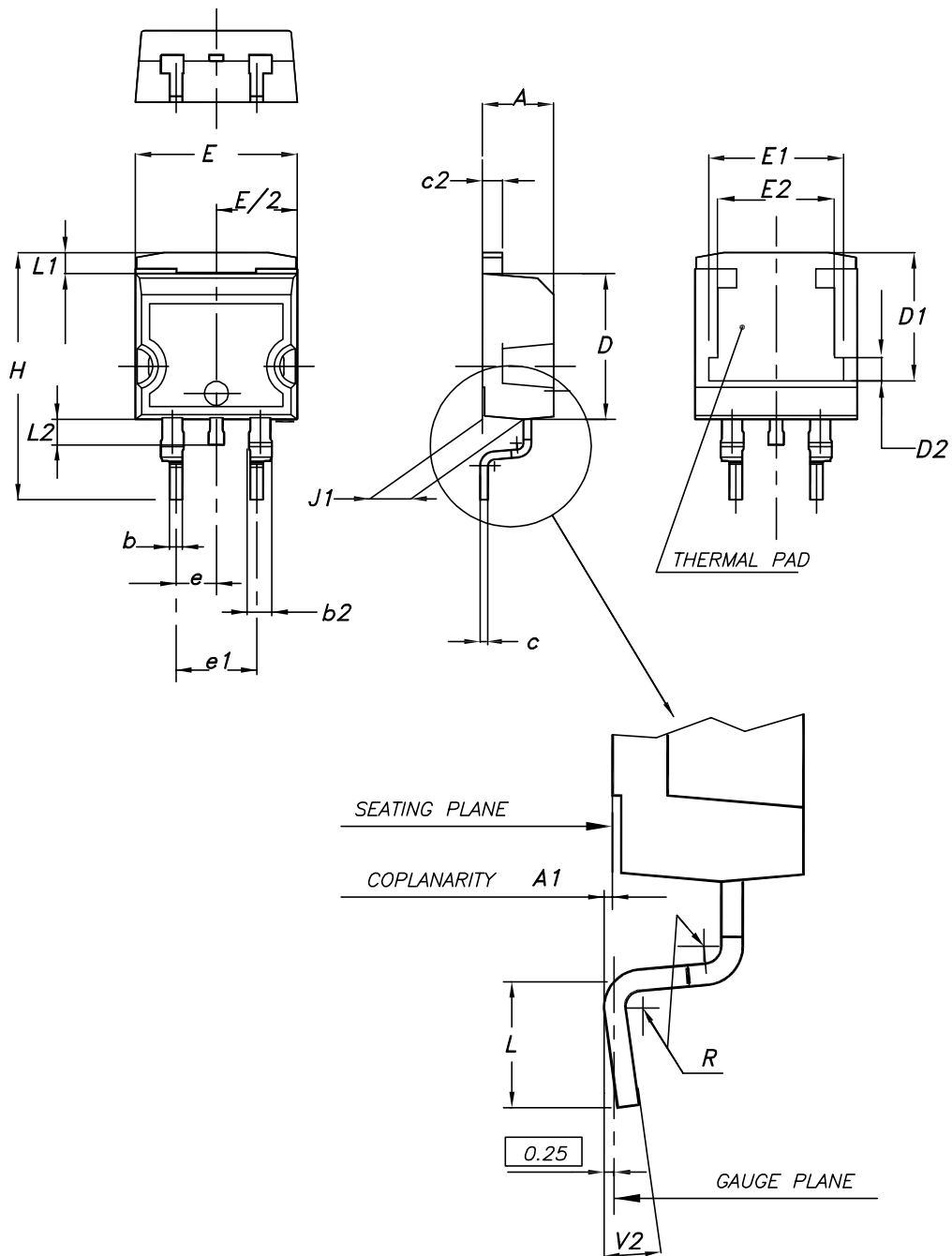

0079457_26

Table 7. D²PAK (TO-263) type A package mechanical data

Dim.	mm		
	Min.	Typ.	Max.
A	4.40		4.60
A1	0.03		0.23
b	0.70		0.93
b2	1.14		1.70
c	0.45		0.60
c2	1.23		1.36
D	8.95		9.35
D1	7.50	7.75	8.00
D2	1.10	1.30	1.50
E	10.00		10.40
E1	8.30	8.50	8.70
E2	6.85	7.05	7.25
e		2.54	
e1	4.88		5.28
H	15.00		15.85
J1	2.49		2.69
L	2.29		2.79
L1	1.27		1.40
L2	1.30		1.75
R		0.40	
V2	0°		8°

Figure 21. D²PAK (TO-263) recommended footprint (dimensions are in mm)

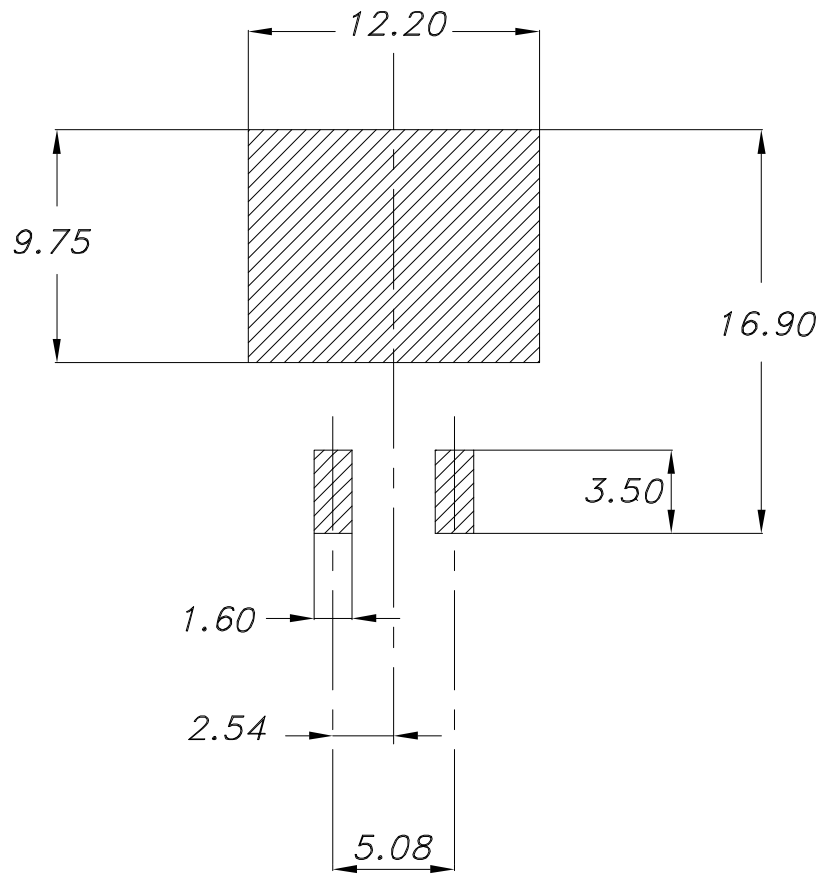

Footprint_26

4.2 DPAK (TO-252) type A2 package information

Figure 22. DPAK (TO-252) type A2 package outline

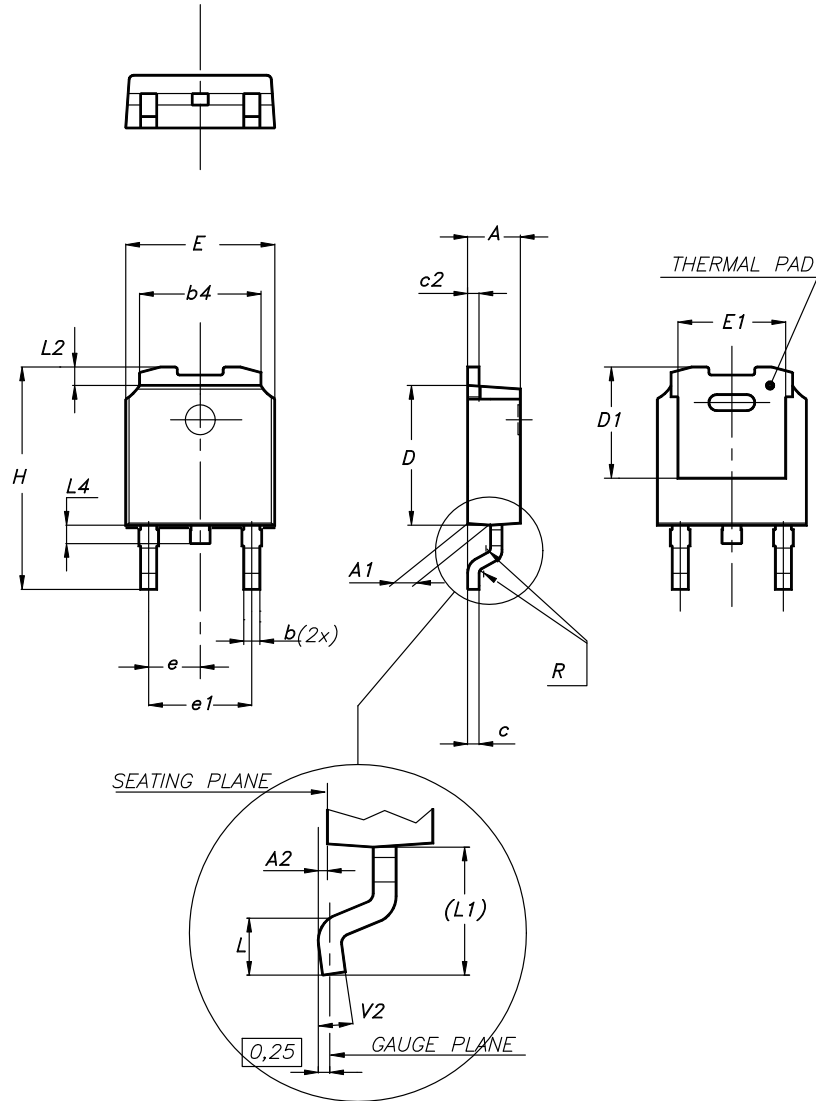

0068772_type-A2_rev29

Table 8. DPAK (TO-252) type A2 mechanical data

Dim.	mm		
	Min.	Typ.	Max.
A	2.20		2.40
A1	0.90		1.10
A2	0.03		0.23
b	0.64		0.90
b4	5.20		5.40
c	0.45		0.60
c2	0.48		0.60
D	6.00		6.20
D1	4.95	5.10	5.25
E	6.40		6.60
E1	5.10	5.20	5.30
e	2.159	2.286	2.413
e1	4.445	4.572	4.699
H	9.35		10.10
L	1.00		1.50
L1	2.60	2.80	3.00
L2	0.65	0.80	0.95
L4	0.60		1.00
R		0.20	
V2	0°		8°

Figure 23. DPAK (TO-252) recommended footprint (dimensions are in mm)

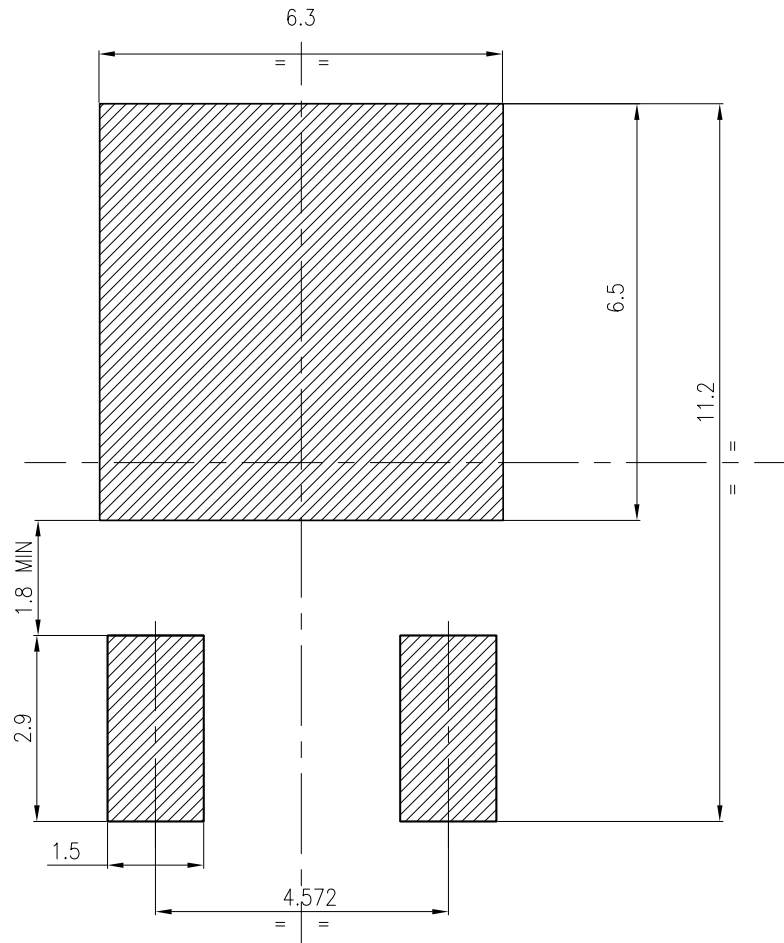

FP_0068772_29

4.3 I²PAK package information

Figure 24. I²PAK package outline

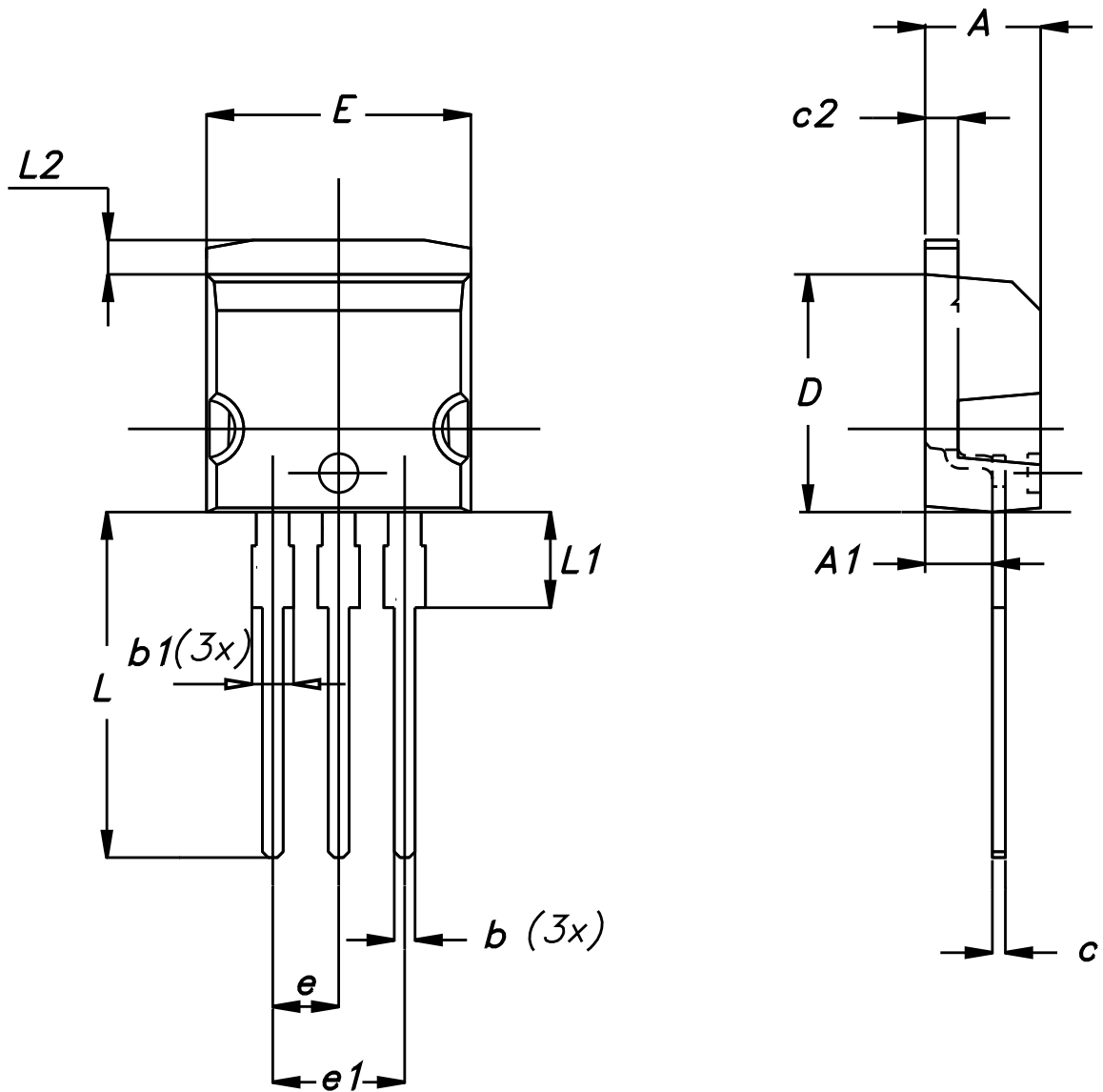

0004982_Rev_9

Table 9. I²PAK package mechanical data

Dim.	mm		
	Min.	Typ.	Max.
A	4.40	-	4.60
A1	2.40	-	2.72
b	0.61	-	0.88
b1	1.14	-	1.70
c	0.49	-	0.70
c2	1.23	-	1.32
D	8.95	-	9.35
e	2.40	-	2.70
e1	4.95	-	5.15
E	10	-	10.40
L	13	-	14
L1	3.50	-	3.93
L2	1.27	-	1.40

4.4 D²PAK and DPAK packing information

Figure 25. Tape outline

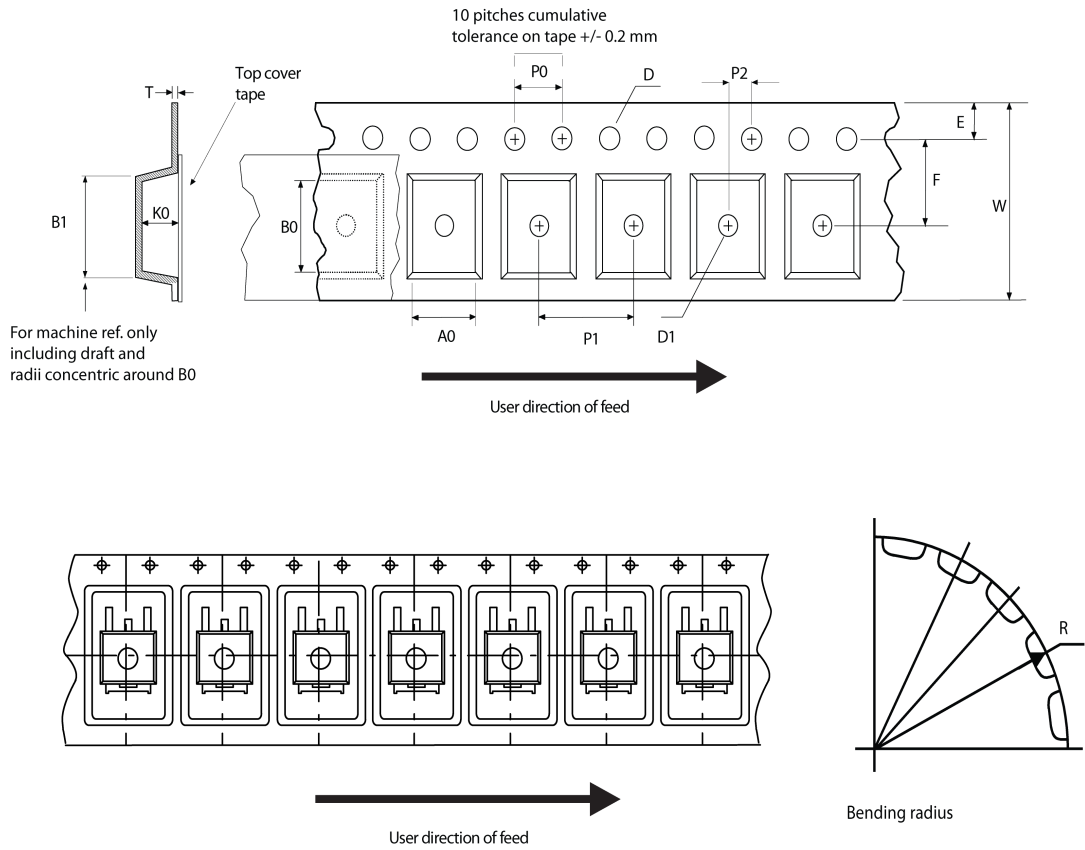

AM08852v1

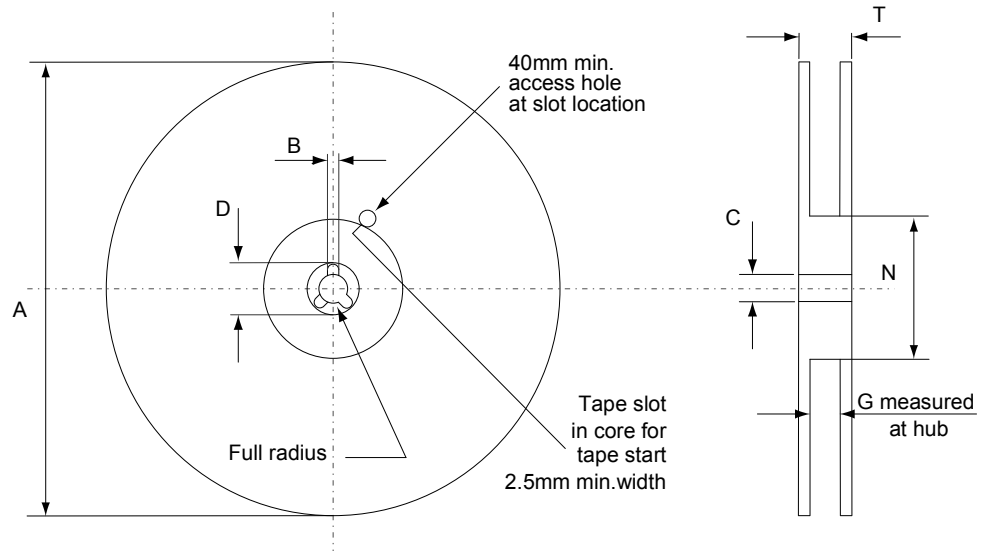
Figure 26. Reel outline

AM06038v1

Table 10. D²PAK tape and reel mechanical data

Tape			Reel			
Dim.	mm		Dim.	mm		
	Min.	Max.		Min.	Max.	
A0	10.5	10.7	A		330	
B0	15.7	15.9	B	1.5		
D	1.5	1.6	C	12.8	13.2	
D1	1.59	1.61	D	20.2		
E	1.65	1.85	G	24.4	26.4	
F	11.4	11.6	N	100		
K0	4.8	5.0	T		30.4	
P0	3.9	4.1	Base quantity Bulk quantity			
P1	11.9	12.1				1000
P2	1.9	2.1				1000
R	50					
T	0.25	0.35				
W	23.7	24.3				

Table 11. DPAK tape and reel mechanical data

Tape			Reel		
Dim.	mm		Dim.	mm	
	Min.	Max.		Min.	Max.
A0	6.8	7	A		330
B0	10.4	10.6	B	1.5	
B1		12.1	C	12.8	13.2
D	1.5	1.6	D	20.2	
D1	1.5		G	16.4	18.4
E	1.65	1.85	N	50	
F	7.4	7.6	T		22.4
K0	2.55	2.75			
P0	3.9	4.1	Base qty.		2500
P1	7.9	8.1	Bulk qty.		2500
P2	1.9	2.1			
R	40				
T	0.25	0.35			
W	15.7	16.3			

5 Ordering information

Table 12. Order codes

Order code	Marking	Package	Packing
STGB25N36LZAG	GB25N36LZ	D ² PAK	Tape and reel
STGD25N36LZAG	GD25N36LZ	DPAK	Tape and reel
STGI25N36LZAG	GI25N36LZ	I ² PAK	Tube

Revision history

Table 13. Document revision history

Date	Revision	Changes
19-Aug-2020	1	First release.

Contents

1	Electrical ratings	2
2	Electrical characteristics	3
2.1	Electrical characteristics (curves).....	5
3	Test circuits	8
4	Package information	9
4.1	D ² PAK (TO-263) type A package information	9
4.2	DPAK (TO-252) type A2 package information	12
4.3	I ² PAK package information.....	15
4.4	D ² PAK and DPAK packing information	17
5	Ordering information	20
	Revision history	21