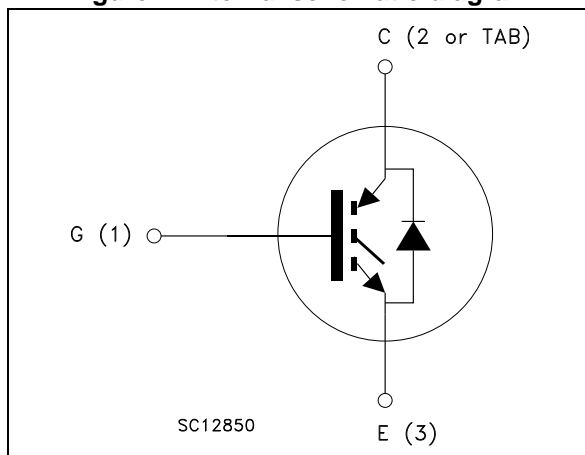

Figure 1. Internal schematic diagram



Features

- Low on-voltage drop ($V_{CE(sat)}$)
- Very soft ultrafast recovery anti-parallel diode

Applications

- High frequency motor drives
- SMPS and PFC in both hard switch and resonant topologies

Description

These devices are ultrafast IGBT. They utilize the advanced Power MESH™ process resulting in an excellent trade-off between switching performance and low on-state behavior.

Table 1. Device summary

Part numbers	Marking	Package	Packing
STGB19NC60HDT4	GB19NC60HD	D ² PAK	Tape and reel
STGF19NC60HD	GF19NC60HD	TO-220FP	Tube
STGP19NC60HD	GP19NC60HD	TO-220	Tube
STGW19NC60HD	GW19NC60HD	TO-247	Tube

Contents

- 1 Electrical ratings 3**
- 2 Electrical characteristics 4**
 - 2.1 Electrical characteristics (curves) 7
- 3 Test circuits 10**
- 4 Package information 11**
 - 4.1 D²PAK (TO-263) package information11
 - 4.2 TO-220FP package information 14
 - 4.3 TO-220 package information 16
 - 4.4 TO-247 package information 18
- 5 Packing information 20**
- 6 Revision history 22**

1 Electrical ratings

Table 2. Absolute maximum ratings

Symbol	Parameter	Value			Unit
		TO-220 D ² PAK	TO-220FP	TO-247	
V _{CES}	Collector-emitter voltage (V _{GE} = 0)	600			V
I _C ⁽¹⁾	Continuous collector current at T _C = 25 °C	40	16	42	A
I _C ⁽¹⁾	Continuous collector current at T _C = 100 °C	19	10	21	A
I _{CL} ⁽²⁾	Turn-off latching current	40			A
I _{CP} ⁽³⁾	Pulsed collector current	60			A
I _F	Diode RMS forward current at T _C = 25 °C	20			A
I _{FSM}	Surge not repetitive forward current t _p =10 ms sinusoidal	50			A
V _{GE}	Gate-emitter voltage	±20			V
P _{TOT}	Total dissipation at T _C = 25 °C	130	32	140	W
V _{ISO}	Isolation withstand voltage (RMS) from all three leads to external heat sink (t = 1 s; T _C = 25 °C)	2500			V
T _{STG}	Storage temperature range	- 55 to 150			°C
T _J	Operating junction temperature range				

1. Calculated according to the iterative formula:

$$I_C(T_C) = \frac{T_{j(max)} - T_C}{R_{thj-c} \times V_{CE(sat)(max)}(T_{j(max)}, I_C(T_C))}$$

2. V_{clamp} = 80%V_{CES}, T_J = 150 °C, R_G = 1 0 Ω, V_{GE} = 15 V

3. Pulse width limited by maximum permissible junction temperature and turn-off within RBSOA.

Table 3. Thermal data

Symbol	Parameter	Value			Unit
		TO-220 D ² PAK	TO-220FP	TO-247	
R _{thj-case}	Thermal resistance junction-case IGBT	0.95	3.9	0.9	°C/W
	Thermal resistance junction-case diode	3	5.5	3	°C/W
R _{thj-amb}	Thermal resistance junction-ambient	62.5		50	°C/W

2 Electrical characteristics

($T_J = 25\text{ °C}$ unless otherwise specified)

Table 4. Static

Symbol	Parameter	Test conditions	Min.	Typ.	Max.	Unit
$V_{(BR)CES}$	Collector-emitter breakdown voltage ($V_{GE} = 0$)	$I_C = 1\text{ mA}$	600			V
$V_{CE(sat)}$	Collector-emitter saturation voltage	$V_{GE} = 15\text{ V}, I_C = 12\text{ A}$		1.8	2.5	V
		$V_{GE} = 15\text{ V}, I_C = 15\text{ A}$		2		
		$V_{GE} = 15\text{ V}, I_C = 30\text{ A}, T_J = 100\text{ °C}$		2.5		
		$V_{GE} = 15\text{ V}, I_C = 12\text{ A}, T_J = 125\text{ °C}$		1.6		
$V_{GE(th)}$	Gate threshold voltage	$V_{CE} = V_{GE}, I_C = 250\text{ }\mu\text{A}$	3.75		5.75	
I_{CES}	Collector cut-off current ($V_{GE} = 0$)	$V_{CE} = 600\text{ V}$			150	μA
		$V_{CE} = 600\text{ V}, T_J = 125\text{ °C}$			1	mA
I_{GES}	Gate-emitter leakage current ($V_{CE} = 0$)	$V_{GE} = \pm 20\text{ V}$			± 100	nA
$g_{fs}^{(1)}$	Forward transconductance	$V_{CE} = 15\text{ V}, I_C = 12\text{ A}$		5		S

1. Pulsed: pulse duration = 300 μs , duty cycle 1.5%

Table 5. Dynamic

Symbol	Parameter	Test conditions	Min.	Typ.	Max.	Unit
C_{ies}	Input capacitance	$V_{CE} = 25\text{ V}, f = 1\text{ MHz}, V_{GE} = 0$	-	1180	-	pF
C_{oes}	Output capacitance		-	130	-	
C_{res}	Reverse transfer capacitance		-	36	-	
Q_g	Total gate charge	$V_{CE} = 390\text{ V}, I_C = 5\text{ A}, V_{GE} = 15\text{ V}$, (see Figure 20)	-	53	-	nC
Q_{ge}	Gate-emitter charge		-	10	-	
Q_{gc}	Gate-collector charge		-	23	-	

Table 6. Switching on/off (inductive load)

Symbol	Parameter	Test conditions	Min.	Typ.	Max.	Unit
$t_{d(on)}$	Turn-on delay time	$V_{CC} = 390\text{ V}$, $I_C = 12\text{ A}$ $R_G = 10\ \Omega$, $V_{GE} = 15\text{ V}$ (see Figure 21)	-	25	-	ns
t_r	Current rise time		-	7	-	
$(di/dt)_{on}$	Turn-on current slope		-	1600	-	A/ μ s
$t_{d(on)}$	Turn-on delay time	$V_{CC} = 390\text{ V}$, $I_C = 12\text{ A}$ $R_G = 10\ \Omega$, $V_{GE} = 15\text{ V}$, $T_J = 125\text{ }^\circ\text{C}$ (see Figure 21)	-	24	-	ns
t_r	Current rise time		-	8	-	
$(di/dt)_{on}$	Turn-on current slope		-	1400	-	A/ μ s
$t_{r(Voff)}$	Off voltage rise time	$V_{CC} = 390\text{ V}$, $I_C = 12\text{ A}$ $R_G = 10\ \Omega$, $V_{GE} = 15\text{ V}$, (see Figure 21)	-	27	-	ns
$t_{d(Voff)}$	Turn-off delay time		-	97	-	
t_f	Current fall time		-	73	-	
$t_{r(Voff)}$	Off voltage rise time	$V_{CC} = 390\text{ V}$, $I_C = 12\text{ A}$ $R_G = 10\ \Omega$, $V_{GE} = 15\text{ V}$, $T_J = 125\text{ }^\circ\text{C}$ (see Figure 21)	-	58	-	ns
$t_{d(Voff)}$	Turn-off delay time		-	144	-	
t_f	Current fall time		-	128	-	

Table 7. Switching energy (inductive load)

Symbol	Parameter	Test conditions	Min.	Typ.	Max.	Unit
E_{on}	Turn-on switching energy	$V_{CC} = 390\text{ V}$, $I_C = 12\text{ A}$ $R_G = 10\ \Omega$, $V_{GE} = 15\text{ V}$, (see Figure 21)	-	85	-	μ J
$E_{off}^{(1)}$	Turn-off switching energy		-	189	-	
E_{ts}	Total switching energy		-	274	-	
E_{on}	Turn-on switching energy	$V_{CC} = 390\text{ V}$, $I_C = 12\text{ A}$ $R_G = 10\ \Omega$, $V_{GE} = 15\text{ V}$, $T_J = 125\text{ }^\circ\text{C}$ (see Figure 21)	-	187	-	μ J
$E_{off}^{(1)}$	Turn-off switching energy		-	407	-	
E_{ts}	Total switching energy		-	594	-	

1. Including the tail of the collector current.

Table 8. Collector-emitter diode

Symbol	Parameter	Test conditions	Min.	Typ.	Max.	Unit
V_F	Forward on-voltage	$I_F = 12\text{ A}$	-	2.6	-	V
		$I_F = 12\text{ A}, T_J = 125\text{ °C}$	-	2.1	-	
t_{rr}	Reverse recovery time	$I_F = 12\text{ A}, V_R = 40\text{ V},$ $di/dt = 100\text{ A}/\mu\text{s}$ (see Figure 22)	-	31	-	ns
Q_{rr}	Reverse recovery charge		-	30	-	nC
I_{rrm}	Reverse recovery current		-	2	-	A
t_{rr}	Reverse recovery time	$I_F = 12\text{ A}, V_R = 40\text{ V},$ $T_J = 125\text{ °C}, di/dt = 100\text{ A}/\mu\text{s}$ (see Figure 22)	-	59	-	ns
Q_{rr}	Reverse recovery charge		-	102	-	nC
I_{rrm}	Reverse recovery current		-	4	-	A

2.1 Electrical characteristics (curves)

Figure 2. Output characteristics

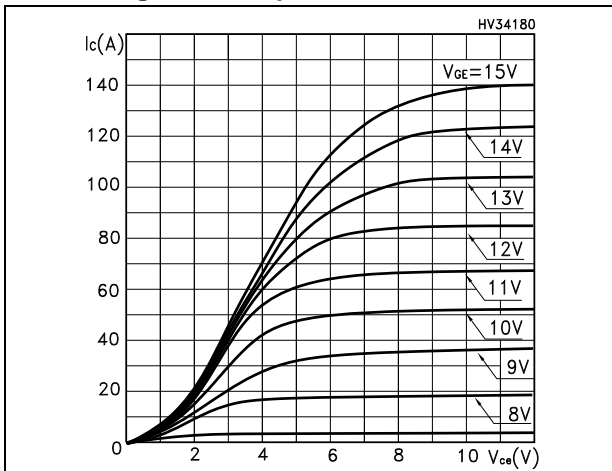

Figure 3. Transfer characteristics

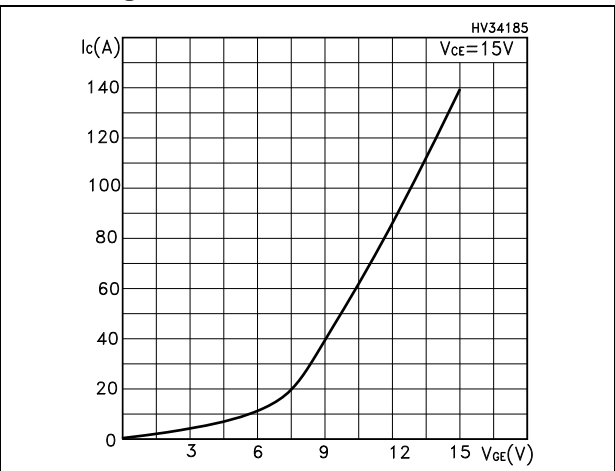

Figure 4. Transconductance

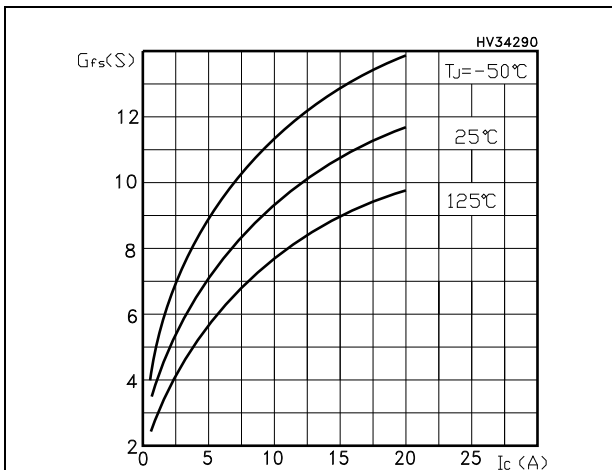

Figure 5. Collector-emitter on voltage vs. temperature

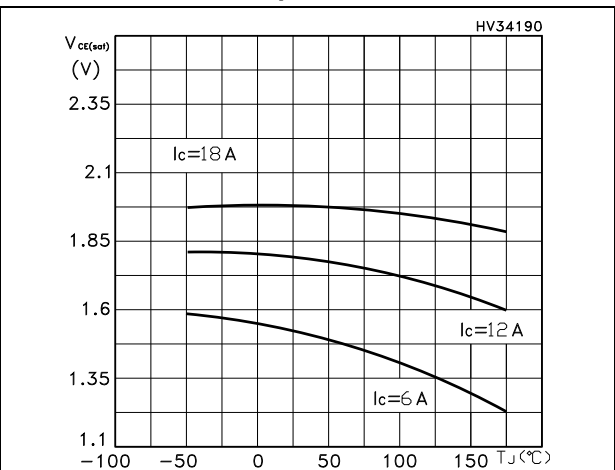

Figure 6. Gate charge vs. gate-source voltage

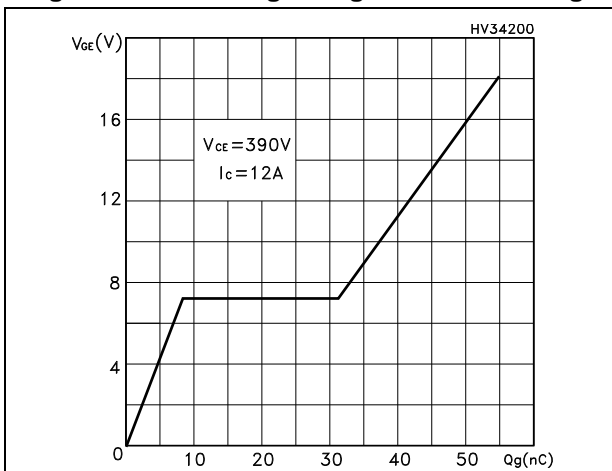

Figure 7. Capacitance variations

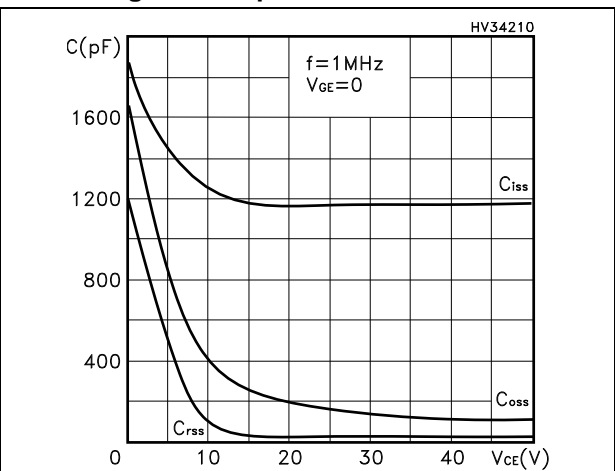

Figure 8. Normalized gate threshold voltage vs. temperature

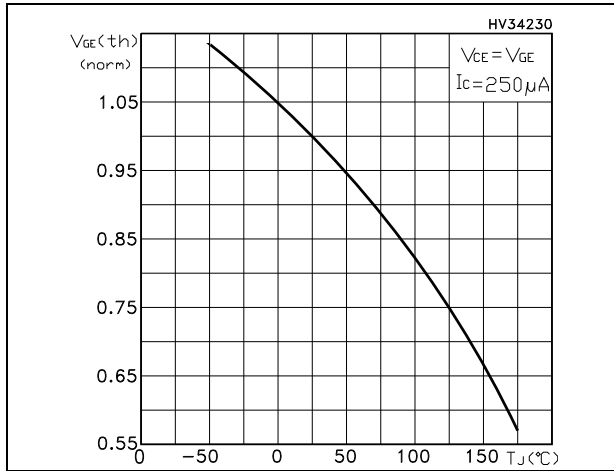

Figure 9. Collector-emitter on voltage vs. collector current

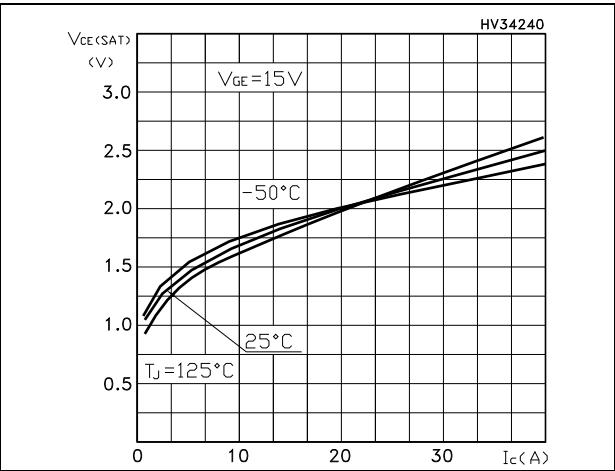

Figure 10. Normalized breakdown voltage vs. temperature

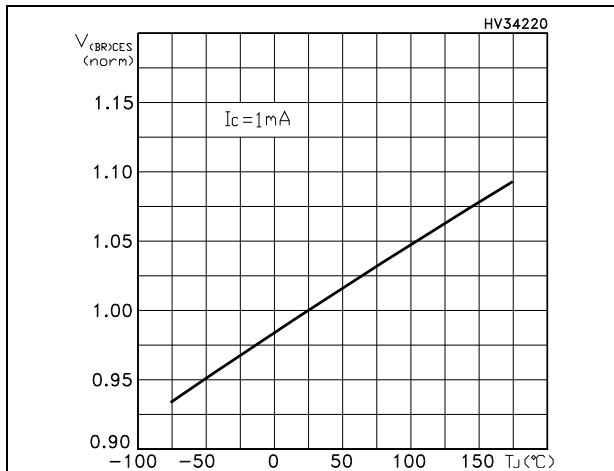

Figure 11. Switching energy vs. temperature

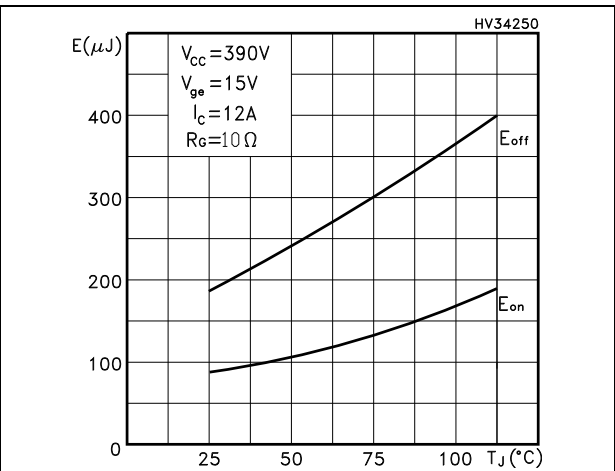

Figure 12. Switching energy vs. gate resistance

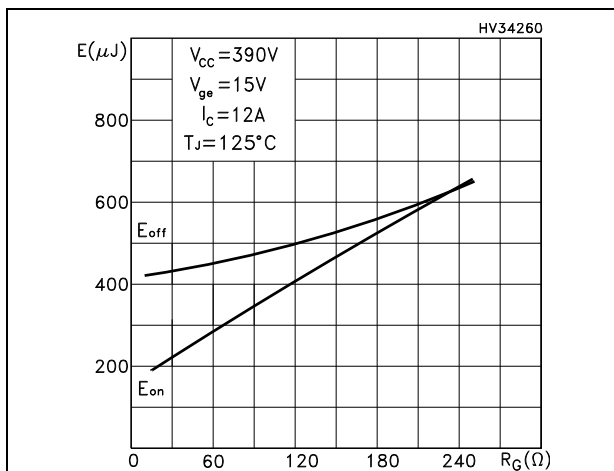

Figure 13. Switching energy vs. collector current

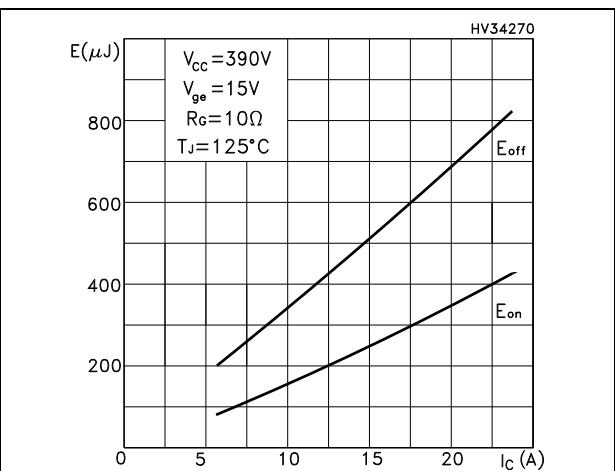

Figure 14. Turn-off SOA

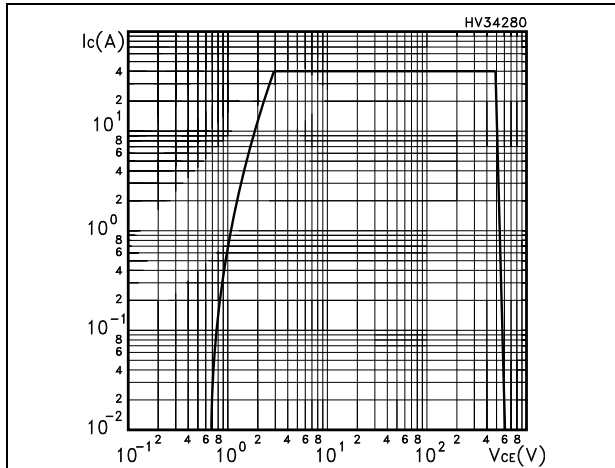

Figure 15. Thermal impedance for TO-247

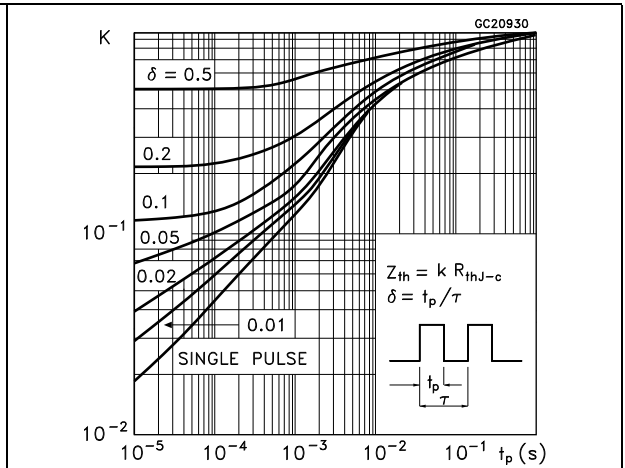

Figure 16. Thermal impedance for TO-220, D²PAK

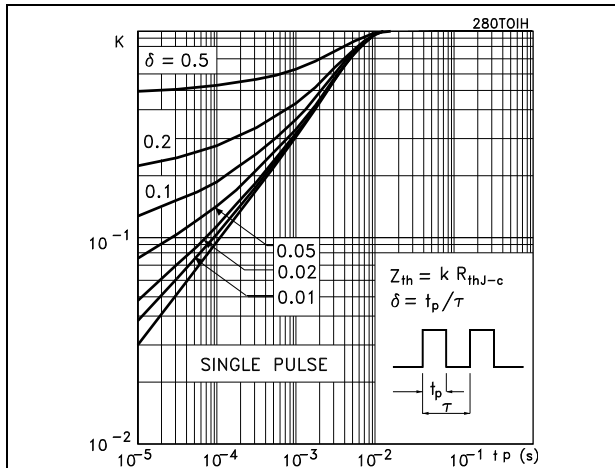

Figure 17. Thermal impedance for TO-220FP

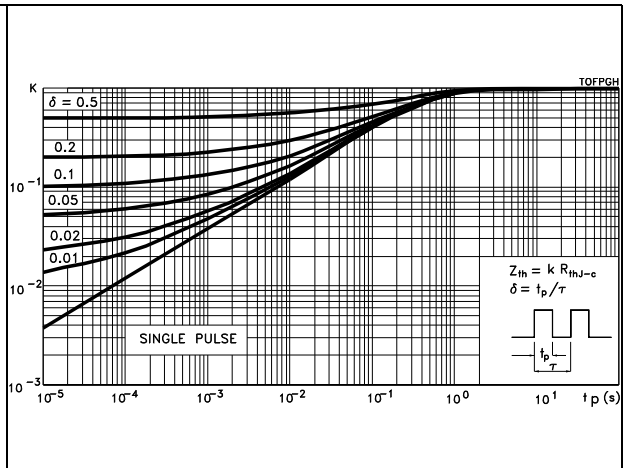
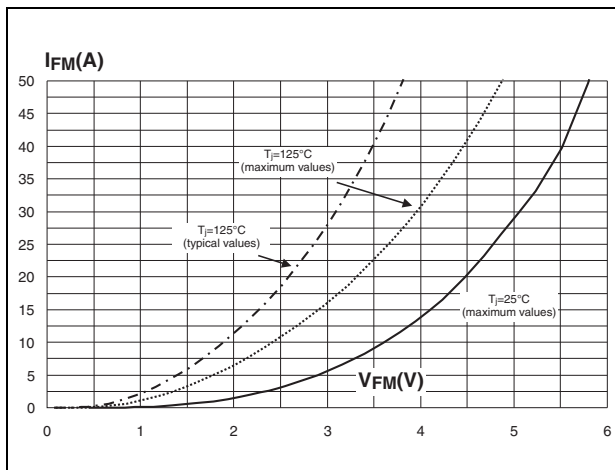

Figure 18. Forward voltage drop vs. forward current



3 Test circuits

Figure 19. Test circuit for inductive load switching

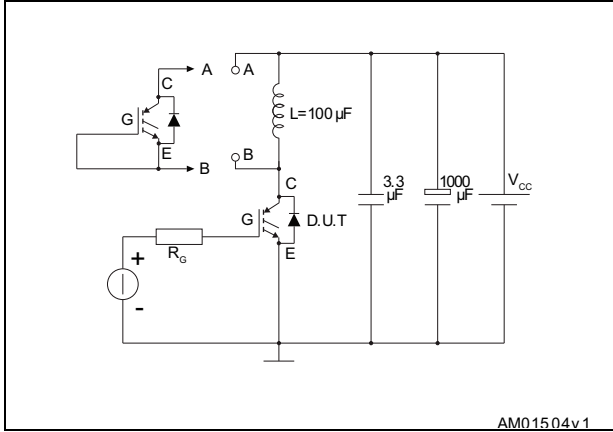

Figure 20. Gate charge test circuit

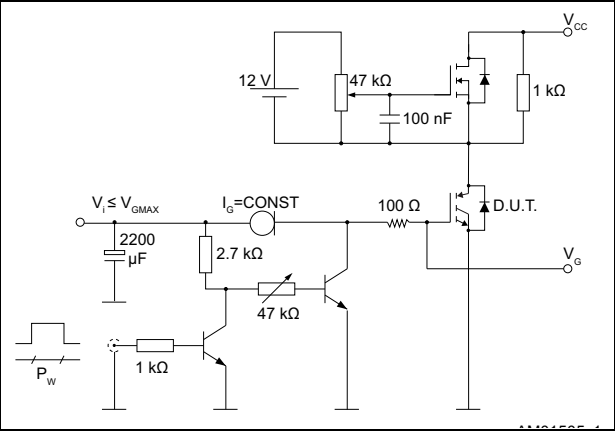

Figure 21. Switching waveform

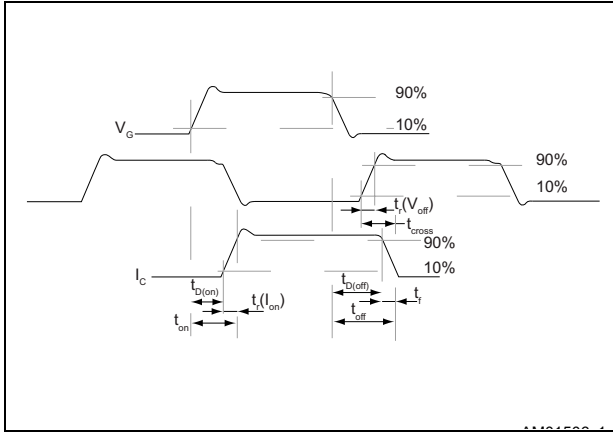
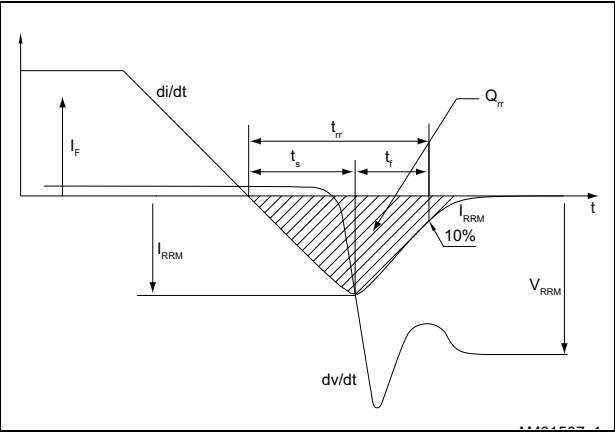

Figure 22. Diode recovery time waveform



4 Package information

In order to meet environmental requirements, ST offers these devices in different grades of ECOPACK[®] packages, depending on their level of environmental compliance. ECOPACK[®] specifications, grade definitions and product status are available at: www.st.com. ECOPACK is an ST trademark.

4.1 D²PAK (TO-263) package information

Figure 23. D²PAK (TO-263) type A package outline

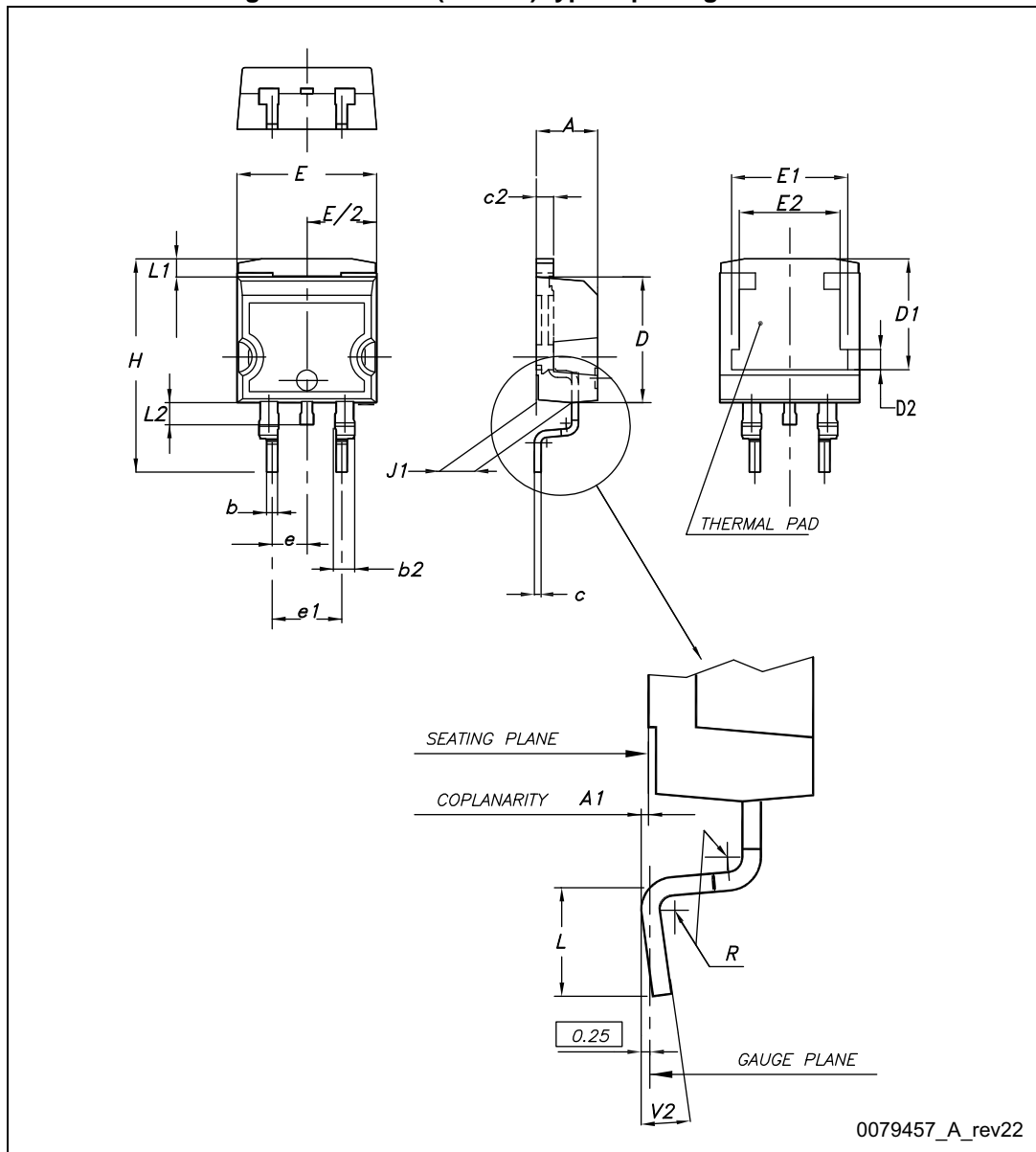
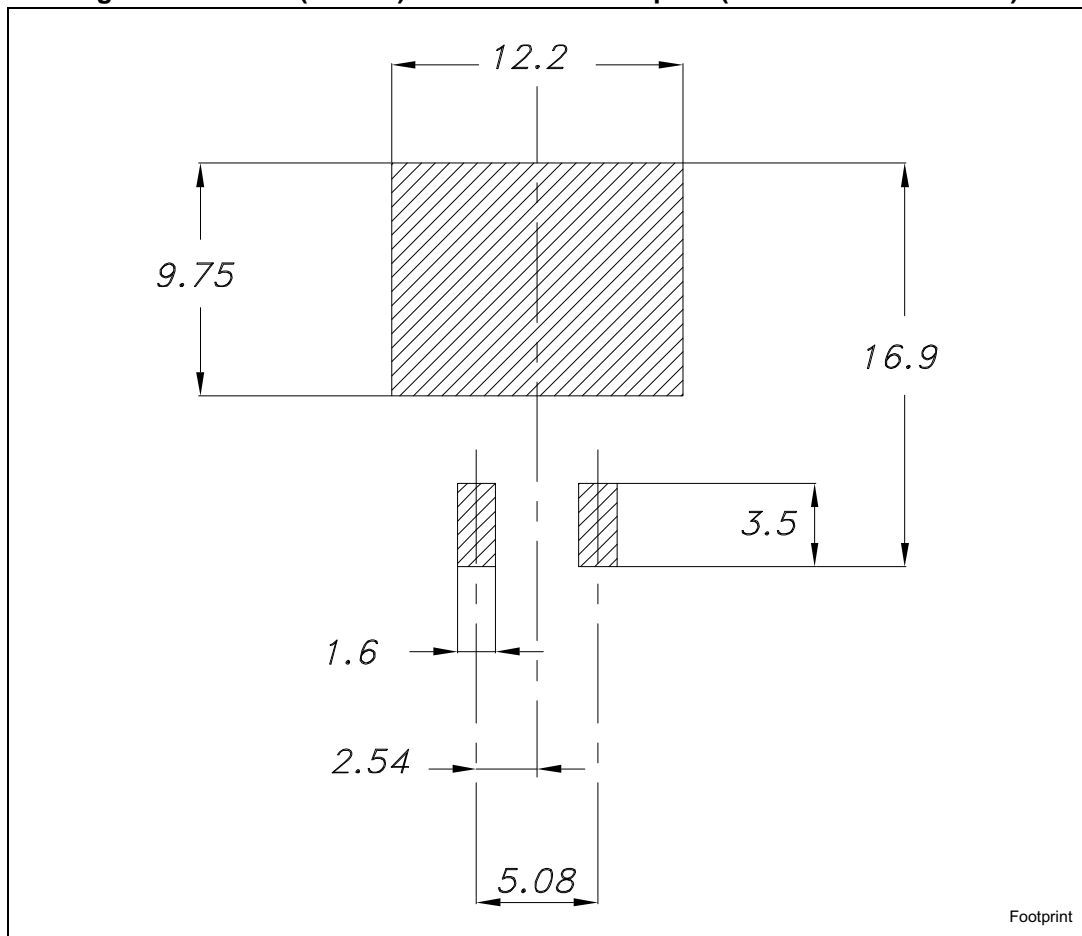

Table 9. D²PAK (TO-263) type A mechanical data

Dim.	mm		
	Min.	Typ.	Max.
A	4.40		4.60
A1	0.03		0.23
b	0.70		0.93
b2	1.14		1.70
c	0.45		0.60
c2	1.23		1.36
D	8.95		9.35
D1	7.50	7.75	8.00
D2	1.10	1.30	1.50
E	10.00		10.40
E1	8.50	8.70	8.90
E2	6.85	7.05	7.25
e		2.54	
e1	4.88		5.28
H	15.00		15.85
J1	2.49		2.69
L	2.29		2.79
L1	1.27		1.40
L2	1.30		1.75
R		0.4	
V2	0°		8°

Figure 24. D²PAK (TO-263) recommended footprint (dimensions are in mm)

4.2 TO-220FP package information

Figure 25. TO-220FP package outline

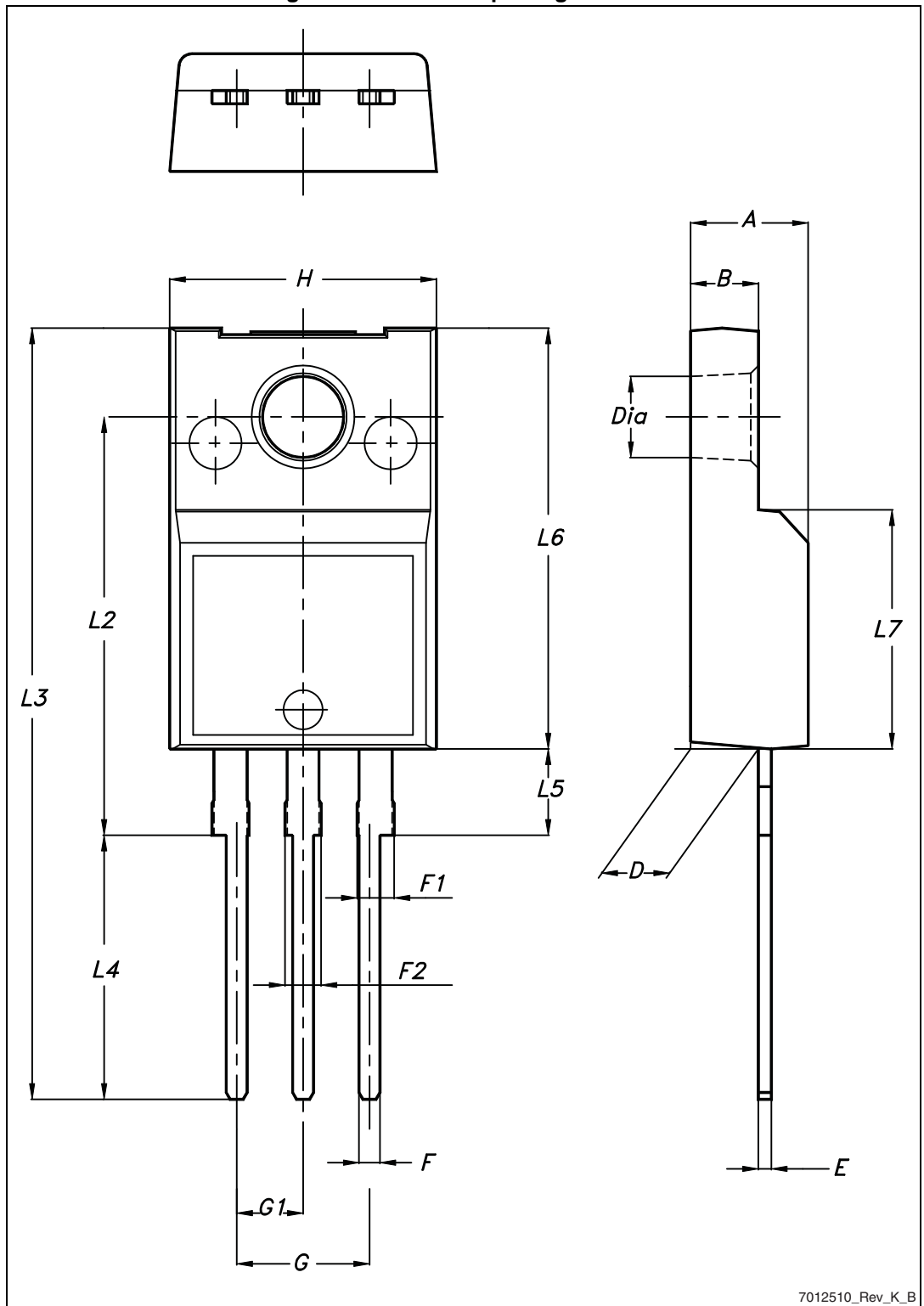

7012510_Rev_K_B

Table 10. TO-220FP package mechanical data

Dim.	mm		
	Min.	Typ.	Max.
A	4.4		4.6
B	2.5		2.7
D	2.5		2.75
E	0.45		0.7
F	0.75		1
F1	1.15		1.70
F2	1.15		1.70
G	4.95		5.2
G1	2.4		2.7
H	10		10.4
L2		16	
L3	28.6		30.6
L4	9.8		10.6
L5	2.9		3.6
L6	15.9		16.4
L7	9		9.3
Dia	3		3.2

4.3 TO-220 package information

Figure 26. TO-220 type A package outline

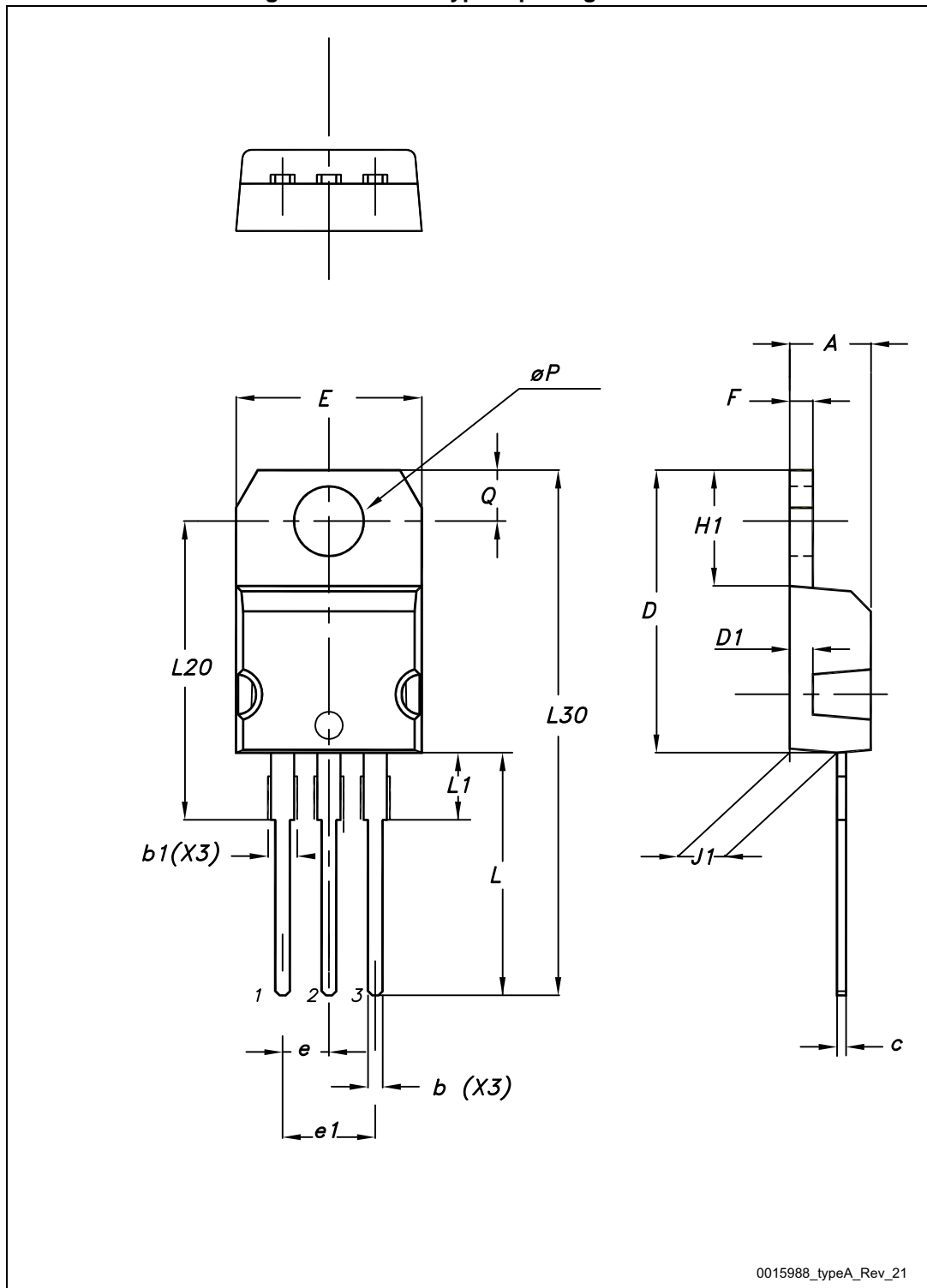

Table 11. TO-220 type A mechanical data

Dim.	mm.		
	Min.	Typ.	Max.
A	4.40		4.60
b	0.61		0.88
b1	1.14		1.55
c	0.48		0.70
D	15.25		15.75
D1		1.27	
E	10.00		10.40
e	2.40		2.70
e1	4.95		5.15
F	1.23		1.32
H1	6.20		6.60
J1	2.40		2.72
L	13.00		14.00
L1	3.50		3.93
L20		16.40	
L30		28.90	
ØP	3.75		3.85
Q	2.65		2.95

4.4 TO-247 package information

Figure 27. TO-247 package outline

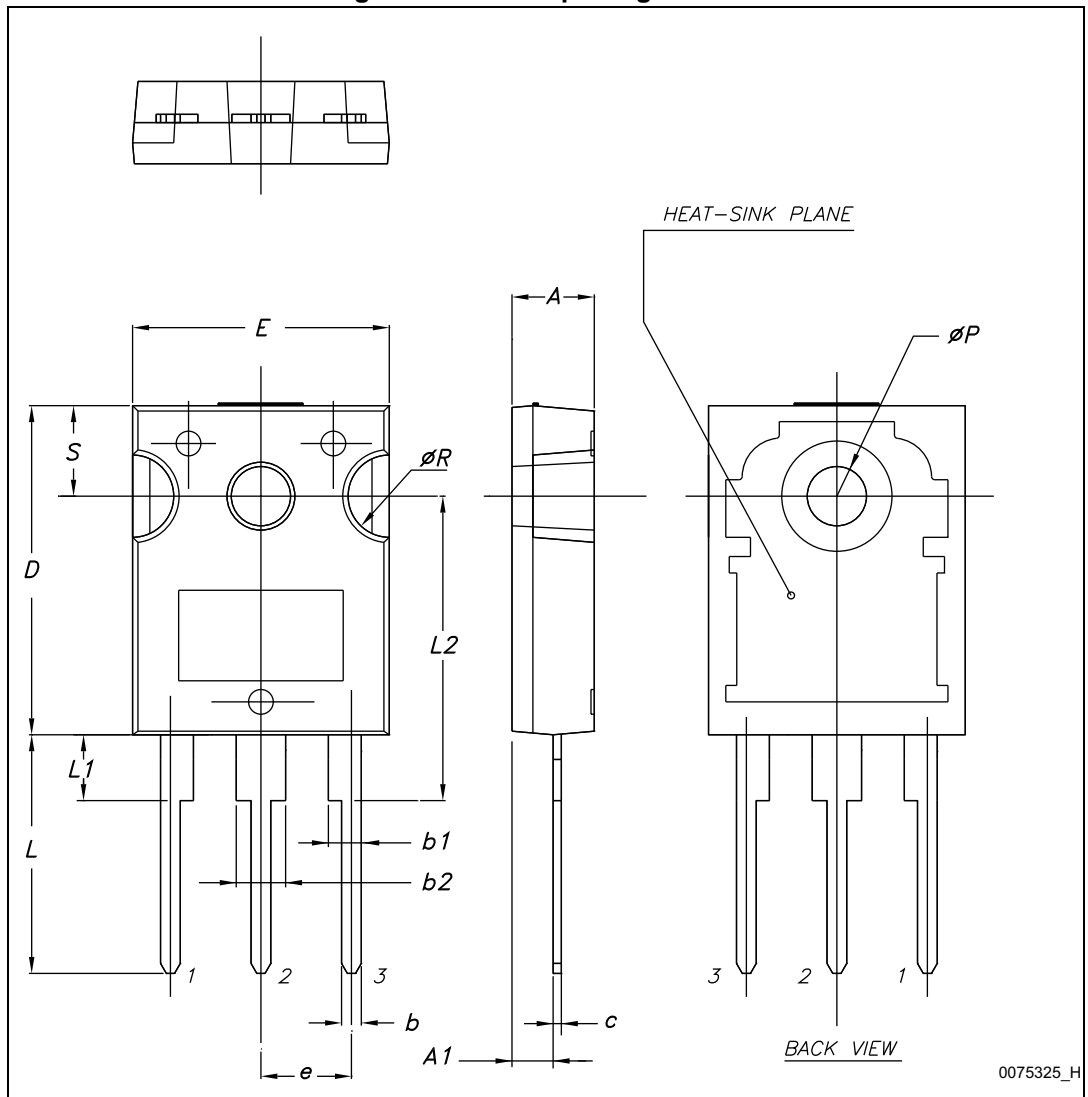

Table 12. TO-247 package mechanical data

Dim.	mm.		
	Min.	Typ.	Max.
A	4.85		5.15
A1	2.20		2.60
b	1.0		1.40
b1	2.0		2.40
b2	3.0		3.40
c	0.40		0.80
D	19.85		20.15
E	15.45		15.75
e	5.30	5.45	5.60
L	14.20		14.80
L1	3.70		4.30
L2		18.50	
ØP	3.55		3.65
ØR	4.50		5.50
S	5.30	5.50	5.70

5 Packing information

Figure 28. D²PAK (TO-263) tape outline

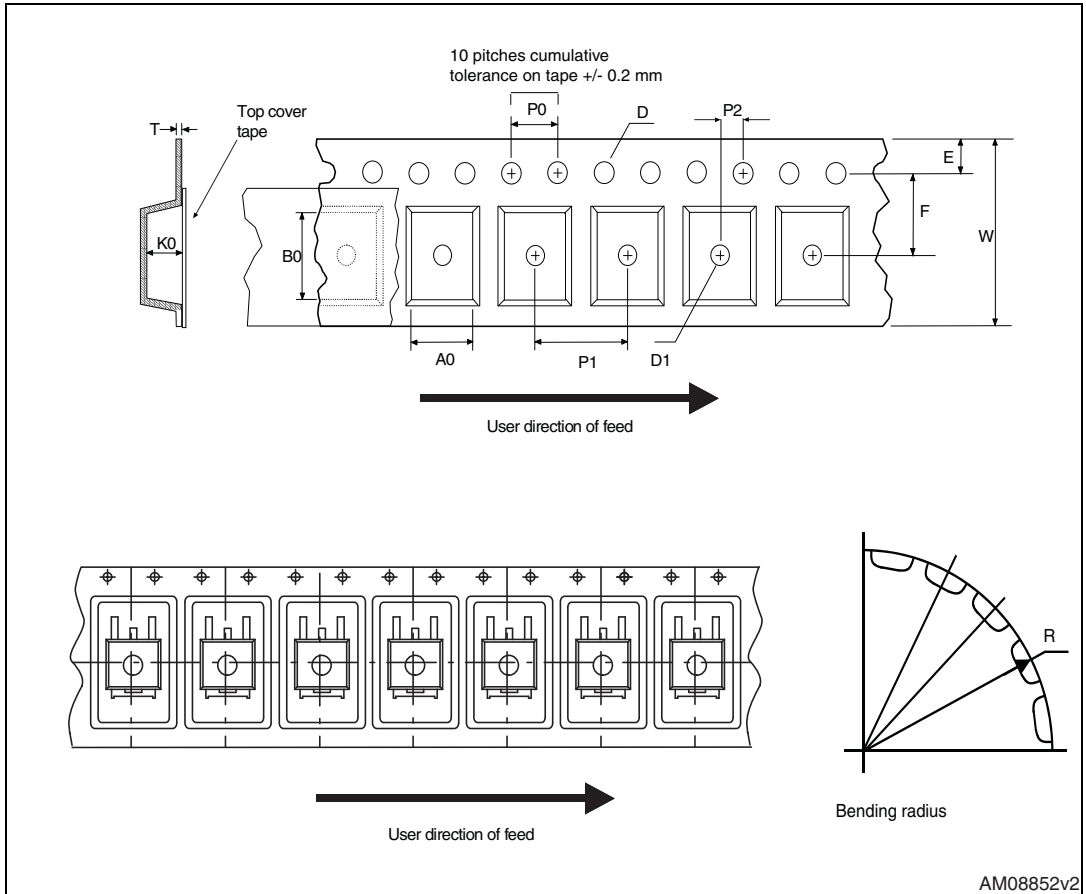

Figure 29. D²PAK (TO-263) reel outline

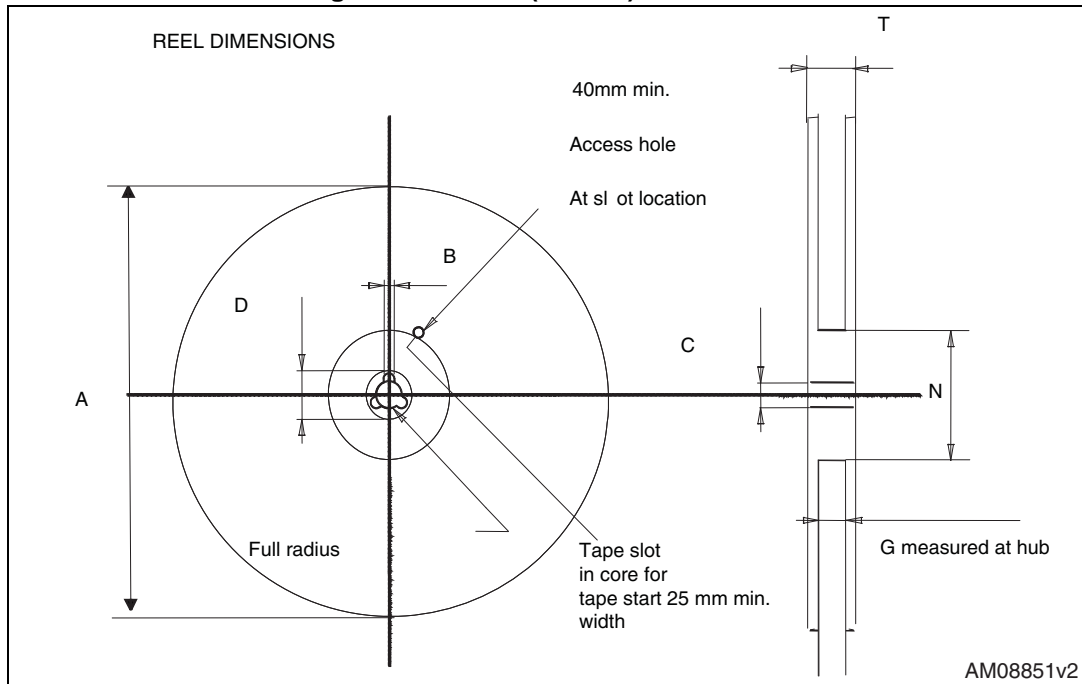

Table 13. D²PAK (TO-263) tape and reel mechanical data

Tape			Reel		
Dim.	mm.		Dim.	mm.	
	Min.	Max.		Min.	Max.
A0	10.5	10.7	A		330
B0	15.7	15.9	B	1.5	
D	1.5	1.6	C	12.8	13.2
D1	1.59	1.61	D	20.2	
E	1.65	1.85	G	24.4	26.4
F	11.4	11.6	N	100	
K0	4.8	5.0	T		30.4
P0	3.9	4.1			
P1	11.9	12.1		Base qty	1000
P2	1.9	2.1		Bulk qty	1000
R	50				
T	0.25	0.35			
W	23.7	24.3			

6 Revision history

Table 14. Document revision history

Date	Revision	Changes
02-Nov-2006	1	Initial release.
05-Jan-2007	2	Complete version.
01-Jul-2008	3	Modified: <i>Table 2: Absolute maximum ratings</i> . Inserted new packages, mechanical data: TO-220FP, TO-247.
13-Oct-2008	4	V_{ISO} inserted in <i>Table 2</i> for TO-220FP.
15-May-2009	5	Updated I_{CP} value.
19-May-2009	6	Updated: mechanical data for TO-220FP.
24-Nov-2010	7	Inserted new order code STGWA19NC60HD in TO-247 long leads package.
14-Dec-2010	8	Updated <i>Table 4: Static</i> .
02-Sep-2011	9	Removed order code STGWA19NC60HD in TO-247 long leads package.
06-Sep-2016	10	Added Section 5.2: TO-247 package information . Minor text changes.