

Figure 1: Internal schematic diagram

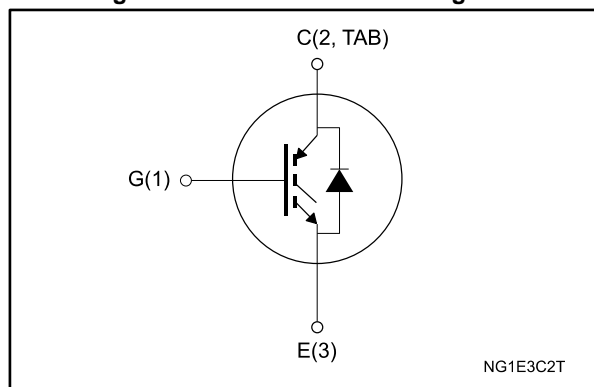

Table 1: Device summary

Order code	Marking	Package	Packing
STGB19NC60KDT4	GB19NC60KD	D <sup>2</sup> PAK	Tape and reel
STGF19NC60KD	GF19NC60KD	TO-220FP	Tube
STGP19NC60KD	GP19NC60KD	TO-220	

### Features

- Low on voltage drop ( $V_{CE(sat)}$ )
- Low  $C_{RES} / C_{IES}$  ratio (no cross-conduction susceptibility)
- Short-circuit withstand time 10  $\mu$ s
- IGBT co-packaged with ultrafast free-wheeling diode

### Applications

- High frequency inverters
- Motor drives

### Description

These devices are very fast IGBTs developed using advanced PowerMESH™ technology. This process guarantees an excellent trade-off between switching performance and low on-state behavior.

**Contents**

**1 Electrical ratings ..... 3**

**2 Electrical characteristics ..... 4**

    2.1 Electrical characteristics (curves) ..... 7

**3 Test circuits ..... 10**

**4 Package information ..... 11**

    4.1 D<sup>2</sup>PAK (TO-263) type A package information ..... 11

    4.2 D<sup>2</sup>PAK (TO-263) type B package information ..... 14

    4.3 D<sup>2</sup>PAK type A packing information ..... 17

    4.4 D<sup>2</sup>PAK type B packing information ..... 19

    4.5 TO-220FP package information ..... 21

    4.6 TO-220 type A package information ..... 23

**5 Revision history ..... 25**



# 1 Electrical ratings

Table 2: Absolute maximum ratings

Symbol	Parameter	Value		Unit
		D <sup>2</sup> PAK, TO-220	TO-220FP	
V <sub>CEs</sub>	Collector-emitter voltage (V <sub>GE</sub> = 0 V)	600		V
I <sub>C</sub> <sup>(1)</sup>	Continuous collector current at T <sub>C</sub> = 25 °C	35	16	A
	Continuous collector current at T <sub>C</sub> = 100 °C	20	10	A
I <sub>CL</sub> <sup>(2)</sup>	Turn-off latching current	75		A
I <sub>CP</sub> <sup>(3)</sup>	Pulsed collector current	75		A
V <sub>GE</sub>	Gate-emitter voltage	±20		V
I <sub>F</sub>	Diode RMS forward current at T <sub>C</sub> = 25 °C	20		A
I <sub>FSM</sub>	Surge non repetitive forward current t <sub>p</sub> = 10 ms sinusoidal	50		A
P <sub>TOT</sub>	Total dissipation at T <sub>C</sub> = 25 °C	125	32	W
V <sub>ISO</sub>	Insulation withstand voltage (RMS) from all three leads to external heat-sink (t = 1 s; T <sub>C</sub> = 25 °C)	2500		V
t <sub>scw</sub>	Short-circuit withstand time V <sub>CE</sub> = 300 V, T <sub>J</sub> = 125 °C, R <sub>G</sub> = 10 Ω, V <sub>GE</sub> = 12 V	10		µs
T <sub>stg</sub>	Storage temperature range	- 55 to 150		°C
T <sub>J</sub>	Operating junction temperature range			

**Notes:**

<sup>(1)</sup>Calculated according to the iterative formula:

$$I_C(T_C) = \frac{T_{J(max)} - T_C}{R_{thj-c} \times V_{CE(sat)(max)}(T_{J(max)}, I_C(T_C))}$$

<sup>(2)</sup>V<sub>clamp</sub> = 80 % V<sub>CEs</sub>, V<sub>GE</sub> = 15 V, R<sub>G</sub> = 10 Ω, T<sub>J</sub> = 150 °C.

<sup>(3)</sup>Pulse width limited by maximum junction temperature.

Table 3: Thermal data

Symbol	Parameter	Value		Unit
		D <sup>2</sup> PAK, TO-220	TO-220FP	
R <sub>thj-case</sub>	Thermal resistance junction-case IGBT	1	3.9	°C/W
R <sub>thj-case</sub>	Thermal resistance junction-case diode	3	5.6	
R <sub>thj-amb</sub>	Thermal resistance junction-ambient	62.5		

## 2 Electrical characteristics

$T_C = 25\text{ °C}$  unless otherwise specified

**Table 4: Static characteristics**

Symbol	Parameter	Test conditions	Min.	Typ.	Max.	Unit
$V_{(BR)CES}$	Collector-emitter breakdown voltage	$I_C = 1\text{ mA}$ , $V_{GE} = 0\text{ V}$	600			V
$V_{CE(sat)}$	Collector-emitter saturation voltage	$V_{GE} = 15\text{ V}$ , $I_C = 12\text{ A}$		2.0	2.75	V
		$V_{GE} = 15\text{ V}$ , $I_C = 12\text{ A}$ , $T_C = 125\text{ °C}$		1.65		
$V_{GE(th)}$	Gate threshold voltage	$V_{CE} = V_{GE}$ , $I_C = 250\text{ }\mu\text{A}$	4.5		6.5	V
$I_{CES}$	Collector cut-off current	$V_{CE} = 600\text{ V}$ , $V_{GE} = 0\text{ V}$			150	$\mu\text{A}$
		$V_{CE} = 600\text{ V}$ , $V_{GE} = 0\text{ V}$ , $T_C = 125\text{ °C}$ <sup>(1)</sup>			1	mA
$I_{GES}$	Gate-emitter leakage current	$V_{CE} = 0\text{ V}$ , $V_{GE} = \pm 20\text{ V}$			$\pm 100$	nA

**Notes:**

<sup>(1)</sup>Defined by design, not subject to production test.

**Table 5: Dynamic characteristics**

Symbol	Parameter	Test conditions	Min.	Typ.	Max.	Unit
$C_{ies}$	Input capacitance	$V_{CE} = 25\text{ V}$ , $f = 1\text{ MHz}$ , $V_{GE} = 0\text{ V}$	-	1170	-	pF
$C_{oes}$	Output capacitance		-	127	-	
$C_{res}$	Reverse transfer capacitance		-	28	-	
$Q_g$	Total gate charge	$V_{CE} = 480\text{ V}$ , $I_C = 12\text{ A}$ , $V_{GE} = 0\text{ to }15\text{ V}$ (see <a href="#">Figure 20: "Gate charge test circuit"</a> )	-	55	-	nC
$Q_{ge}$	Gate-emitter charge		-	11	-	
$Q_{gc}$	Gate-collector charge		-	26	-	

Table 6: Switching on/off (inductive load)

Symbol	Parameter	Test conditions	Min.	Typ.	Max.	Unit
$t_{d(on)}$	Turn-on delay time	$V_{CC} = 480\text{ V}$ , $I_C = 12\text{ A}$ , $R_G = 10\ \Omega$ , $V_{GE} = 15\text{ V}$ (see <a href="#">Figure 19</a> : "Test circuit for inductive load switching" and <a href="#">Figure 21</a> : "Switching waveform")	-	30	-	ns
$t_r$	Current rise time		-	8	-	ns
$(di/dt)_{on}$	Turn-on current slope		-	1450	-	A/ $\mu$ s
$t_{d(on)}$	Turn-on delay time	$V_{CC} = 480\text{ V}$ , $I_C = 12\text{ A}$ , $R_G = 10\ \Omega$ , $V_{GE} = 15\text{ V}$ , $T_C = 125\text{ }^\circ\text{C}$ (see <a href="#">Figure 19</a> : "Test circuit for inductive load switching" and <a href="#">Figure 21</a> : "Switching waveform")	-	30	-	ns
$t_r$	Current rise time		-	8	-	ns
$(di/dt)_{on}$	Turn-on current slope		-	1380	-	A/ $\mu$ s
$t_{r(Voff)}$	Off voltage rise time	$V_{CC} = 480\text{ V}$ , $I_C = 12\text{ A}$ , $R_G = 10\ \Omega$ , $V_{GE} = 15\text{ V}$ (see <a href="#">Figure 19</a> : "Test circuit for inductive load switching" and <a href="#">Figure 21</a> : "Switching waveform")	-	35	-	ns
$t_{d(off)}$	Turn-off delay time		-	105	-	ns
$t_f$	Current fall time		-	85	-	ns
$t_{r(Voff)}$	Off voltage rise time	$V_{CC} = 480\text{ V}$ , $I_C = 12\text{ A}$ , $R_G = 10\ \Omega$ , $V_{GE} = 15\text{ V}$ , $T_C = 125\text{ }^\circ\text{C}$ (see <a href="#">Figure 19</a> : "Test circuit for inductive load switching" and <a href="#">Figure 21</a> : "Switching waveform")	-	65	-	ns
$t_{d(off)}$	Turn-off delay time		-	145	-	ns
$t_f$	Current fall time		-	125	-	ns

Table 7: Switching energy (inductive load)

Symbol	Parameter	Test conditions	Min.	Typ.	Max.	Unit
$E_{on(1)}$	Turn-on switching energy	$V_{CC} = 480\text{ V}$ , $I_C = 12\text{ A}$ , $R_G = 10\ \Omega$ , $V_{GE} = 15\text{ V}$ (see <a href="#">Figure 19</a> : "Test circuit for inductive load switching")	-	165	-	$\mu$ J
$E_{off(2)}$	Turn-off switching energy		-	255	-	$\mu$ J
$E_{ts}$	Total switching energy		-	420	-	$\mu$ J
$E_{on(1)}$	Turn-on switching energy	$V_{CC} = 480\text{ V}$ , $I_C = 12\text{ A}$ , $R_G = 10\ \Omega$ , $V_{GE} = 15\text{ V}$ , $T_C = 125\text{ }^\circ\text{C}$ (see <a href="#">Figure 19</a> : "Test circuit for inductive load switching")	-	250	-	$\mu$ J
$E_{off(2)}$	Turn-off switching energy		-	445	-	$\mu$ J
$E_{ts}$	Total switching energy		-	695	-	$\mu$ J

**Notes:**

- (1) Including the reverse recovery of the diode.
- (2) Including the tail of the collector current.

Table 8: Collector-emitter diode

Symbol	Parameter	Test conditions	Min.	Typ.	Max.	Unit
V <sub>F</sub>	Forward on-voltage	I <sub>F</sub> =12 A	-	1.9	-	V
		I <sub>F</sub> =12 A, T <sub>C</sub> =125 °C	-	1.6	-	V
t <sub>rr</sub>	Reverse recovery time	I <sub>F</sub> =12 A, V <sub>R</sub> =40 V, di/dt=100 A/μs (see <a href="#">Figure 22: "Diode reverse recovery waveform"</a> )	-	31	-	ns
Q <sub>rr</sub>	Reverse recovery charge		-	30	-	nC
I <sub>rrm</sub>	Reverse recovery current		-	2	-	A
t <sub>rr</sub>	Reverse recovery time	I <sub>F</sub> =12 A, V <sub>R</sub> =40 V, T <sub>C</sub> =125 °C, di/dt=100 A/μs (see <a href="#">Figure 22: "Diode reverse recovery waveform"</a> )	-	50	-	ns
Q <sub>rr</sub>	Reverse recovery charge		-	70	-	nC
I <sub>rrm</sub>	Reverse recovery current		-	4	-	A

## 2.1 Electrical characteristics (curves)

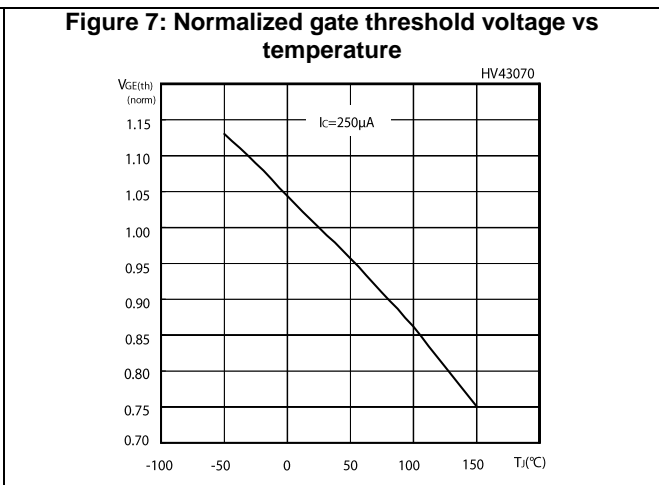
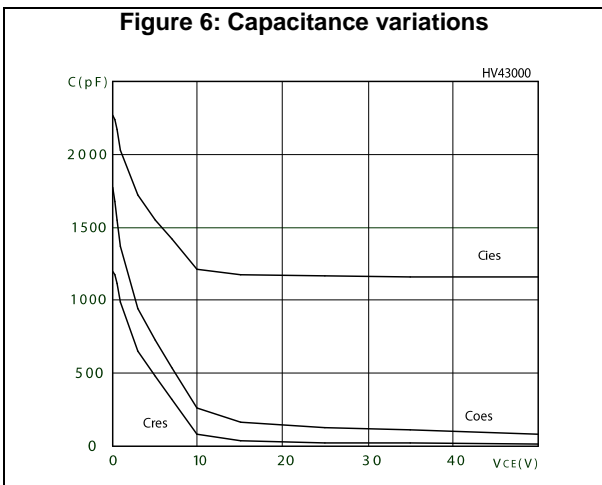
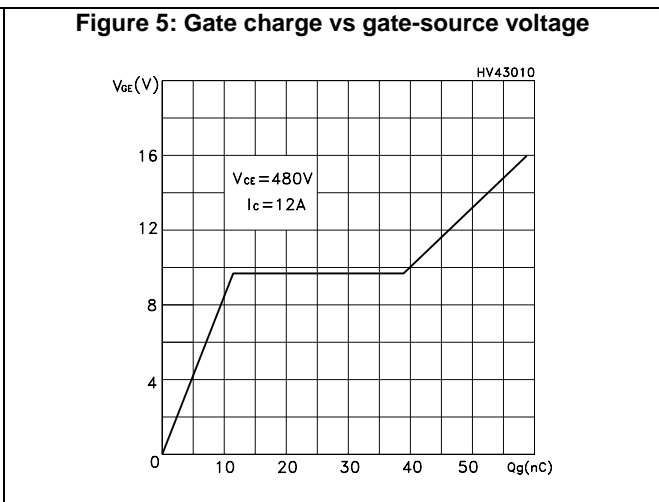
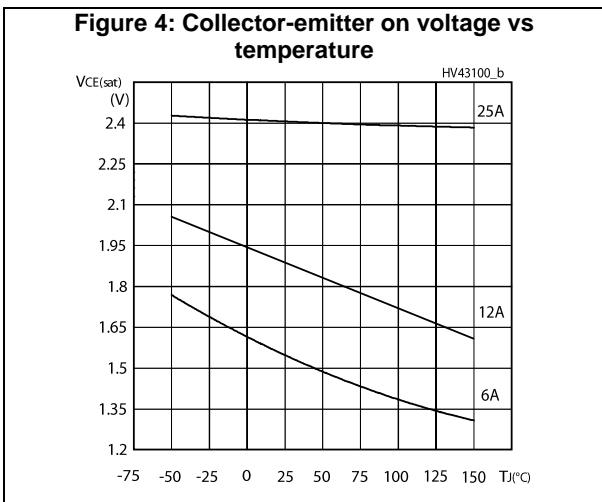
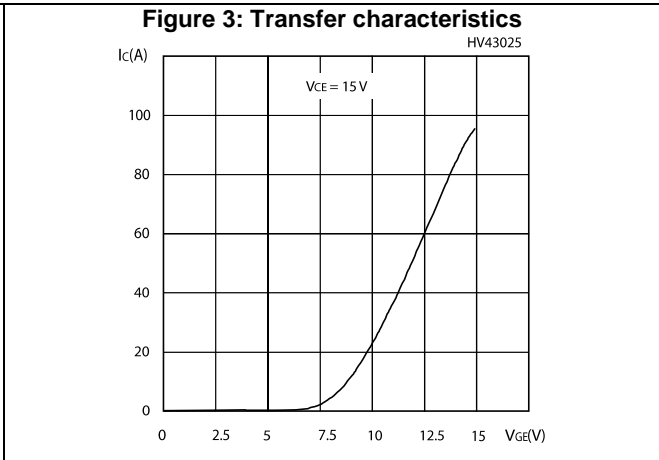
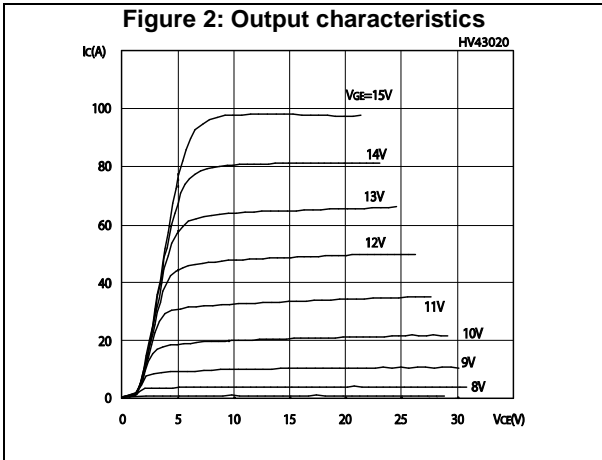

**Figure 8: Collector-emitter on voltage vs collector current**

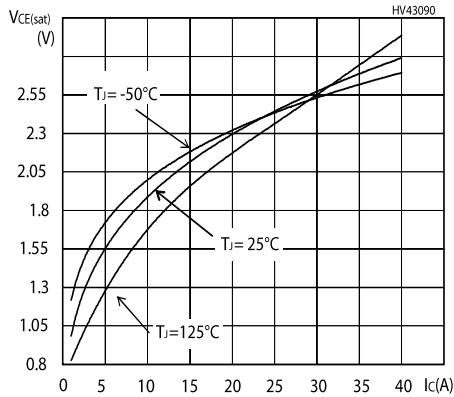

**Figure 9: Normalized breakdown voltage vs temperature**

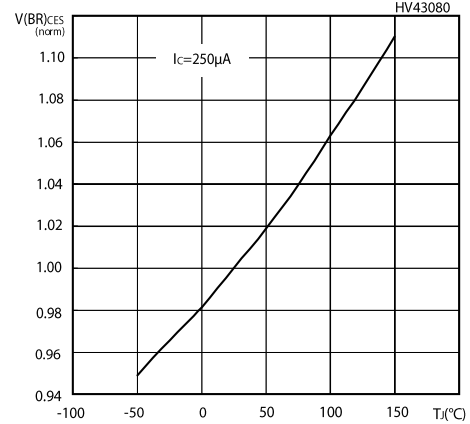

**Figure 10: Switching energy vs temperature**

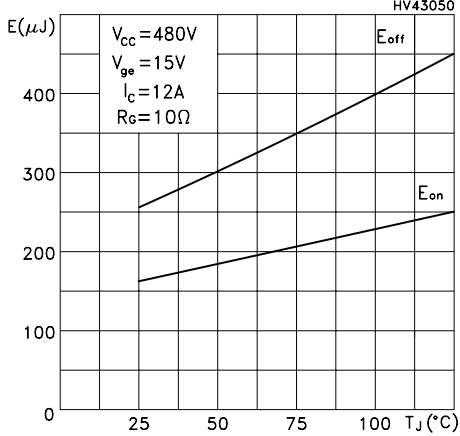

**Figure 11: Switching energy vs. gate resistance**

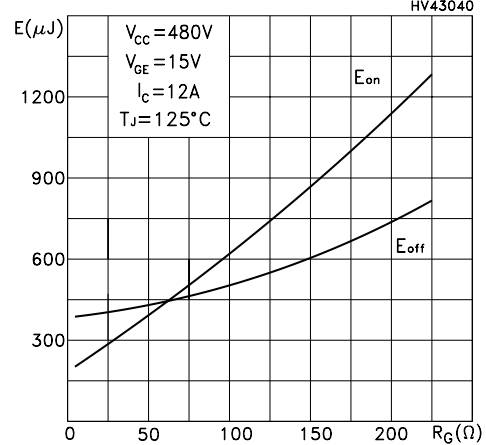

**Figure 12: Switching energy vs collector current**

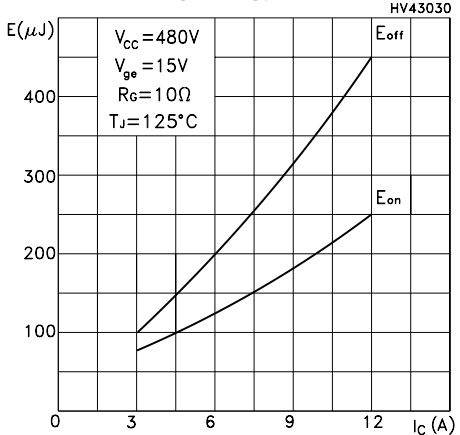

**Figure 13: Turn-off SOA**

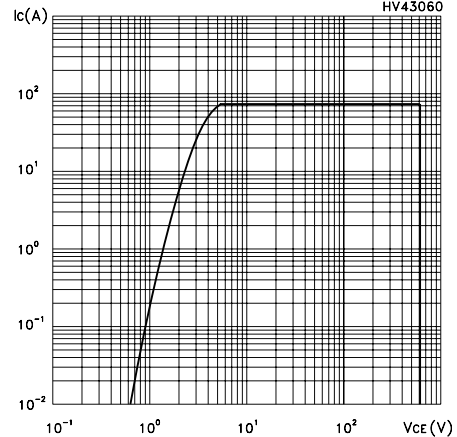



Figure 14: Emitter-collector diode characteristics

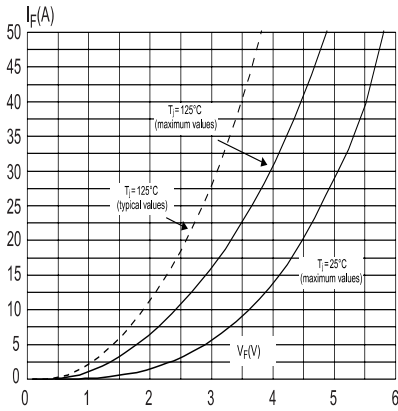

Figure 15: Thermal impedance for TO-220, D<sup>2</sup>PAK

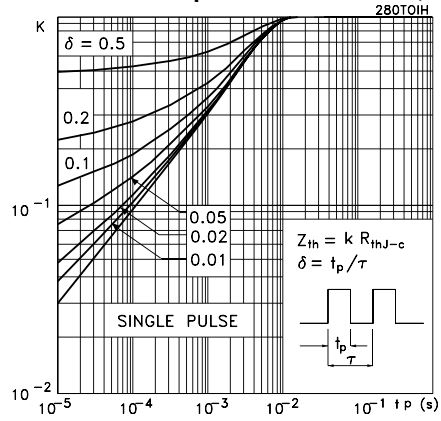

Figure 16: Thermal impedance for TO-220FP

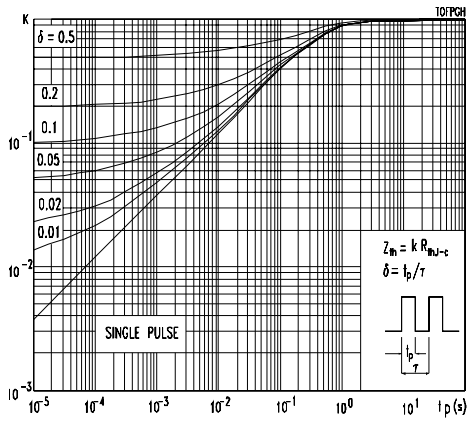

Figure 17: Maximum DC collector current vs T<sub>CASE</sub> for TO-220FP

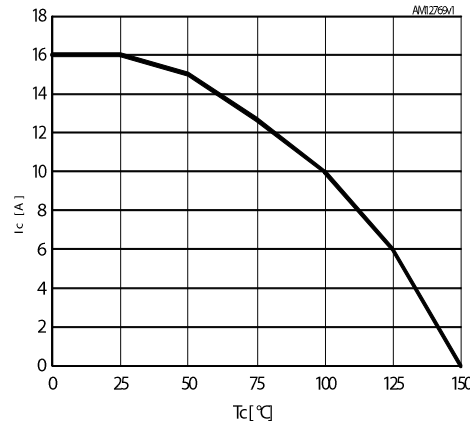
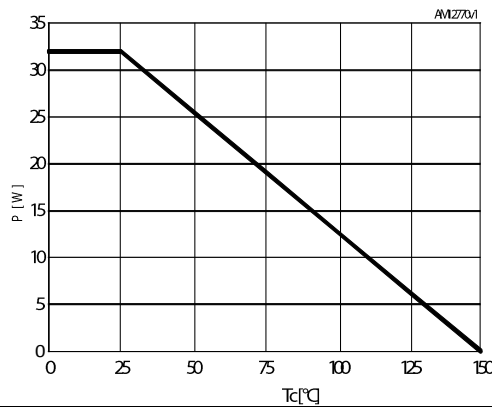
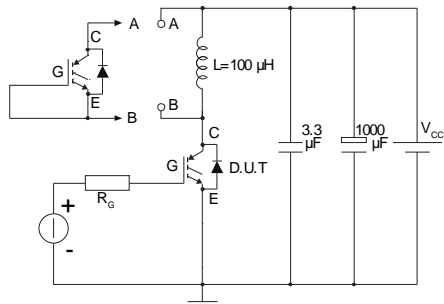

Figure 18: Maximum power dissipation vs T<sub>CASE</sub> for TO-220FP



### 3 Test circuits

**Figure 19: Test circuit for inductive load switching**



AM01504v1

**Figure 20: Gate charge test circuit**

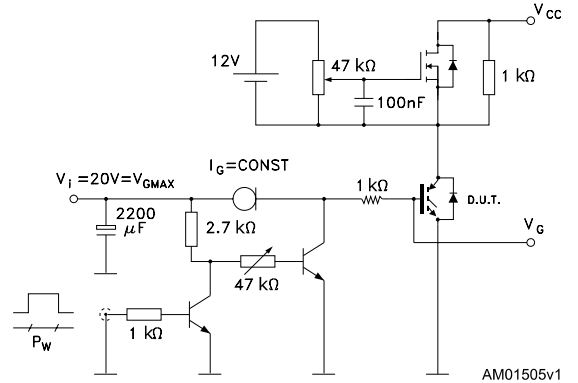

AM01505v1

**Figure 21: Switching waveform**

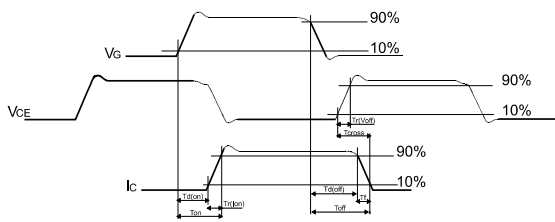

AM01506v1

**Figure 22: Diode reverse recovery waveform**

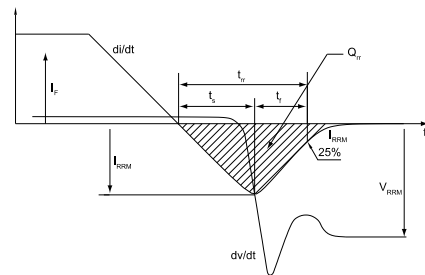

AM01507v1

## 4 Package information

In order to meet environmental requirements, ST offers these devices in different grades of ECOPACK® packages, depending on their level of environmental compliance. ECOPACK® specifications, grade definitions and product status are available at: [www.st.com](http://www.st.com). ECOPACK® is an ST trademark.

### 4.1 D<sup>2</sup>PAK (TO-263) type A package information

Figure 23: D<sup>2</sup>PAK (TO-263) type A package outline

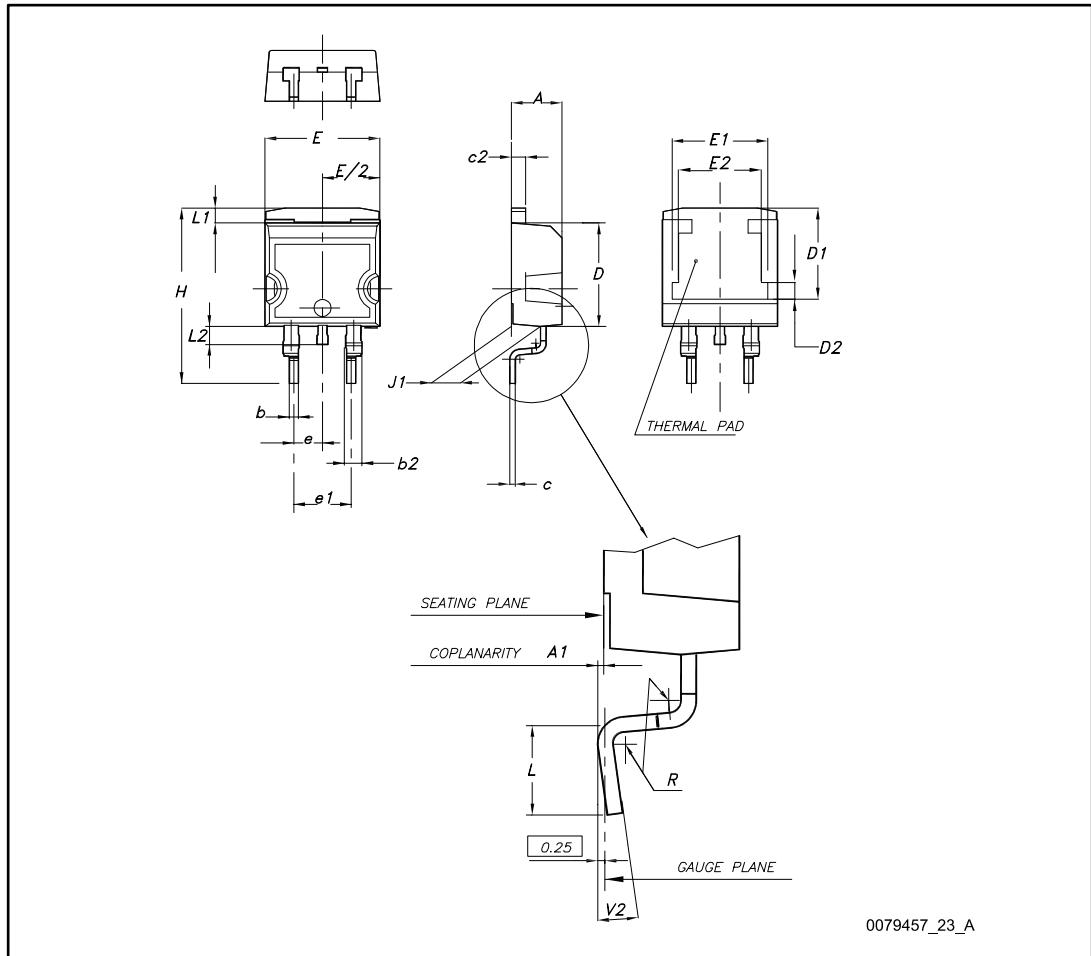
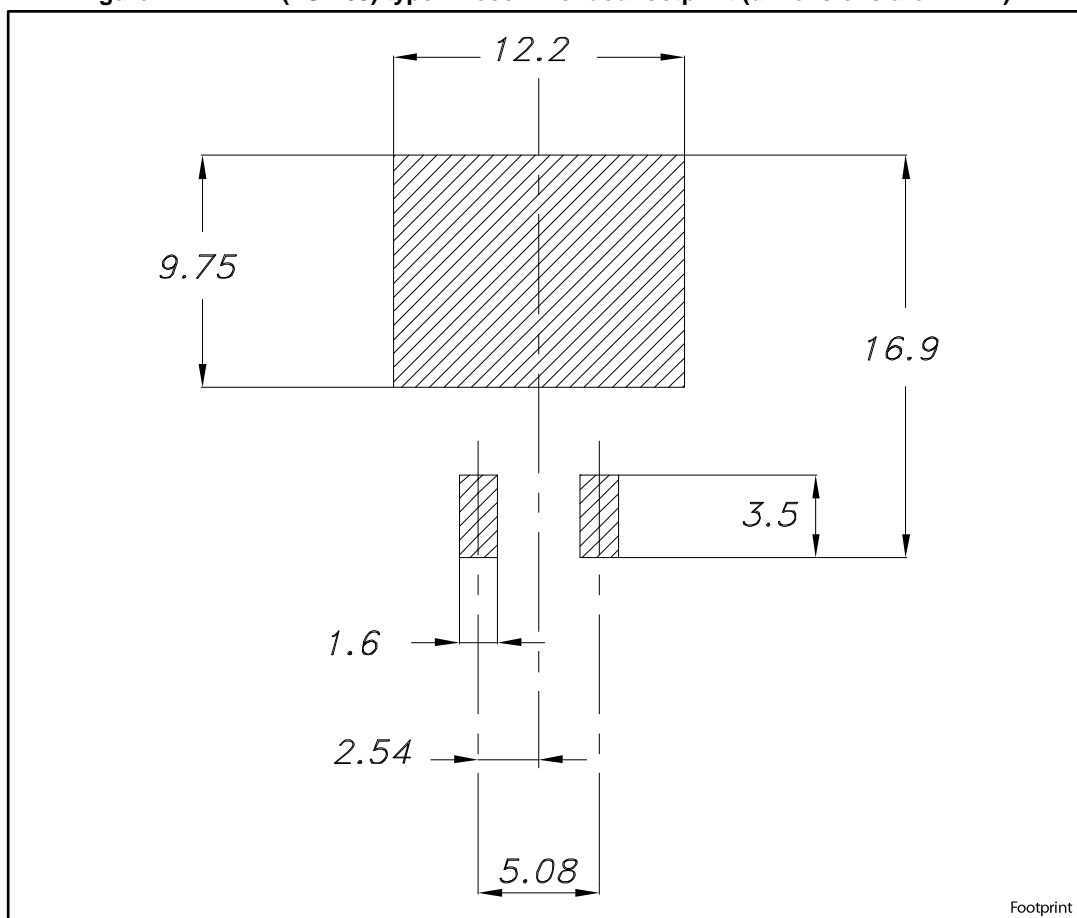

Table 9: D<sup>2</sup>PAK (TO-263) type A package mechanical data

Dim.	mm		
	Min.	Typ.	Max.
A	4.40		4.60
A1	0.03		0.23
b	0.70		0.93
b2	1.14		1.70
c	0.45		0.60
c2	1.23		1.36
D	8.95		9.35
D1	7.50	7.75	8.00
D2	1.10	1.30	1.50
E	10.00		10.40
E1	8.50	8.70	8.90
E2	6.85	7.05	7.25
e		2.54	
e1	4.88		5.28
H	15.00		15.85
J1	2.49		2.69
L	2.29		2.79
L1	1.27		1.40
L2	1.30		1.75
R		0.40	
V2	0°		8°

Figure 24: D<sup>2</sup>PAK (TO-263) type A recommended footprint (dimensions are in mm)



### 4.2 D<sup>2</sup>PAK (TO-263) type B package information

Figure 25: D<sup>2</sup>PAK (TO-263) type B package outline

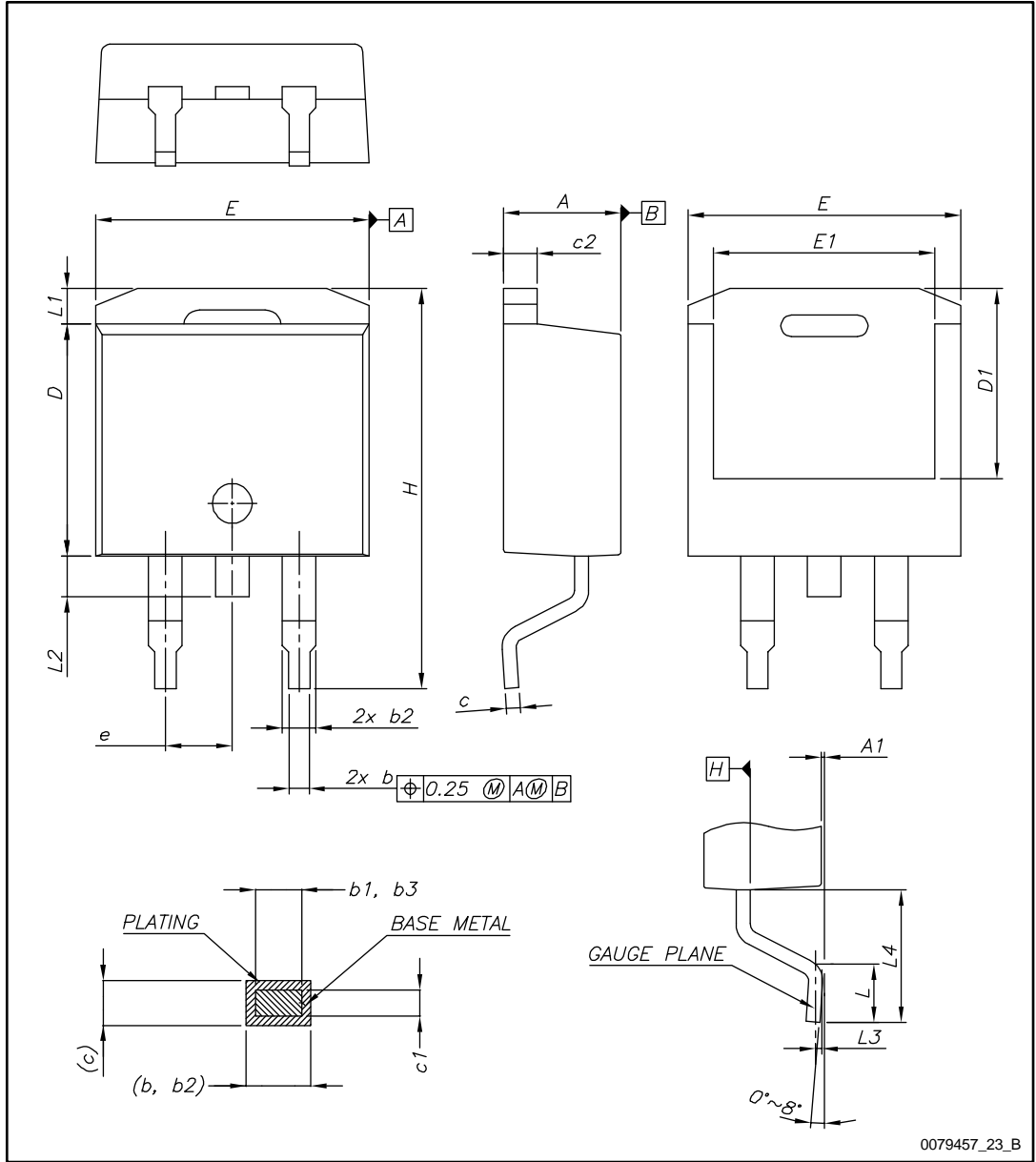
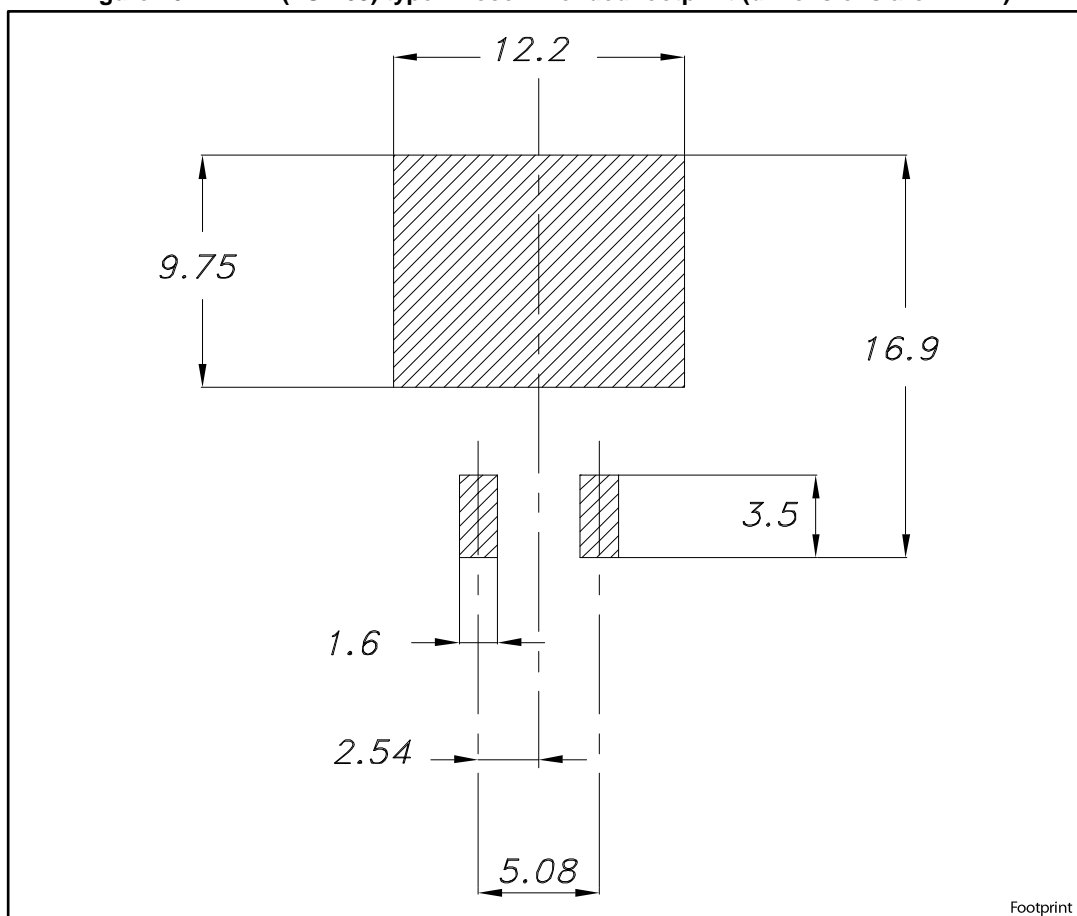

Table 10: D<sup>2</sup>PAK (TO-263) type B mechanical data

Dim.	mm		
	Min.	Typ.	Max.
A	4.36		4.56
A1	0		0.25
b	0.70		0.90
b1	0.51		0.89
b2	1.17		1.37
b3	1.36		1.46
c	0.38		0.694
c1	0.38		0.534
c2	1.19		1.34
D	8.60		9.00
D1	6.90		7.50
E	10.15		10.55
E1	8.10		8.70
e	2.54 BSC		
H	15.00		15.60
L	1.90		2.50
L1			1.65
L2			1.78
L3		0.25	
L4	4.78		5.28

Figure 26: D<sup>2</sup>PAK (TO-263) type B recommended footprint (dimensions are in mm)





### 4.3 D<sup>2</sup>PAK type A packing information

Figure 27: D<sup>2</sup>PAK type A tape outline

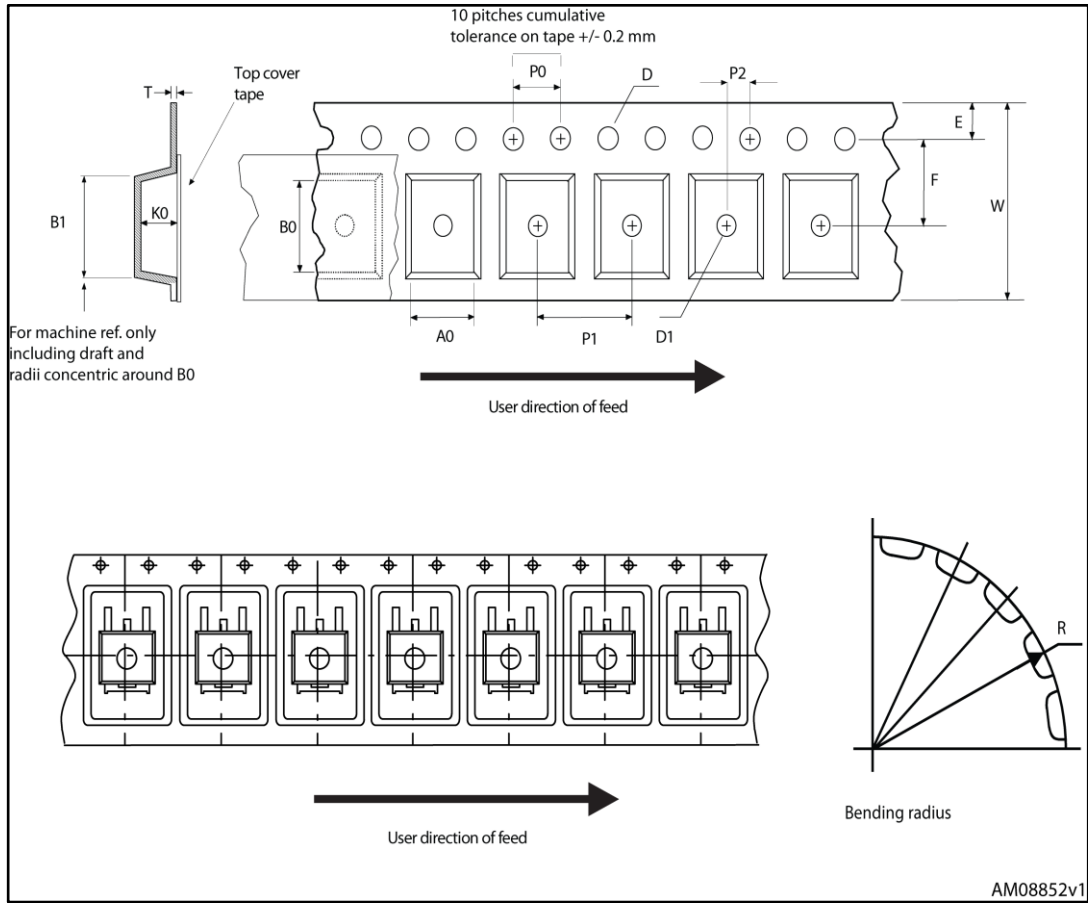

Figure 28: D<sup>2</sup>PAK type A reel outline

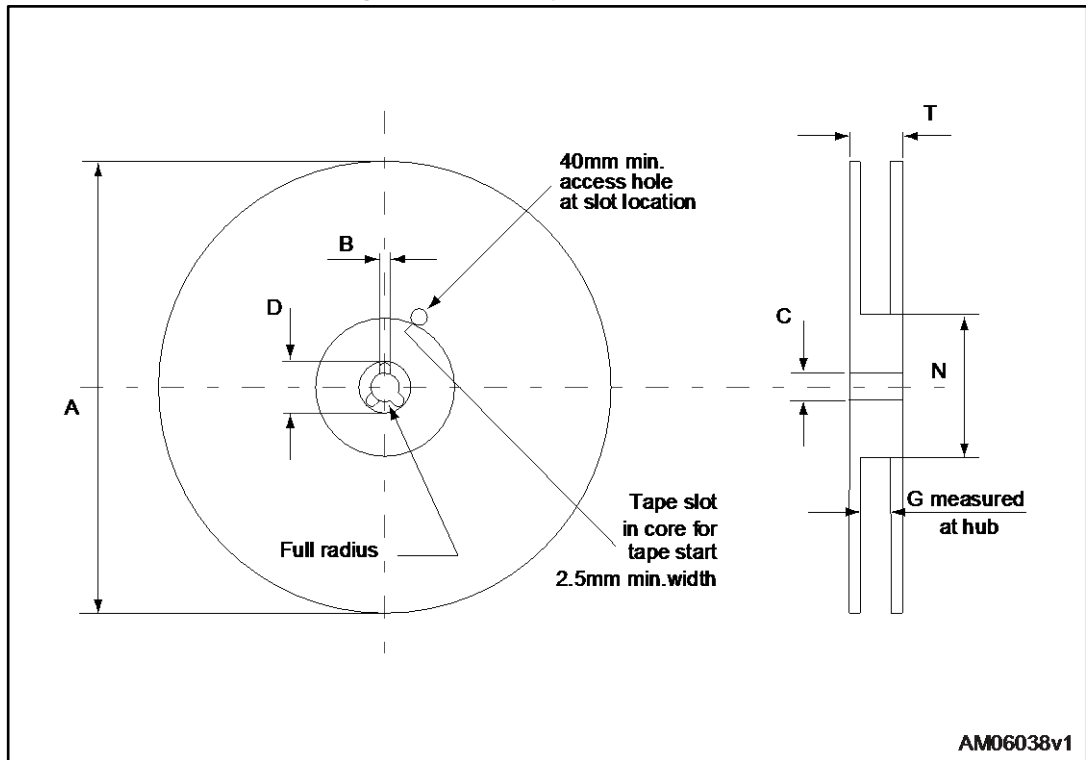

Table 11: D<sup>2</sup>PAK type A tape and reel mechanical data

Tape			Reel		
Dim.	mm		Dim.	mm	
	Min.	Max.		Min.	Max.
A0	10.5	10.7	A		330
B0	15.7	15.9	B	1.5	
D	1.5	1.6	C	12.8	13.2
D1	1.59	1.61	D	20.2	
E	1.65	1.85	G	24.4	26.4
F	11.4	11.6	N	100	
K0	4.8	5.0	T		30.4
P0	3.9	4.1			
P1	11.9	12.1	Base quantity		1000
P2	1.9	2.1	Bulk quantity		1000
R	50				
T	0.25	0.35			
W	23.7	24.3			

### 4.4 D<sup>2</sup>PAK type B packing information

Figure 29: D<sup>2</sup>PAK type B tape outline

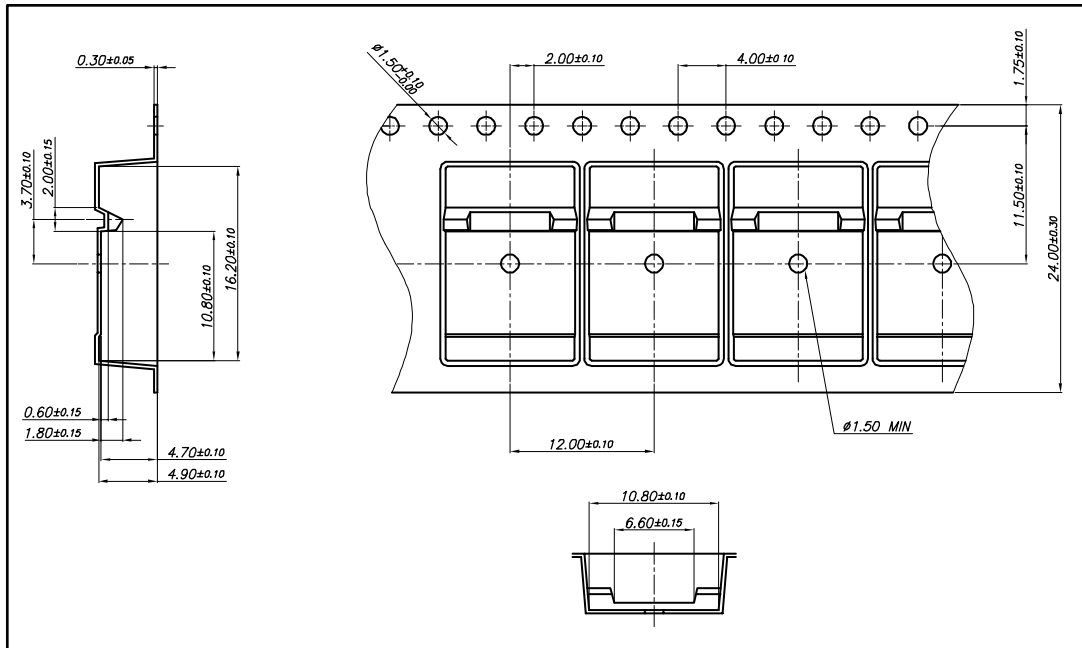

Figure 30: D<sup>2</sup>PAK type B reel outline

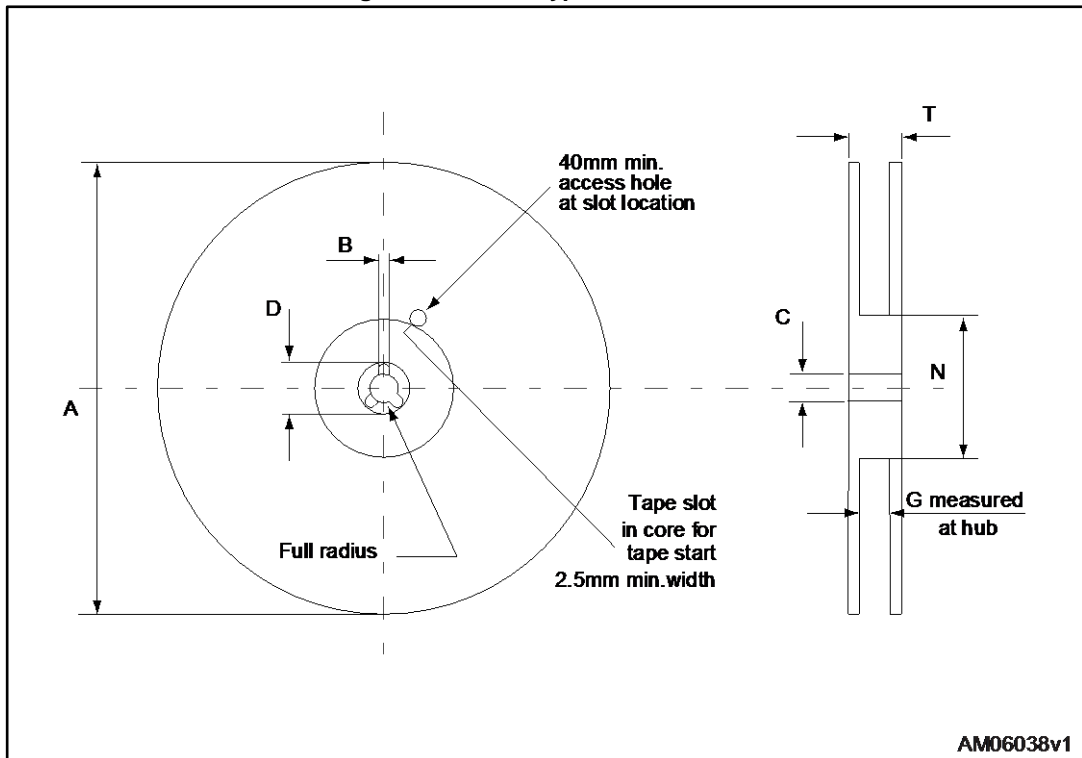
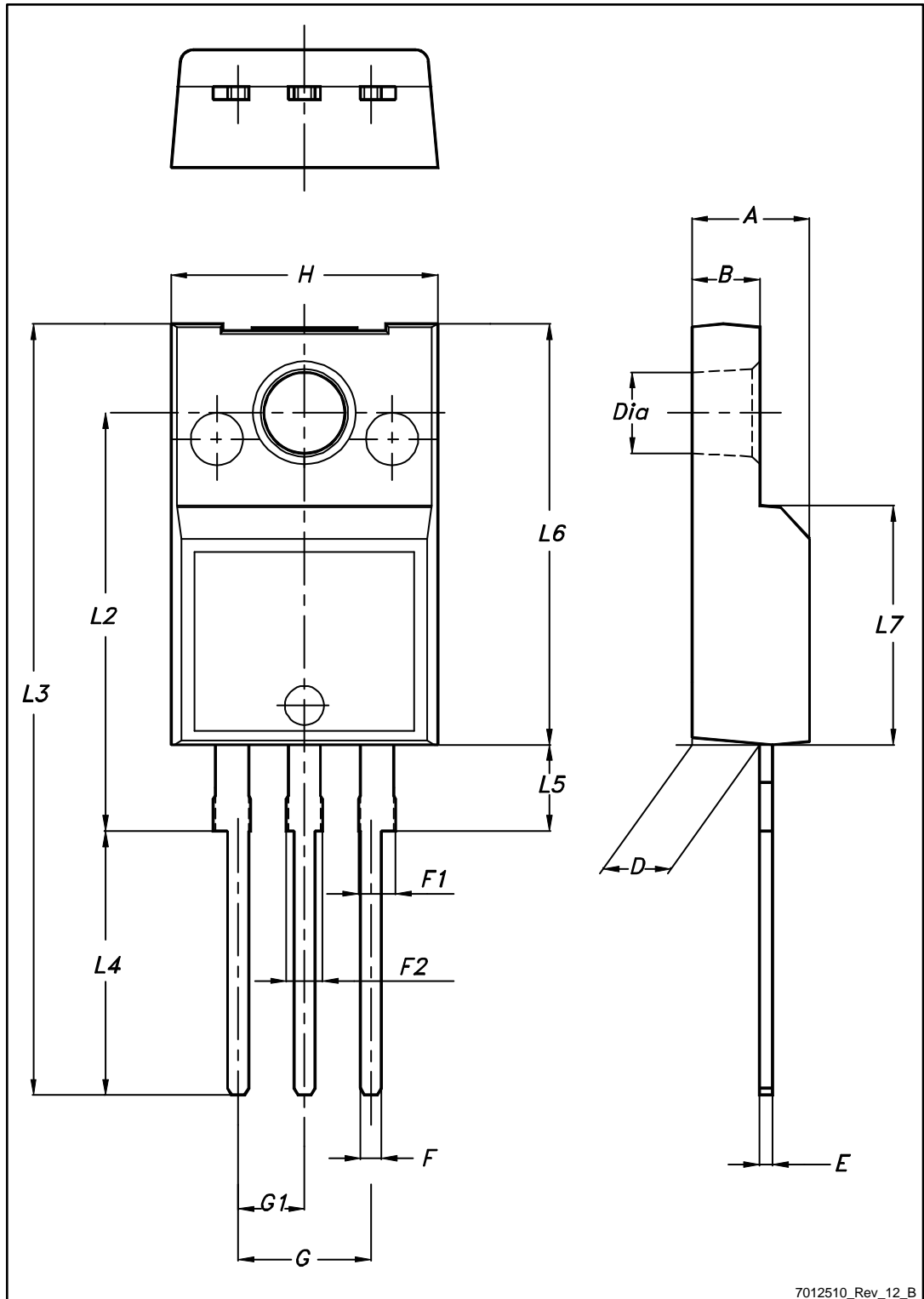

Table 12: D<sup>2</sup>PAK type B reel mechanical data

Dim.	mm	
	Min.	Max.
A		330
B	1.5	
C	12.8	13.2
D	20.2	
G	24.4	26.4
N	100	
T		30.4

### 4.5 TO-220FP package information

Figure 31: TO-220FP package outline



7012510\_Rev\_12\_B

Table 13: TO-220FP package mechanical data

Dim.	mm		
	Min.	Typ.	Max.
A	4.4		4.6
B	2.5		2.7
D	2.5		2.75
E	0.45		0.7
F	0.75		1
F1	1.15		1.70
F2	1.15		1.70
G	4.95		5.2
G1	2.4		2.7
H	10		10.4
L2		16	
L3	28.6		30.6
L4	9.8		10.6
L5	2.9		3.6
L6	15.9		16.4
L7	9		9.3
Dia	3		3.2

### 4.6 TO-220 type A package information

Figure 32: TO-220 type A package outline

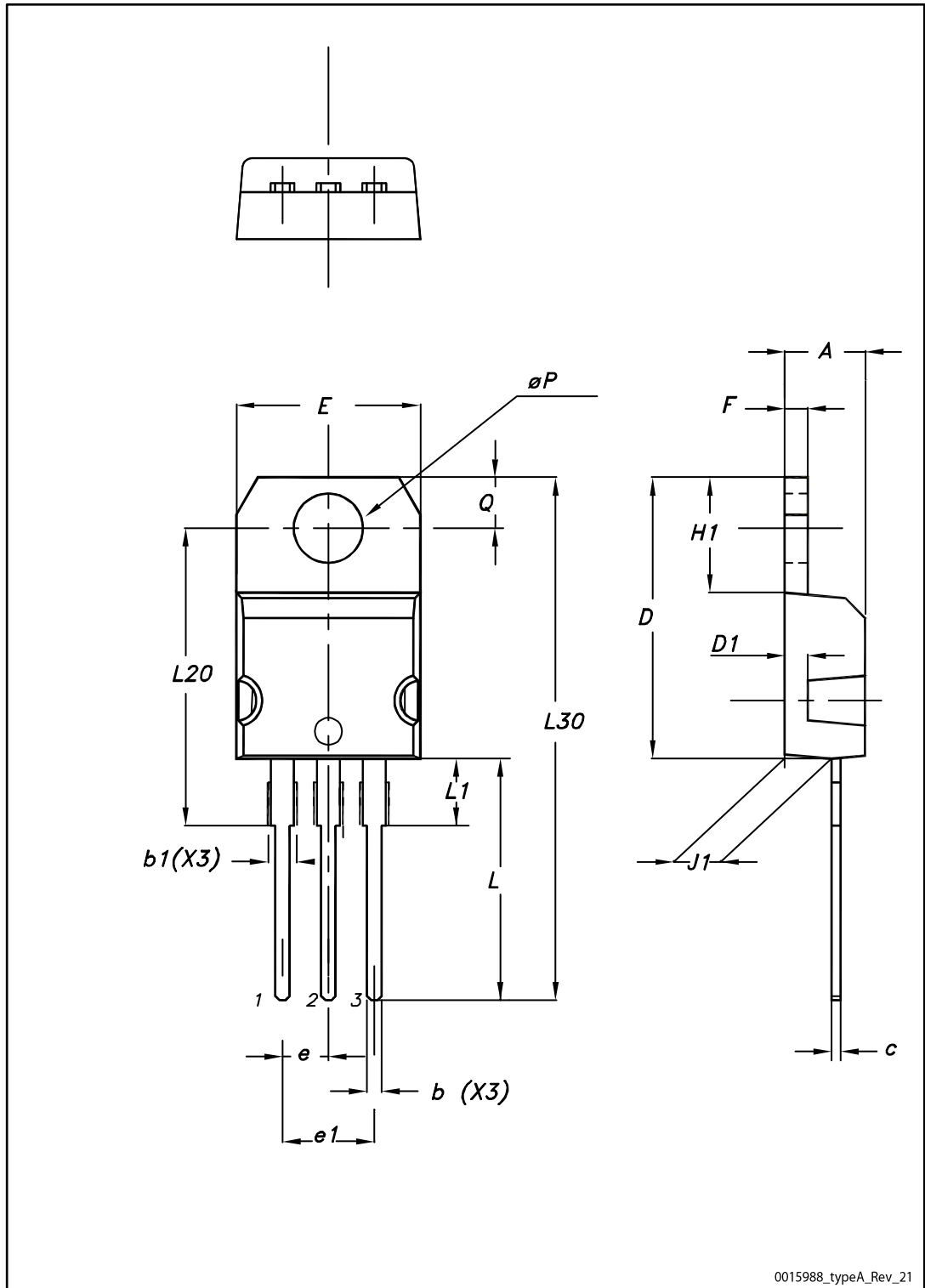

0015988\_typeA\_Rev\_21

Table 14: TO-220 type A package mechanical data

Dim.	mm		
	Min.	Typ.	Max.
A	4.40		4.60
b	0.61		0.88
b1	1.14		1.55
c	0.48		0.70
D	15.25		15.75
D1		1.27	
E	10.00		10.40
e	2.40		2.70
e1	4.95		5.15
F	1.23		1.32
H1	6.20		6.60
J1	2.40		2.72
L	13.00		14.00
L1	3.50		3.93
L20		16.40	
L30		28.90	
øP	3.75		3.85
Q	2.65		2.95



## 5 Revision history

Table 15: Document revision history

Date	Revision	Changes
08-May-2008	1	Initial release
28-May-2008	2	– Value on Table 3: Thermal resistance has been changed. – Inserted Figure 16: Thermal impedance for TO-220, D <sup>2</sup> PAK and Figure 17: Thermal impedance for TO-220FP
31-Jul-2012	3	Added: Figure 18 and Figure 19 on page 8.
17-Jul-2017	4	Modified internal schematic diagram on cover page Modified <i>Table 2: "Absolute maximum ratings"</i> , <i>Table 3: "Thermal data"</i> , and <i>Table 4: "Static characteristics"</i> . Modified <i>Figure 3: "Transfer characteristics"</i> , <i>Figure 4: "Collector-emitter on voltage vs temperature"</i> and <i>Figure 8: "Collector-emitter on voltage vs collector current"</i> . Updated <i>Section 4: "Package information"</i> . Minor text changes.